



© 2012 Mazda Motor of America, Inc.

| | |
|---|--------------------------------|
| Subject: STAINS FOUND ON PAINT DURING PDI | Bulletin No: 09-011/12 |
| | Last Issued: 03/12/2012 |

BULLETIN NOTE

- This bulletin supersedes the previous bulletins 09-015/04 issued 04/26/04 and 05/14/04, 09-004/05 issued 02/18/05 and 09/23/05, 09-036/09 issued 07/17/09, 07/27/09 and 11/12/09. The APPLICABLE MODEL(S)/VINS have been revised.
- Changes are noted below in Red beside the change bar.

APPLICABLE MODEL(S)/VINS

- 2011-2013 MX-5
- 2011 RX-8
- 2011-2013 Mazda2
- 2011-2013 Mazda3
- 2012-2013 Mazda5
- 2011-2013 Mazda6
- 2013 CX-5
- 2011-2012 CX-7
- 2011-2013 CX-9

DESCRIPTION

Some vehicles may experience stains appearing on the hood, roof and/or trunk of the vehicle. This concern is most likely to be found in a cold weather areas just after the RAPGARD is removed at PDI. This may be caused by moisture which has been trapped and condensed between the paint and the RAPGARD. These types of stains can be removed with a heat gun or an infrared drier.

If you encounter this concern during PDI, use a heat gun or an infrared drier to apply heat to the affected area to remove the stain(s).

CONSUMER NOTICE: The information and instructions in this bulletin are intended for use by skilled technicians. Mazda technicians utilize the proper tools/equipment and take training to correctly and safely maintain Mazda vehicles. These instructions should not be performed by "do-it-yourselfers." Customers should not assume this bulletin applies to their vehicle or that their vehicle will develop the described concern. To determine if the information applies, customers should contact their nearest authorized Mazda dealership. Mazda North American Operations reserves the right to alter the specifications and contents of this bulletin without obligation or advance notice. All rights reserved. No part of this bulletin may be reproduced in any form or by any means, electronic or mechanical---including photocopying and recording and the use of any kind of information storage and retrieval system ---without permission in writing.

REPAIR PROCEDURE

1. Visually inspect the top coat surface for stains.
 - If stains are found, use a heat gun (for smaller stains) or an infrared drier (for larger stains) to heat the affected area and remove the stains.
2. Insulate all plastic and rubber parts (as shown below) using heat insulation materials (C ~ F) prior to beginning the application of heat.

- A - Body Panel
- B - Molding
- C - Aluminum foil covering all area
- D - Wet towel
- E - Folded aluminum foil
- F - Aluminum foil tape

CAUTION:

- Since this repair procedure requires the use of heat from a heat gun or infrared drier, be sure to insulate all rubber or plastic parts which are easily affected by heat from near the affected stain area.
- Use extreme care to ensure the top coat surface temperature stays below 284°F (140°C).
- To protect materials inside the cabin area (i.e. carpet, seats, etc.), also place insulation over the glass as necessary.

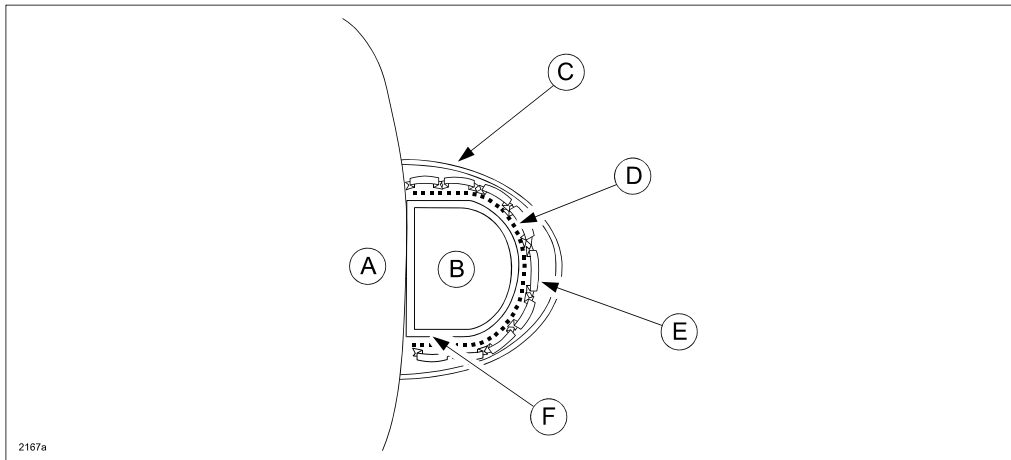

NOTE: Ensure the aluminum foil tape (F) is inserted into the edges of the molding (B) as shown below.

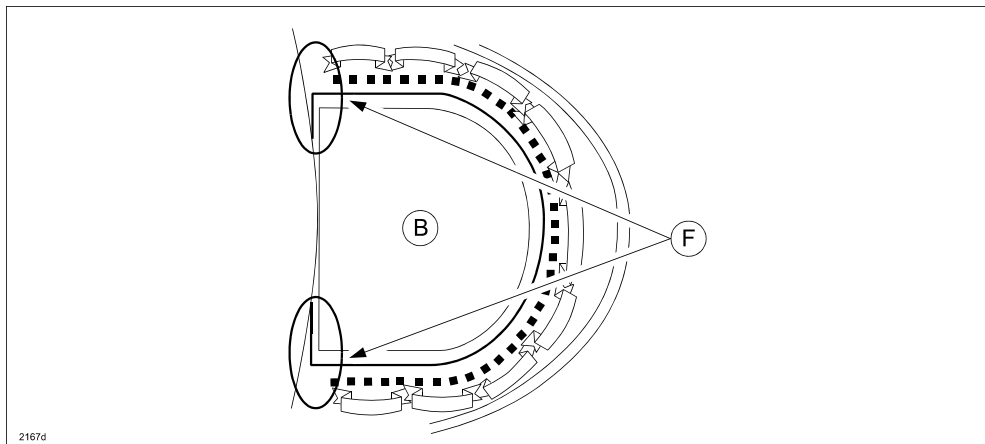

CAUTION: Refer to "PLASTIC PARTS HEAT RESISTING TEMPERATURE" section of the applicable Body Shop Manual before the repair. Repair and replacement of damaged plastic parts due to over-heating is not covered under warranty.

B3E098050000B01

| Part Name | | Code | Material Name | Heat resisting TemperatureC* {F* } | |
|-------------------------|-------------|----------|-------------------|---------------------------------------|----------|
| WINDSHIELD MOULDING | | PVC | POLYVINYLCHLORIDE | 95 {203} | |
| COWL GRILLE | | PP | POLYPROPYLENE | 95 {203} | |
| FRONT COMBINATION LIGHT | LENS | PC | POLYCARBONATE | 130 {266} | |
| | HOUSING | PP | POLYPROPYLENE | 90 {194} | |
| RADIATOR GRILLE | 4SD | STANDARD | AES | 80 {176} | |
| | | SPORT | PC/ABS | POLYCARBONATE-ABS | 80 {176} |
| | 5HB | STANDARD | AES | AES | 80 {176} |
| | | SPORT | ABS | ABS | 80 {176} |
| FRONT BUMPER | | PP | POLYPROPYLENE | 100 {212} | |
| FRONT FLAP | | PE | POLYETHYLENE | 75 {167} | |
| FRONT SIDE MAKER LIGHT | LENS | PMMA | ACRYLIC | 75 {167} | |
| | HOUSING | PC-PBT | POLYCARBONATE-PBT | 80 {176} | |
| OUTSIDE MIRROR | BASE | AAS | AAS | 88 {190} | |
| | OUTER PANEL | ABS | ABS | 88 {190} | |

2167b

PROCEDURE FOR USING HEAT GUN (for smaller stains):

1. Place a 1000 W (AC-100V) heat gun approx. 2 inches (5 cm) from the surface of the stain area and apply heat for **only 20 seconds**.
2. Adjust heat gun approx. 4 inches (10 cm) away from the surface of the stain area and apply heat for a maximum of **20 minutes**.

CAUTION: DO NOT apply heat for more than 20 minutes or damage to the body panel surface, plastic or rubber parts may occur.

3. Verify the repair.

PROCEDURE FOR USING INFRARED DRIER (for larger stains):

1. Mount an infrared drier (A) approx. 31.5 inches (80 cm) away from the surface (B) of the stain area.
2. Set the temperature of the infrared drier to 140~158° F (60~70° C) and apply heat for a maximum of **60 minutes**.

CAUTION: DO NOT apply heat for more than 60 minutes or damage to the body panel surface, plastic or rubber parts may occur.

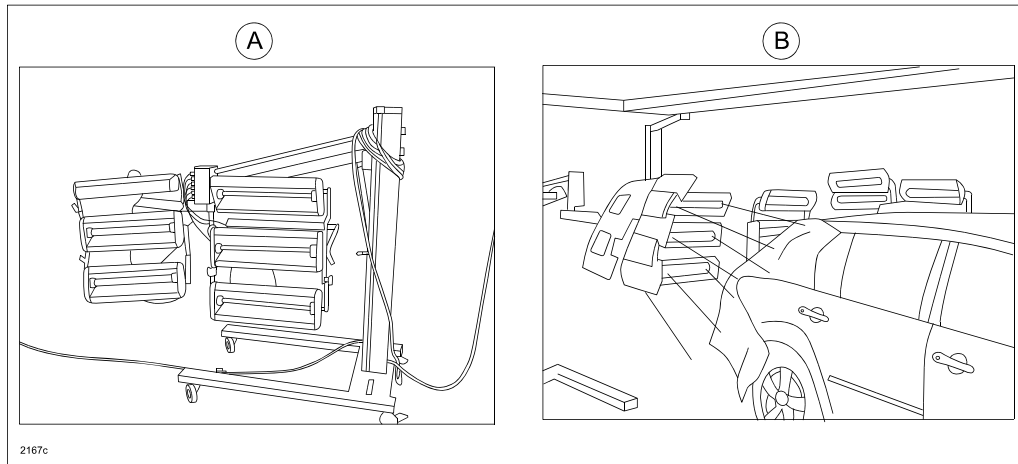

3. Verify the repair.

WARRANTY INFORMATION

NOTE:

- This warranty information applies only to verified customer complaints on vehicles eligible for warranty repair.
- This repair will be covered under Mazda's New Vehicle Limited Warranty term.
- Additional diagnostic time cannot be claimed for this repair.
- Please note that the "Period Covered" is for PDI only.

| | |
|---------------------------------|---------------------|
| Warranty Type | A |
| Symptom Code | 98 |
| Damage Code | 9X |
| Part Number Main Cause | 7777-PT-002 |
| Quantity | 0 |
| Operation Number / Labor Hours: | XX666XR1 / 0.5 Hrs. |
| Period Covered: | PDI ONLY |