

Service Information

Mazda Motor Corporation

3-1, Shinchi, Fuchu-cho, Aki-gun
Hiroshima 730-8670, Japan
TEL : 81(82)287-5323
FAX : 81(82)287-5220



Category F	Modification	Ref. No. M003/11	Page 1 of 2
Coverage <input type="checkbox"/> Distributor only <input checked="" type="checkbox"/> Please inform your dealers		Date Issued March 16, 2011	
Please convey this information to your <input type="checkbox"/> Director <input checked="" type="checkbox"/> General Manager <input checked="" type="checkbox"/> Warranty Dept. <input checked="" type="checkbox"/> Parts Dept. <input checked="" type="checkbox"/> Training Dept. <input checked="" type="checkbox"/> Field Rep.		Date Revised	
Applicable Model RX-8 (SE) with APV		Applicable Countries or Specifications Worldwide (except North America)	

Subject: Establishment of APV (Auxiliary Port Valve)

DESCRIPTION

APV (Auxiliary Port Valve) has been established as service part. Refer to Workshop Manual for replacement procedure.

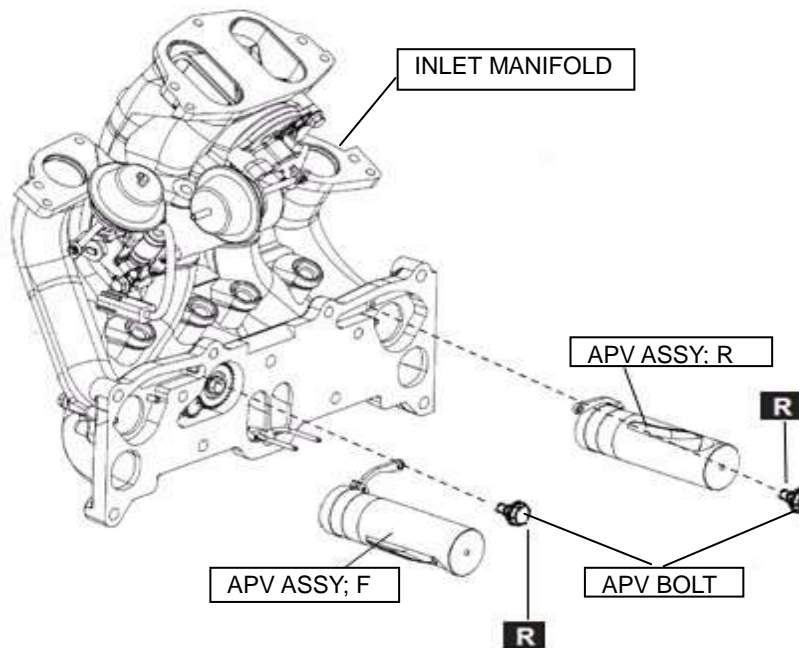

PART INFORMATION

Part Number	Part Name	Q'ty	Remark
N3H2-13B6X	VALVE ASSY-A/P/V;F	1	VIN last 6 digits smaller than 300000
N3H3-13B6X	VALVE ASSY-A/P/V;R	1	
N3R1-13B6X	VALVE ASSY-A/P/V;F	1	VIN last 6 digits bigger than 300000
N3R2-13B6X	VALVE ASSY-A/P/V;R	1	
N3H6-13B65	BOLT-A/P/V	2	APV bolts need to be replaced.

WARRANTY INFORMATION

Refer to the following chart for warranty application.

Operation No.	F0140RRX
Causal Part No.	Part number of APV used for repair
Q'ty	1
Labor Hours	7.6 Hrs (M/T, VIN last 6 digits bigger than 300000) 7.3 Hrs (A/T, VIN last 6 digits bigger than 300000) 7.7 Hrs (M/T, VIN last 6 digits smaller than 300000) 7.4 Hrs (A/T, VIN last 6 digits smaller than 300000)
Period Covered	Normal warranty period

Shinji Kanai
Manager, Technical Information Gr.
Technical Service Dept.
Mazda Motor Corporation
29C2412101 (MC Internal Use)