

© 2009 Mazda Motor of America, Inc.

Subject: CLUNK NOISE FROM SEAT WHEN BRAKING	Bulletin No: 09-060/09
	Last Issued: 10/23/2009

APPLICABLE MODEL(S) / VINS

- 2006-2010 MX-5
- 2004-2010 RX-8
- 2004-2010 MAZDA3
- 2006-2010 MAZDA5
- 2003-2010 MAZDA6
- 2007-2010 CX-7
- 2007-2010 CX-9

DESCRIPTION

Some vehicles may exhibit a clunk noise coming from the front seat when braking. The noise may be caused by both seat rails (A) being out of position.

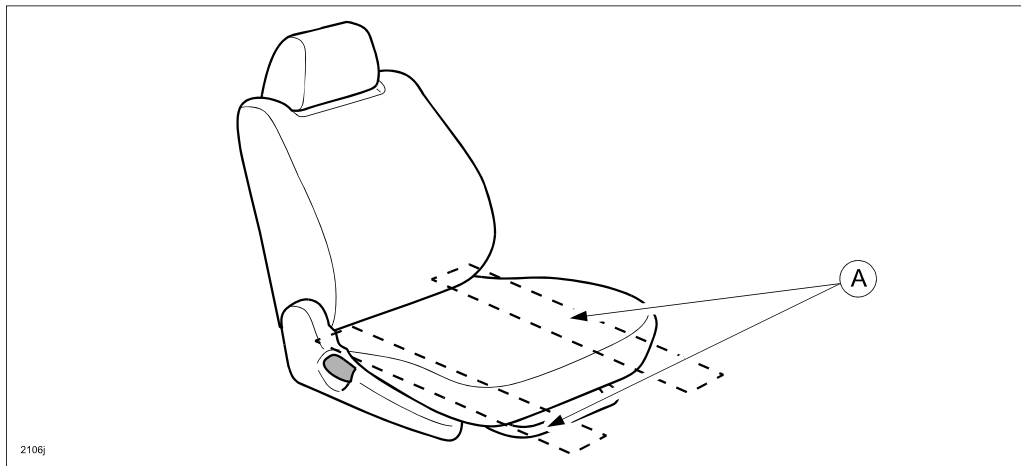

Customers having these concerns should have their vehicle repaired using the following repair procedure.

CONSUMER NOTICE: The information and instructions in this bulletin are intended for use by skilled technicians. Mazda technicians utilize the proper tools/equipment and take training to correctly and safely maintain Mazda vehicles. These instructions should not be performed by "do-it-yourselfers." Customers should not assume this bulletin applies to their vehicle or that their vehicle will develop the described concern. To determine if the information applies, customers should contact their nearest authorized Mazda dealership. Mazda North American Operations reserves the right to alter the specifications and contents of this bulletin without obligation or advance notice. All rights reserved. No part of this bulletin may be reproduced in any form or by any means, electronic or mechanical---including photocopying and recording and the use of any kind of information storage and retrieval system ---without permission in writing.

REPAIR PROCEDURE

1. Verify customer complaint.
2. Loosen the seat assembly according to the appropriate MS3 online instructions or Workshop Manual.
3. Insert both left and right locator pins (B) (front side) into the floor.

NOTE: Seat locator pins are located in the front side of the seat rails.

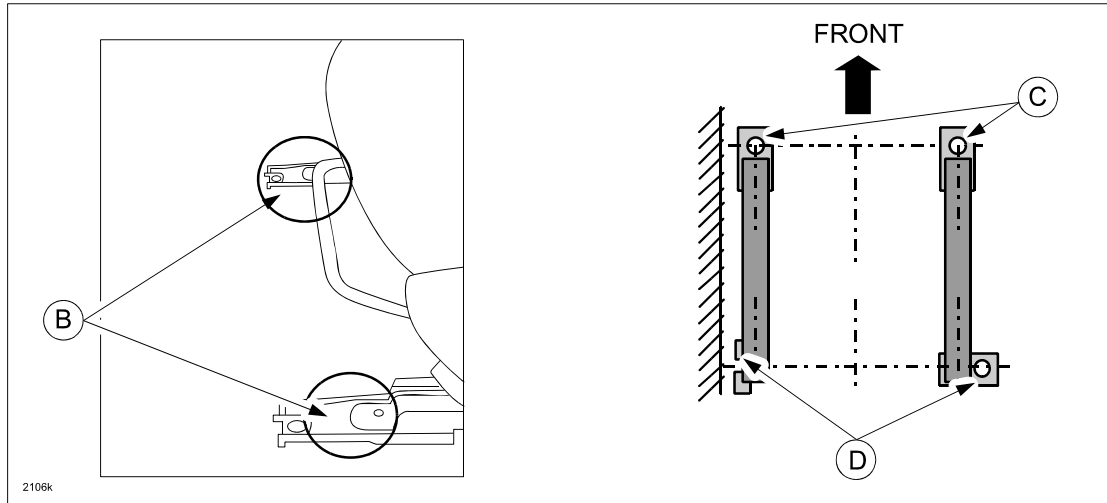

4. Move the seat slider forward by approx. 1/3 of the rail, then tighten bolts (D) on the rear side of seat slider rails.
5. Move the seat slider rearward by approx. 1/3 of the rail, then tighten bolts (C) on front side of seat slider rails.

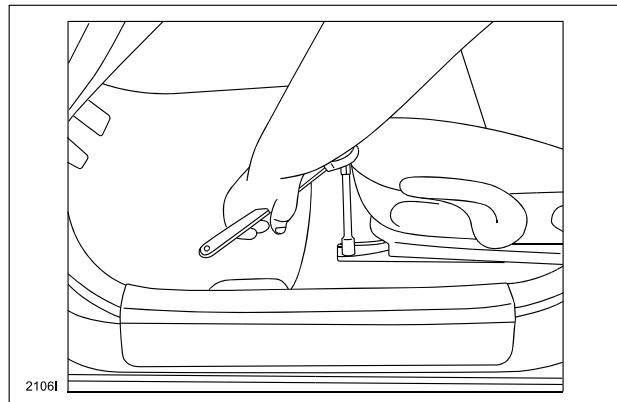

6. After tightening all bolts to specified torque according to the appropriate MS3 online instructions or Workshop Manual, shake seat back and forth to verify seat slider is firmly installed.
7. Verify repair.

WARRANTY INFORMATION

NOTE:

- This warranty information applies only to verified customer complaints on vehicles eligible for warranty repair.
- This repair will be covered under Mazda's New Vehicle Limited Warranty term.
- Additional diagnostic time cannot be claimed for this repair.

Warranty Type	A
Symptom Code	82
Damage Code	9H
Part Number Main Cause	7777-NS-ST4
Quantity	0
Operation Number / Labor Hours:	XXE54XTX / 0.2 Hrs. (Bolt re-tightening)