

<b>Subject:</b>  STAINS FOUND ON PAINT DURING PDI	<b>Bulletin No:</b> 09-036/09
	<b>Last Issued:</b> 11/12/2009

## BULLETIN NOTE

- This bulletin supersedes the previous bulletins 09-015/04 issued 04/26/04 and 05/14/04, 09-004/05 issued 02/18/05 and 09/23/05 and bulletin 09-036/09 issued 07/17/09 and 07/27/09. The DESCRIPTION and REPAIR PROCEDURE have been revised.
- Changes are noted below in Red beside the change bar.

## APPLICABLE MODEL(S)/VINS

2009-2010 MX-5  
2009-2010 RX-8  
2009-2010 MAZDA3  
2009-2010 MAZDA5  
2009-2010 MAZDA6  
2009-2010 CX-7  
2009-2010 CX-9

## DESCRIPTION

Some vehicles may experience stains appearing on the hood, roof and/or trunk of the vehicle. This concern is most likely to be found in a cold weather areas just after the RAPGARD is removed at PDI. This may be caused by moisture which has been trapped and condensed between the paint and the RAPGARD. These types of stains can be removed with a heat gun or an infrared drier.

If you encounter this concern during PDI, use a heat gun or an infrared drier to apply heat to the affected area to remove the stain(s).

## REPAIR PROCEDURE

1. Visually inspect the top coat surface for stains.
  - If stains are found, use a heat gun (for smaller stains) or an infrared drier (for larger stains) to heat the affected area and remove the stains.
2. Insulate all plastic and rubber parts (as shown below) using heat insulation materials (C ~ F) prior to beginning the application of heat.

- A - Body Panel
- B - Molding
- C - Aluminum foil covering all area
- D - Wet towel
- E - Folded aluminum foil
- F - Aluminum foil tape

### CAUTION:

- Since this repair procedure requires the use of heat from a heat gun or infrared drier, be sure to insulate all rubber or plastic parts which are easily affected by heat from near the affected stain area.
- Use extreme care to ensure the top coat surface temperature stays below 284°F (140°C).
- To protect materials inside the cabin area (i.e. carpet, seats, etc.), also place insulation over the glass as necessary.

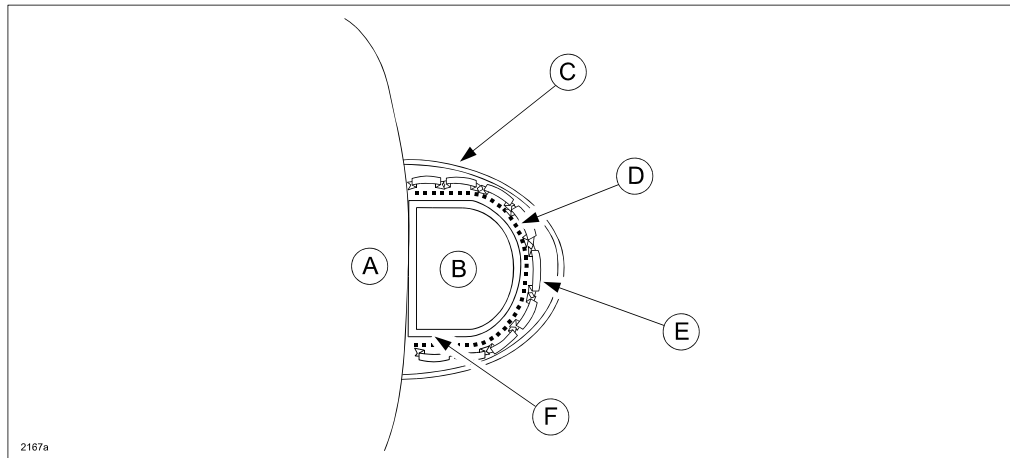

**NOTE:** Ensure the aluminum foil tape (F) is inserted into the edges of the molding (B) as shown below.

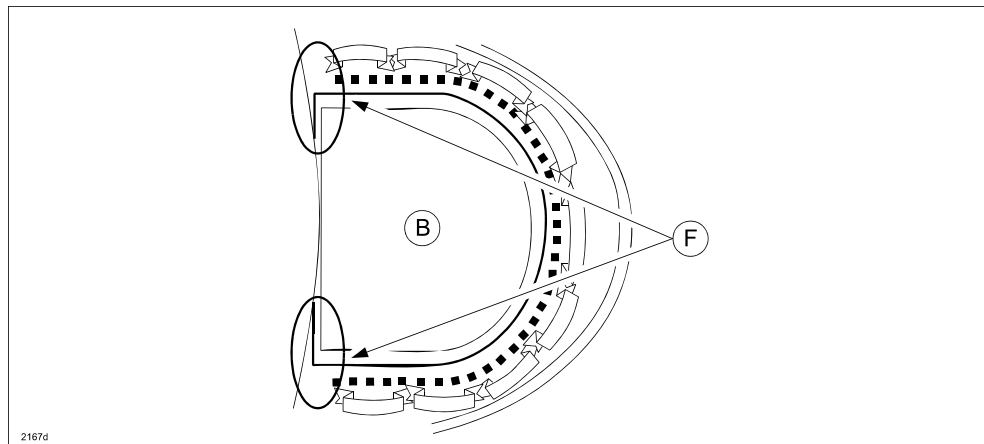

**CAUTION:** Refer to "PLASTIC PARTS HEAT RESISTING TEMPERATURE" section of the applicable Body Shop Manual before the repair. Repair and replacement of damaged plastic parts due to over-heating is not covered under warranty.

B3E098050000B01

Part Name		Code	Material Name	Heat resisting TemperatureC* {F° }	
WINDSHIELD MOULDING		PVC	POLYVINYLCHLORIDE	95 {203}	
COWL GRILLE		PP	POLYPROPYLENE	95 {203}	
FRONT COMBINATION LIGHT	LENS	PC	POLYCARBONATE	130 {266}	
	HOUSING	PP	POLYPROPYLENE	90 {194}	
RADIATOR GRILLE	4SD	STANDARD	AES	80 {176}	
		SPORT	PC/ABS	POLYCARBONATE-ABS	80 {176}
	5HB	STANDARD	AES	AES	80 {176}
		SPORT	ABS	ABS	80 {176}
FRONT BUMPER		PP	POLYPROPYLENE	100 {212}	
FRONT FLAP		PE	POLYETHYLENE	75 {167}	
FRONT SIDE MAKER LIGHT	LENS	PMMA	ACRYLIC	75 {167}	
	HOUSING	PC-PBT	POLYCARBONATE-PBT	80 {176}	
OUTSIDE MIRROR	BASE	AAS	AAS	88 {190}	
	OUTER PANEL	ABS	ABS	88 {190}	

2167b

**PROCEDURE FOR USING HEAT GUN (for smaller stains):**

1. Place a 1000 W (AC-100V) heat gun approx. 2 inches (5 cm) from the surface of the stain area and apply heat for **only 20 seconds**.
2. Adjust heat gun approx. 4 inches (10 cm) away from the surface of the stain area and apply heat for a maximum of **20 minutes**.

**CAUTION:** DO NOT apply heat for more than 20 minutes or damage to the **body panel surface, plastic or rubber** parts may occur.

3. Verify the repair.

**PROCEDURE FOR USING INFRARED DRIER (for larger stains):**

1. Mount an infrared drier (A) approx. 31.5 inches (80 cm) away from the surface (B) of the stain area.
2. Set the temperature of the infrared drier to 140~158° F (60~70° C) and apply heat for a maximum of **60 minutes**.

**CAUTION:** DO NOT apply heat for more than 60 minutes or damage to the body panel surface, plastic or rubber parts may occur.

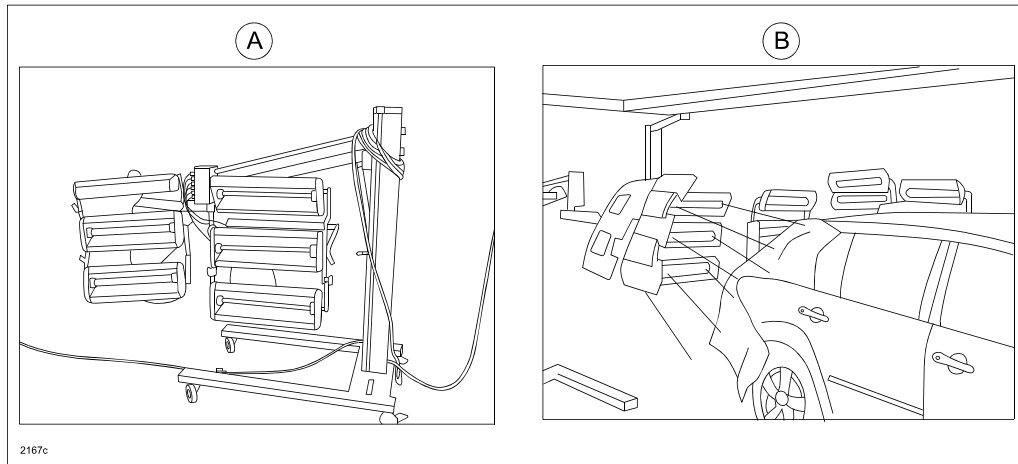

3. Verify the repair.

**WARRANTY INFORMATION**

**NOTE:**

- This warranty information applies only to verified customer complaints on vehicles eligible for warranty repair.
- This repair will be covered under Mazda's New Vehicle Limited Warranty term.
- Additional diagnostic time cannot be claimed for this repair.
- Please note that the "Period Covered" is for PDI only.

Warranty Type	A
Symptom Code	98
Damage Code	9X
Part Number Main Cause	7777-PT-002
Quantity	0
Operation Number / Labor Hours:	XX666XR1 / 0.5 Hrs.
Period Covered:	PDI ONLY