





GENUINE FRONT STABILIZER

INSTALLATION AND USER'S INSTRUCTIONS

Thank you for purchasing a genuine Mazda accessory.
Before removal and installation, be sure to thoroughly read these instructions.
Please read the contents of this booklet in order to properly install and use the front stabilizer. Your safety depends on it.
Keep these instructions with your vehicle records for future reference.

WARNING

- There are several  **WARNING** and  **CAUTION** sections in this booklet concerning safety when installing or removing the front stabilizer. Always read and follow them in order to prevent injuries, accidents, and possible damage to the vehicle.
 -  **WARNING:** Indicates a situation in which serious injury or death could result if the warning is ignored.
 -  **CAUTION:** Indicates a situation in which bodily injury or damage to the vehicle could result if the caution is ignored.
- Do not modify the front stabilizer.
- Do not install the front stabilizer in any way other than described in the following instructions.
- If in any doubt, please ask your Mazda dealer to install the accessory in order to prevent errors in installation.
- If you have any questions about the use of the accessory, ask your Mazda dealer for proper advice before using it.
- Mazda and its suppliers are not responsible for injuries, accidents, and damage to persons and property that arise from the failure of the dealer or installer to follow these instructions.
- To ensure safety and reliability of the work, installation, removal and disposal work must be carried out by an Authorized Mazda Dealership.
- Be careful not to lose removed parts, and be sure that they are kept free from scratches, grease or other dirt.

PART NAME: FRONT STABILIZER

PART NUMBER: QSEA 34 151

VEHICLE: Mazda RX-8

NOTE

To the dealer

- Please turn over these instructions to the customer after installation.

To the customer

- Keep these instructions after installation. The instructions may be necessary for installing other optional parts or removal of this accessory.
- Should the vehicle or this accessory be resold, always leave these instructions with it for the next owner.

1 PARTS

Note

- Verify that the kit includes all the following parts and that they are free of dirt, scratches, or damage.
- If bushing replacements are required, order OE service parts.

Part name	Qty.
Front stabilizer	1

CAUTION

- For the standard suspension, two stabilizer bushes (F157 34 156) are required.

2 BEFORE INSTALLATION

REQUIRED TOOLS

Prepare the following tools or items before installation.

- ★Wrench ★49 T028 3A0 (Special tool) ★Rubber grease

3 ORIGINAL FRONT STABILIZER REMOVAL

CAUTION

- Performing the following procedures without first removing the ABS wheel-speed sensor may possibly cause an open circuit in the wiring harness if it is pulled by mistake. Before performing the following procedures, remove the ABS wheel-speed sensor (axle side) and fix it to an appropriate place where the sensor will not be pulled while the installation work is performed.

1. Remove the following parts in the order indicated in the figure.

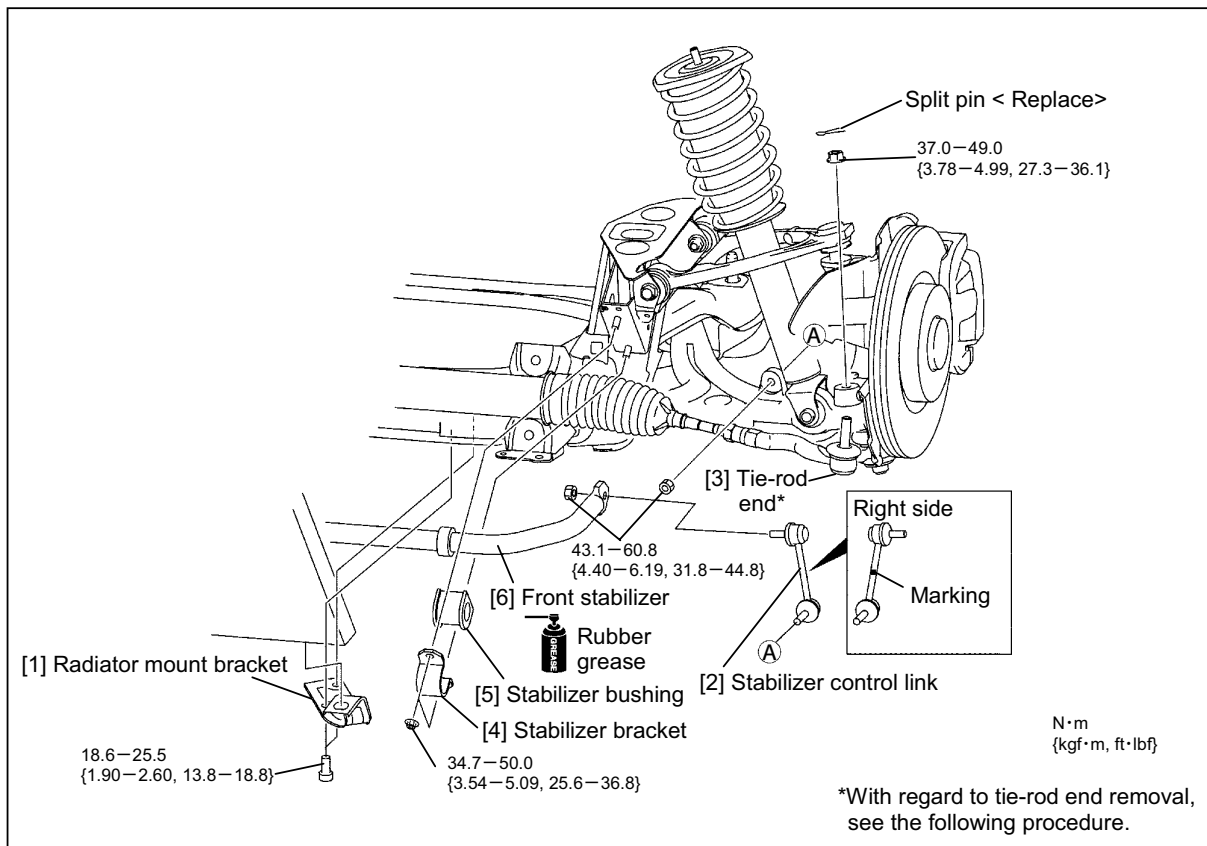

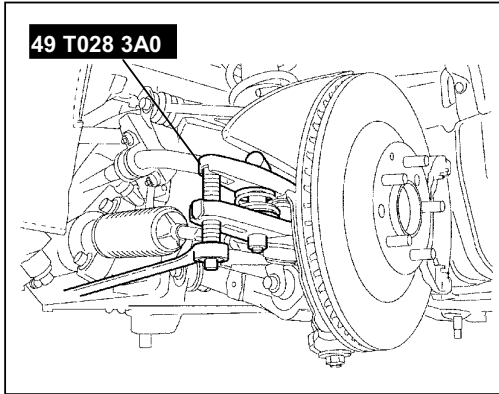

Tie-rod end removal

1. Remove the outer ball joint locknut.
2. Detach the outer ball joint from the steering knuckle using the special tool (49 T028 3A0).

4 FRONT STABILIZER INSTALLATION

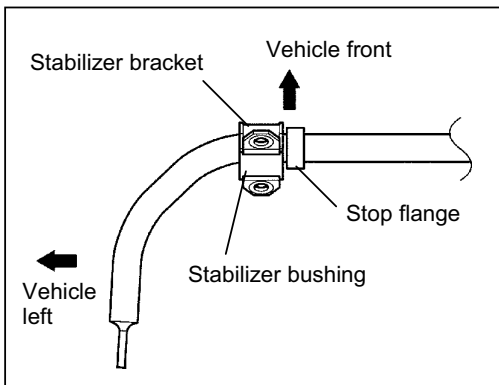

Stabilizer bracket installation

1. Apply rubber grease to the inner side of the stabilizer bushing.
2. Align the outer side of the stabilizer slide stopper with the stabilizer bushing.
3. Install the stabilizer bracket.

Removed parts reinstallation

1. Reinstall the parts removed in section [3] in the reverse or order of removal.