





GENUINE SIDE SKIRT SET

INSTALLATION AND USER'S INSTRUCTIONS

Thank you for purchasing a genuine Mazda accessory.
Before removal and installation, be sure to thoroughly read these instructions.
Please read the contents of this booklet in order to properly install and use the side skirt set.
Your safety depends on it.
Keep these instructions with your vehicle records for future reference.

WARNING

- There are several  **WARNING** and  **CAUTION** sections in this booklet concerning safely when installing or removing the side skirt set. Always read and follow them in order to prevent injuries, accidents, and possible damage to the vehicle.
 -  **WARNING:** Indicates a situation in which serious injury or death could result if the warning is ignored.
 -  **CAUTION:** Indicates a situation in which bodily injury or damage to the vehicle could result if the caution is ignored.
- Do not modify the side skirt set.
- Do not install the side skirt set in any way other than described in the following instructions.
- If in any doubt, please ask your Mazda dealer to install the accessory in order to prevent errors in installation.
- If you have any questions about the use of the accessory, ask your Mazda dealer for proper advice before using it.
- Mazda and its suppliers are not responsible for injuries, accidents, and damage to persons and property that arise from the failure of the dealer or installer to follow these instructions.
- To ensure safety and reliability of the work, installation, removal and disposal work must be carried out by an Authorized Mazda Dealership.
- Be careful not to lose removed parts, and be sure that they are kept free from scratches, grease or other dirt.

PART NAME: SIDE SKIRT SET
PART NUMBER: QSEA 70 900
VEHICLE: Mazda RX-8

NOTE

To the dealer

- Please turn over these instructions to the customer after installation.

To the customer

- Keep these instructions after installation. The instructions may be necessary for installing other optional parts or removal of this accessory.
- Should the vehicle or this accessory be resold, always leave these instructions with it for the next owner.

1 INSTALLATION VIEW

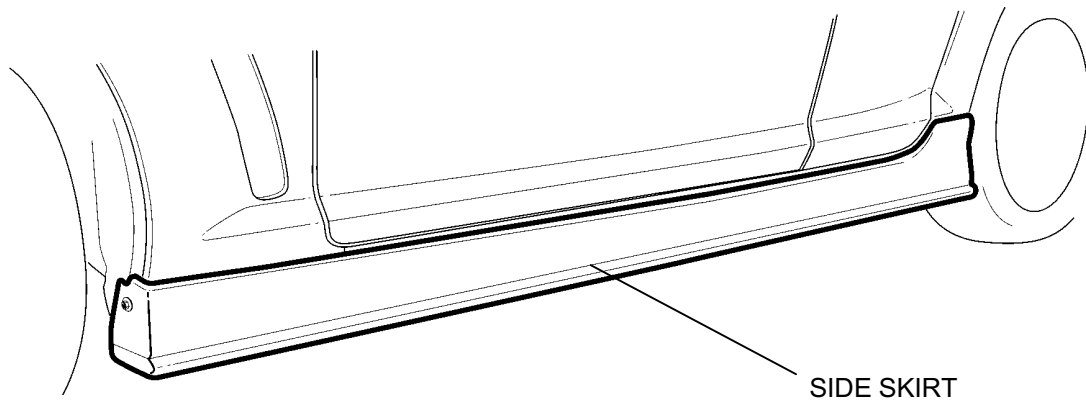

2 PARTS

Note

- Before installation, verify that the kit includes all the following parts and that they are free of dirt, scratches, or damage.

Part	Part name	Spec	Qty.	Part	Part name	Spec	Qty.
	Side skirt (RH, LH)	Same as the body color	1 ea.		Clip	-	4
	Screw	M6 x 20	2		Bolt	M5 x 15	4
	Speed nut	-	2		Fastener A	Resin fastener, clear	6
	Fastener B	Resin fastener, black	8		Urethane seal	Urethane	12
	Installation and user's instructions	Paper	1		Paper pattern set (A, B, C, D)	Paper patterns A, B, C (A3 size) Paper pattern D (A4 size)	4

3 BEFORE INSTALLATION

REQUIRED TOOLS

Prepare the following tools or items before installation.

- ★ Drill bit (3 mm, 8 mm)
- ★ Clean rags
- ★ Round file
- ★ Cutter
- ★ Oil base pen
- ★ Phillips screwdriver
- ★ Fastener remover
- ★ Hacksaw
- ★ Drill
- ★ Vacuum cleaner
- ★ IPA (Isopropyl alcohol)
- ★ Masking tape
- ★ Scissors
- ★ Duct tape

⚠ WARNING

When installing the accessory, park the vehicle on level ground, use wheel blocks, and apply the side brake securely.

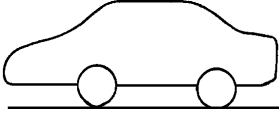

⚠ CAUTION

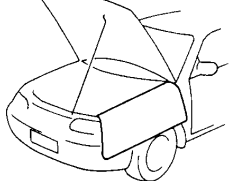
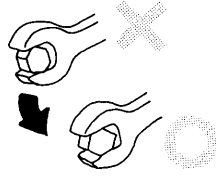
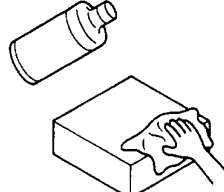
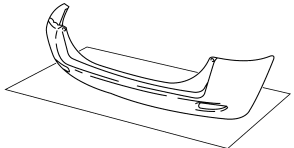
<p>Be sure to cover the vehicle body with protectors or mats to prevent stains, scratches and damage when removing/installing the vehicle parts.</p>	<p>Using improper tools may cause damage and/or broken parts. Use the correct tool for the job.</p>	<p>Before installing the parts with double-sided adhesive tape, wipe dust and dirt off the surface where the double-sided adhesive tape contacts. Otherwise, the parts may come off, resulting in a malfunction.</p>	<p>Put the removed parts and the parts in the kit on the protective sheet to prevent scratches.</p>
			

⚠ CAUTION

- Always perform the installation work with two people.

⚠ WARNING

- Refer to the Workshop Manual for removal and installation of vehicle parts. Not following the procedures for removal/installation in the Workshop Manual could result in an accident or vehicle malfunction.

4

PART REMOVAL

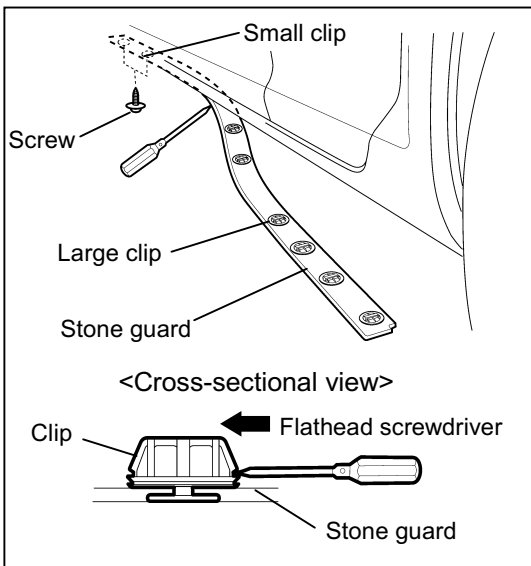
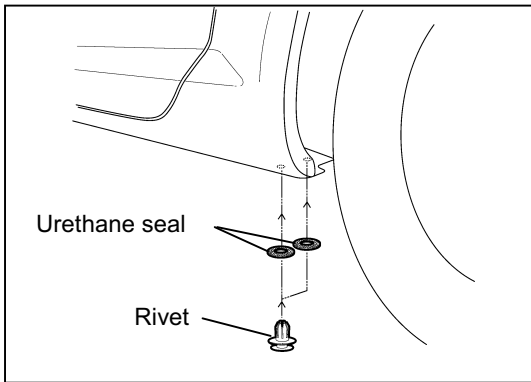
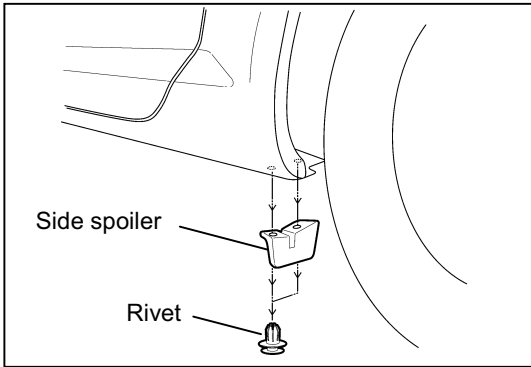

Preparation before installation

Note

- The figures show the left side, however, perform the same procedure for the right side.

1. Remove the rivets fastening the side spoiler, and then remove the side spoiler from the vehicle body.
2. Affix the urethane seals to the holes for the removed rivets and reinstall the rivets.

Stone guard removal (18-inch wheel vehicle)

1. Remove the screws for the small clips that are first and second from the front end of the stone guard.
2. Using a flathead screwdriver, remove the large clips (11) fastening the stone guard one by one starting from the rear end, and then remove the stone guard completely.
3. Remove the small clips (black) that are first and second from the front end.

Note

- Starting from the rear and working towards the vehicle front, each of the large clips can be removed easily by inserting a flathead screwdriver in the side of the clip. (The clips beginning third from the front are the large clips.)
- Starting from the rear and working towards the vehicle front, each of the small clips can be removed easily by inserting a flathead screwdriver from the front and rear. (The clips first and second from the front are the small clips.)

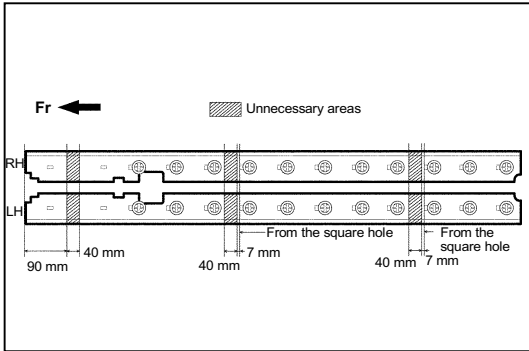

4. Cut the stone guard at the points shown in the figure.

⚠ WARNING

- Always handle the hacksaw and cutter carefully. Otherwise, serious injury could result.

⚠ CAUTION

- Always cut the stone guard as specified. Otherwise, the accessory may not be installed properly.

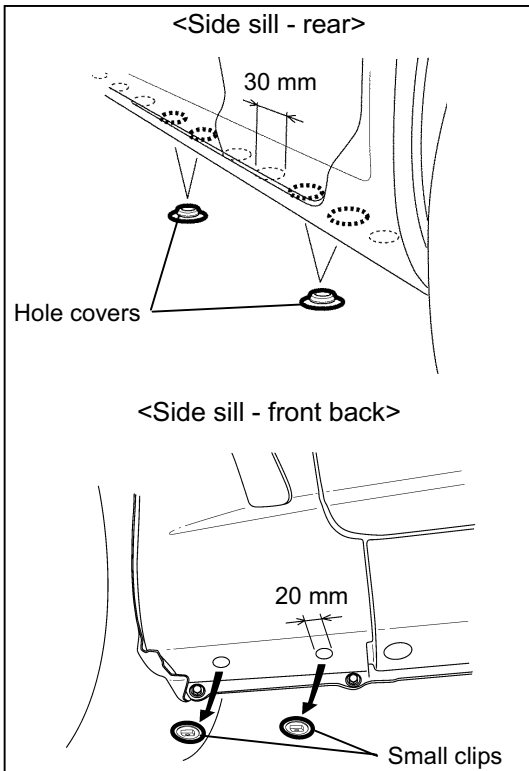

Hole cover removal (16-inch wheel vehicle)

1. Remove the hole covers on the vehicle body second, third, sixth, and seventh the rear end.
2. Remove the small clips first and second from the front end.

5 SIDE SKIRT SET INSTALLATION

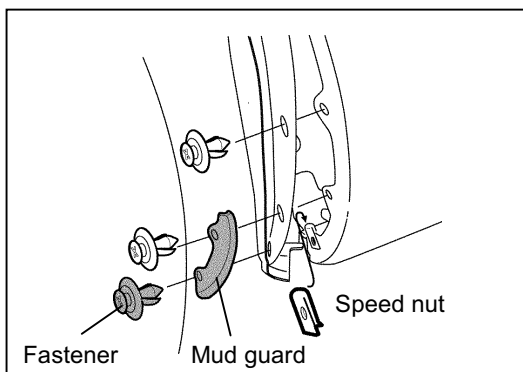

Installation of speed nuts to front wheel arch

1. For equipped vehicles, remove the front wheel arch fasteners (3) from the vehicle and mud guard.
2. Bend back the inner cover and install the speed nut (1).
3. Reinstall the fasteners (2) removed from the vehicle to their original positions.

Note

- The fastener and mud guard that were installed in the lowest position are not reused. ( not reused)

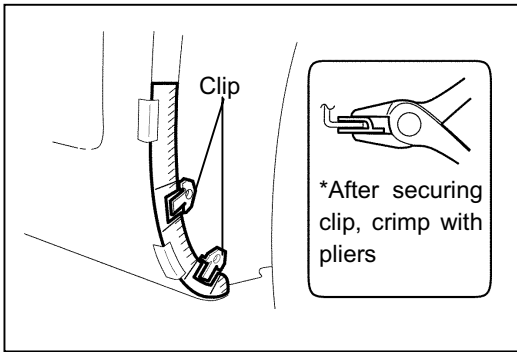

Installation of clips to rear wheel arch

1. Cut out template D, and after securing the clips (2) by aligning it with the shape of the wheel arch, remove the template.

⚠ CAUTION

- Always adhere the template to the position shown in the figure. Adhering the template outside the designated position could result in the accessory not being installed correctly.

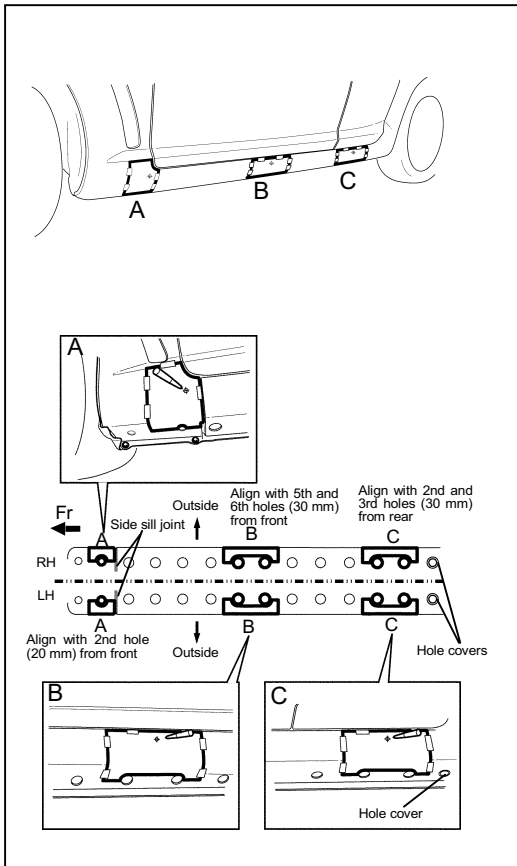

Drilling position marking for vehicle side

1. Wipe off oil or dust from the side skirt installation area on the vehicle using isopropyl alcohol (IPA).
2. Cut out templates A to C.
3. Align with the vehicle and adhere, and after marking the drilling position using a punch, remove the templates.

⚠ CAUTION

- Be sure to attach the paper patterns as shown in the figure. If they are attached in a position other than specified, the accessory may not be installed properly.
- When marking with a punch, be careful not to apply too much force. Otherwise, the vehicle body may be deformed.

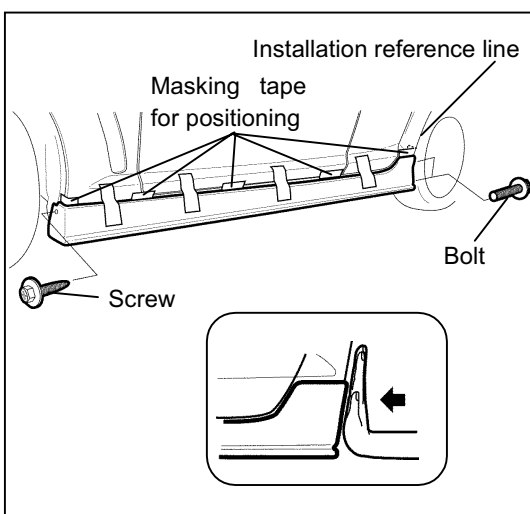

Drilling position marking for lower part of vehicle

1. Align the side skirt with the edge of the side sill and temporarily install it to the vehicle using the screw and bolt.
2. Verify that there are no gaps between the upper side skirt and the vehicle body, and position the side skirt using masking tape.

Note

- The edge of the side sill is used for installation positioning. Always install the side skirt attaching it to the edge of the side sill.

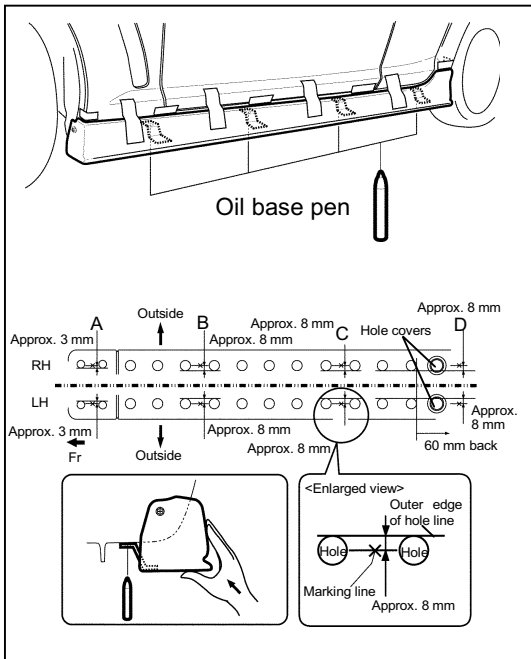

3. Mark with an oil base pen.

Note

- Perform the marking procedure while pressing the side.
- Refer to the figure for the marking line and drill hole positions.

4. Detach the temporarily installed screw and bolt for the side skirt, and then remove the side skirt.

CAUTION

- Leave the masking tape used for positioning as it is.

5. Tap the punch into the positions marked with the oil base pen.

CAUTION

- Do not tap the punch with excessive force. It could deform the side sill.

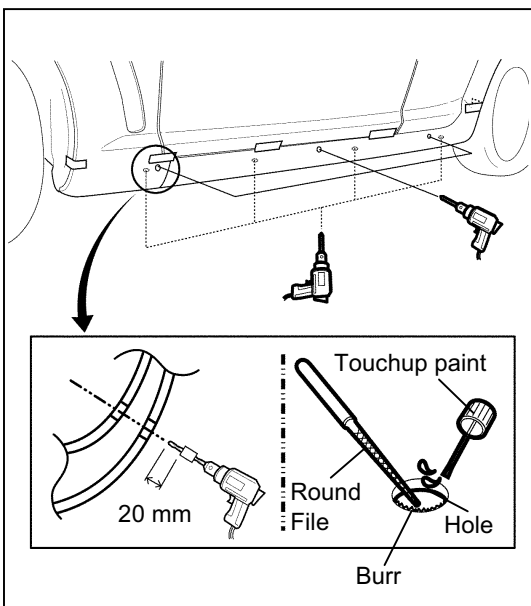

Body hole drilling

1. Wipe off oil or dust from the skirt installation area on the vehicle using isopropyl alcohol (IPA).
2. Drill the 3 mm pilot holes marked with the punch, and then the 8 mm pilot holes.

CAUTION

- Be careful when handling drills and other sharp objects so as not to cause injury.
- Create a drilling guide by adhering duct tape to the area 20 mm from the drill bit end.
- There is double steel plating in the area. Drill the holes through both steel plates. Otherwise fasteners A and B (described in following procedure) will not be completely secured.
- If chips produced during drilling fall into the side sill or the vehicle body, always remove them with a vacuum cleaner. Otherwise, they can cause rust or noise.
- Always remove burrs around the hole with a round file and apply touchup paint to prevent rust.

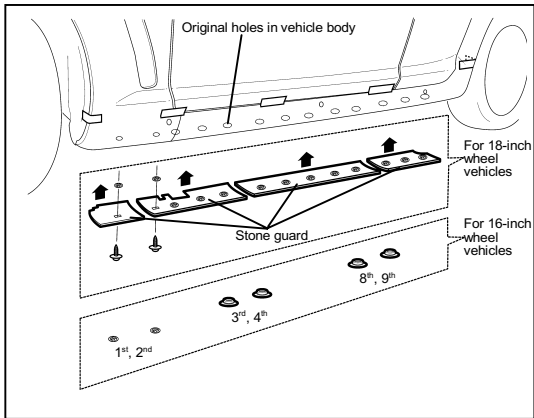

Stone guard, hole cover reinstallation

1. Reinstall the small clips 1st and 2nd from the front.
2. Reinstall the removed stone guard and hole covers to their original positions.

(18-inch wheel vehicles)

Reinstall the screws 1st and 2nd from the front.

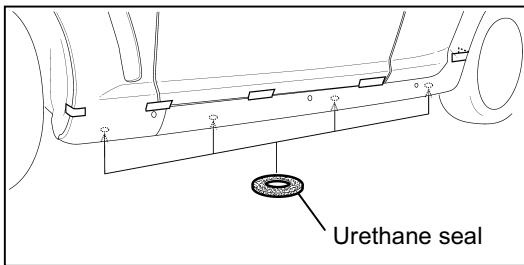

Side skirt set installation

1. Wipe off oil or dust from the side skirt installation area on the vehicle using isopropyl alcohol (IPA).
2. Adhere the urethane seals (4) in the positions shown in the figure.

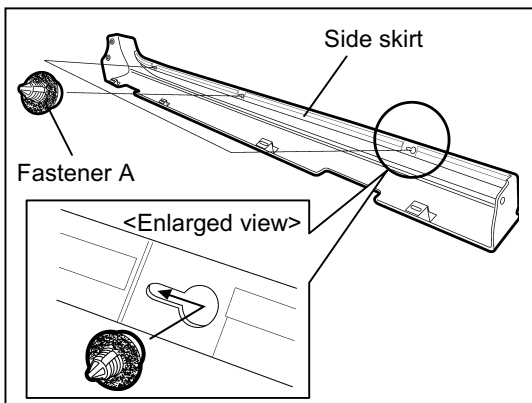

3. Install fasteners A (3) to the side skirt.

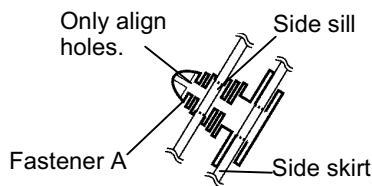
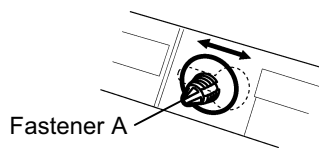
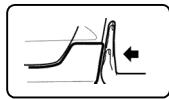
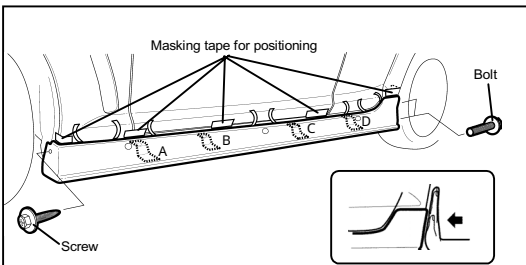

*If holes are not aligned, adjust the position by sliding side skirt back and forth along direction of vehicle travel.



Bracket attached to side skirt

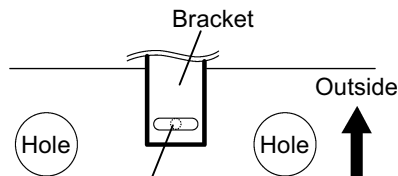

*Check if bracket hole and side sill hole are aligned.

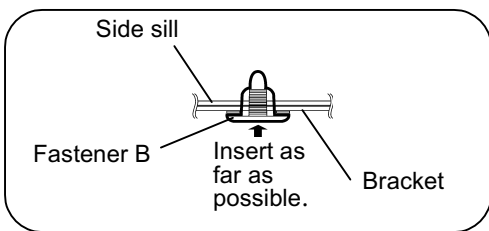
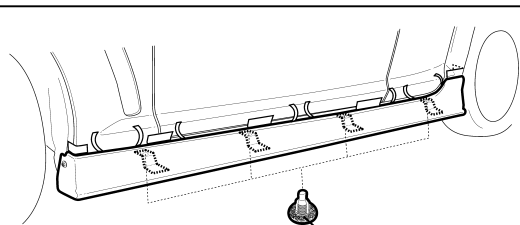

4. Peel back 50 to 60 mm of the paper backing from each piece of the double-sided adhesive tape and turn back the paper backings outward.
5. Align the side skirt to the positioning masking tape with the edge of the side sill, and temporarily secure the side sill with the screw and bolt.

Note

- The edge of the side sill is used for installation positioning. Always install the side skirt attaching it to the edge of the side sill.

CAUTION

- Do not completely insert side skirt fastener A into the installation hole.

Note

- If the hole positions are not aligned, adjust by sliding the side skirt forward and back.

6. Align fasteners B (4) with the bracket holes on the lower side of the side skirt and the hole positions on the lower side of the vehicle body, and insert completely.

CAUTION

- Be sure to insert fasteners B as far as they will go. If they are not inserted completely, the side skirt may not be installed properly and may come off.

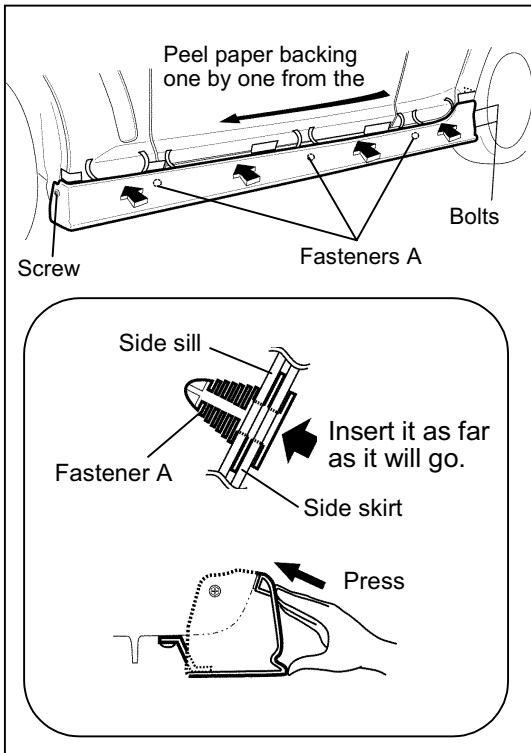

7. Peel the paper backing one by one from the edge of the side sill, and press the side skirt to the side sill so that there are no gaps. At the same time, completely press in fasteners A from the side sill edge.

CAUTION

- Be sure to insert fasteners A as far as possible.
- Firmly press the adhesive tape so that there are no gaps between the side sill and the vehicle body.

8. Tighten the side skirt screw and bolt.

Tightening Torque

Screw: 4.2 – 6.2 N·m { 43 – 63 kgf·cm , 38 – 54 in·lbf }

Bolt: 2.5 – 3.5 N·m { 26 – 35 kgf·cm , 23 – 30 in·lbf }

9. Remove the masking tape used for positioning.

6 HANDLING CAUTION

CAUTION

- If the accessory gets dirty, clean it with a neutral detergent. Never use organic solvents such as thinner or benzene.
- Never step on the aero parts when the vehicle is stopped.
- Decelerate and drive carefully when driving over bumpy roads. Otherwise the accessory could be damaged.