



GENUINE ACCESSORIES

INSTALLATION INSTRUCTIONS

PART NUMBER

APPLICABLE MODELS

0000-88-K12

REAR ROTARY CREST

2004 > RX-8

KIT CONTENTS:



Rear Rotary Crest

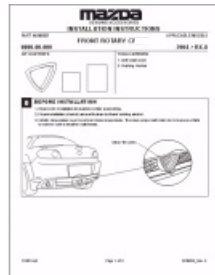

Instructions



3M 4298
Adhesive Promoter

TOOLS NEEDED:

1. Soft Clean Cloth
2. Isopropyl (rubbing) alcohol

0 BEFORE INSTALLATION

1. Read entire installation instructions before proceeding.
2. Clean installation (shaded) area with clean cloth and isopropyl (rubbing) alcohol .
3. Vehicle temperature must be at least room temperature.

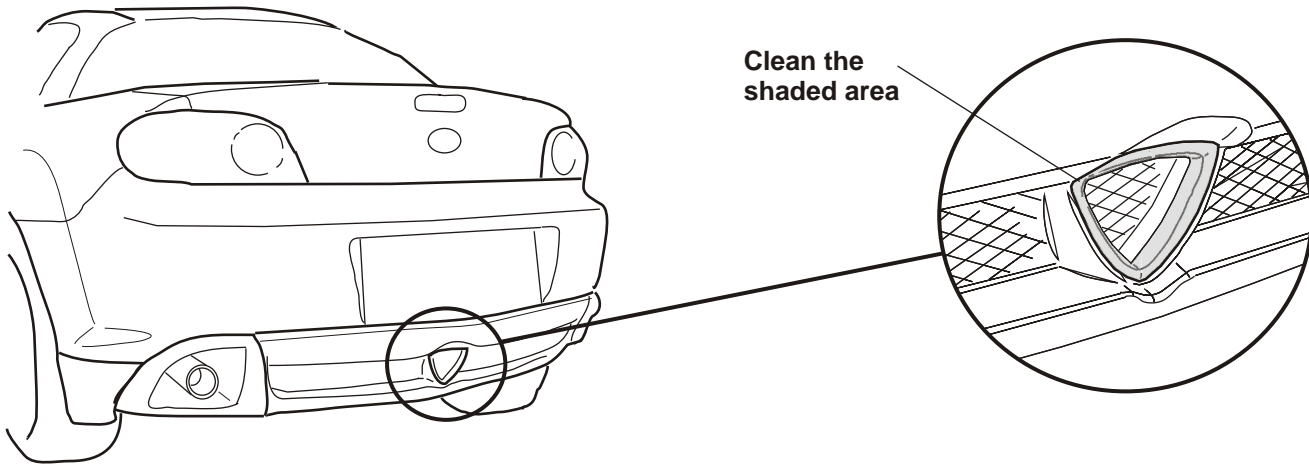

1

INSTALLATION

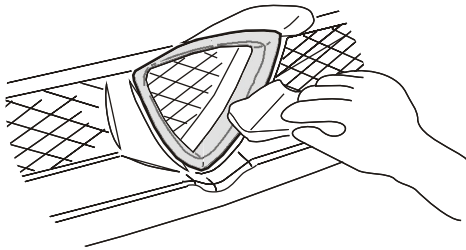

1. Apply kit supplied adhesive promoter to installation (shaded) area only. Allow to dry.

CAUTION: Only a thin layer of promoter is required. Drying time will range from 30 ~ 90 seconds depending on temperature.

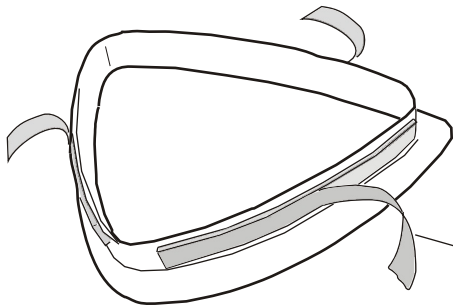

**Peel off tape backing
(3) places**

2. Completely remove the backing from the adhesive tape on all three sides.

CAUTION: Do not get any fingerprints or debris on the tape.

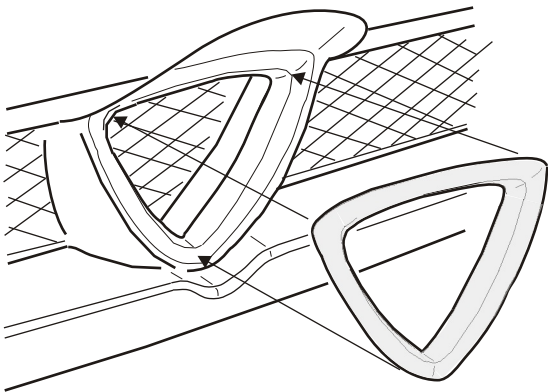

3. Carefully Install the rotary crest to the vehicle surface as shown.

4. Apply pressure for 30 seconds to ensure proper adhesion and a good fit.

2

AFTER INSTALLATION

1. Check for proper fit.
2. Clean installation area free of any fingerprints.