



GENUINE ACCESSORIES

# INSTALLATION INSTRUCTIONS

PART NUMBER

APPLICABLE MODELS

**0000-88-K11**

## FRONT ROTARY CREST

**2004 > RX-8**

### KIT CONTENTS:

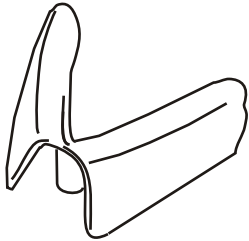

Front Rotary  
Crest



Fastener  
Qty. (2)

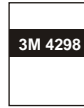

3M 4298  
Adhesive Promoter



Instructions

### TOOLS NEEDED:

1. Soft Clean Cloth
2. Isopropyl (rubbing) alcohol

## 0 BEFORE INSTALLATION

1. Read entire installation instructions before proceeding.
2. Clean installation (shaded) area with clean cloth and isopropyl (rubbing) alcohol .
3. Vehicle temperature must be at least room temperature.

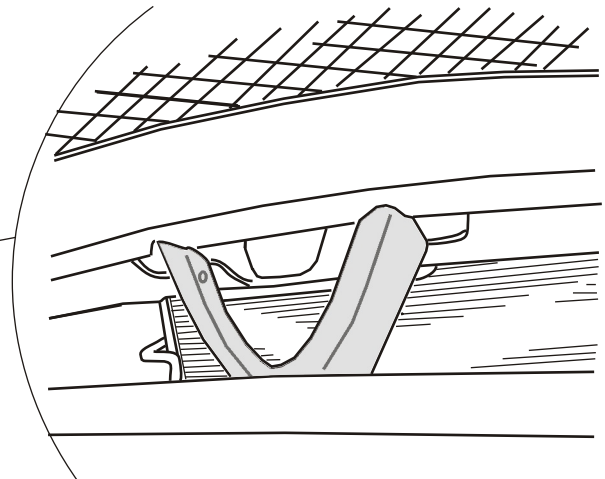
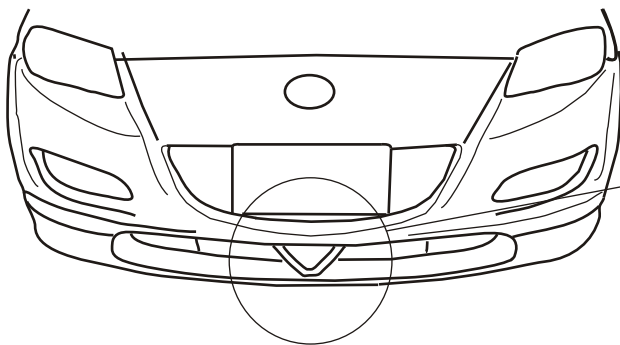

# 1 CREST PREPERATION

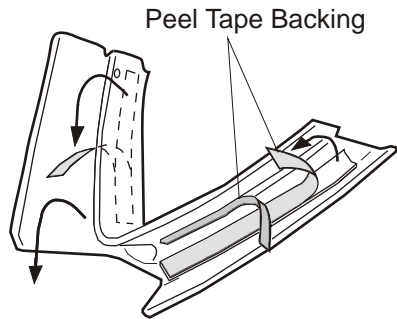

1. Apply kit supplied adhesive promoter to installation area only. Allow to dry.

**CAUTION:** Only a thin layer of promoter is required. Drying time will range from 30 ~ 90 seconds depending on temperature.

2. Completely remove the backing from the double-sided adhesive tape as shown.

**CAUTION:** Do not get any fingerprints or debris on the tape.

# 2 CREST INSTALLATION

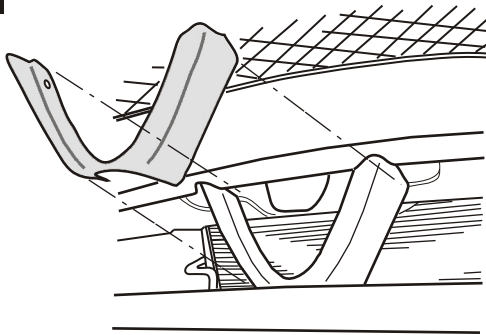

## Installation area cross section

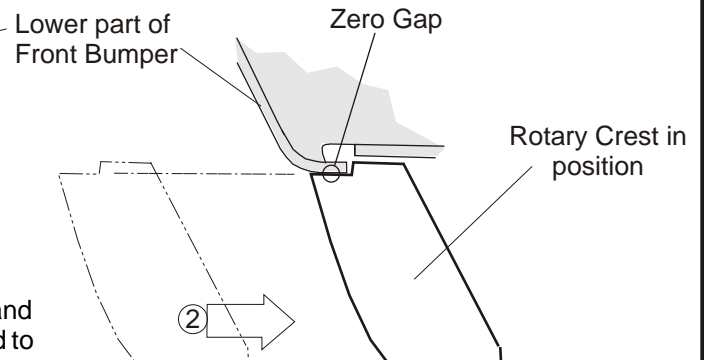

1. To minimize the Gap at the top between the Rotary Crest and bumper, pull firmly down on the lower bumper and proceed to step 2.

2. Insert the Rotary Crest making sure the top of the crest slides against the lower edge of the front bumper (as shown) to insure zero gap.

3. After the Rotary Crest is in place at its upper most position, release the Lower Bumper.

4. Press securely in place for about 30 seconds.

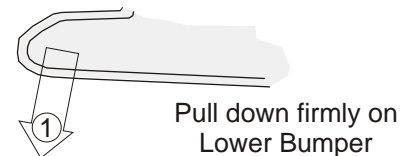

# 3 FINAL INSTALLATION

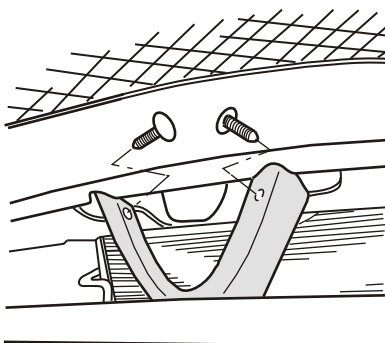

1. Completely insert the (2) fasteners into the holes of the Rotary Crest as shown.

2. With soft cloth and isopropyl (rubbing) alcohol , clean Front Bumper area free of any fingerprints.