

GENUINE

REAR UNDER DEFLECTOR



Using (Installation) Instructions

Thank you very much for buying the **Rear Under Deflector**.

To use it in its best conditions, you are expected to carefully read these using (installation) instructions for full understanding of the contents and to properly use it.

Please keep these instructions so that you can consult them every time you use the deflector.

Cautions and Requests

-  CAUTION and  WARNING marks shown in these instructions indicate safety precautions, which you are requested to strictly comply with during installation and use.
- Do not ever alter the product when installing it.
- Always avoid any installation and use that are not stated in these instructions.
- To avoid any improper installation, it is recommended to have the product installed at an exclusive Mazda dealer.
- Contact the dealer of your purchase for any further information you wish to know on the installation and use of the product and ensure you are in full understanding of the product before starting the installation or use.
- We may not accept the liability for any problems that might have occurred due to incompliance with these instructions.

1

PART NUMBER

F151 V4 930F

APPLICABLE MODEL

RX-8

※ Contact the dealer for applicable models or any other information.

Request

Please ensure that these using (installation) instructions be delivered to the customer.

F151 PK 934 2003-04

Mazda Motor Corporation

3-1, Shinch, Fuchu-cho, Aki-gun Hiroshima

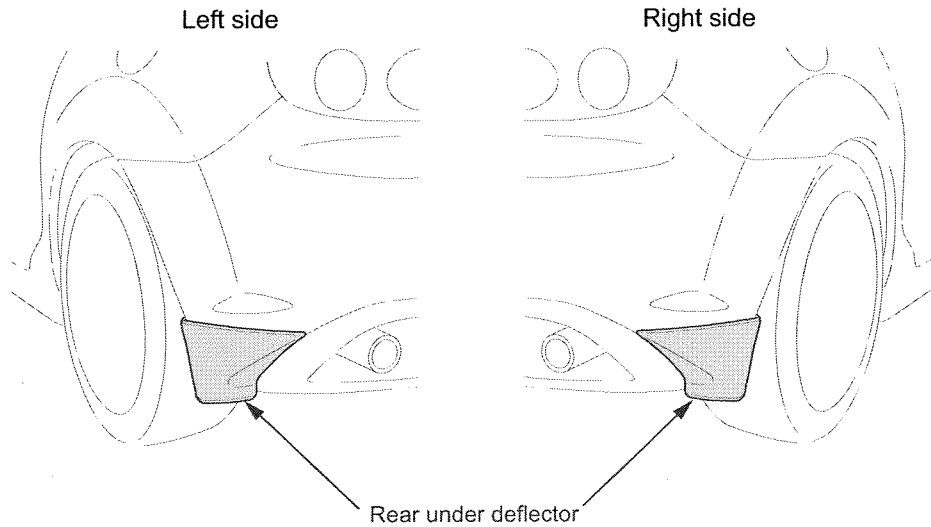
2**AS-COMPLETED VIEW****3****COMPONENTS****CAUTION**

Make sure that there is no missing component based on the following parts list and check the components for any dirt, scratches or other damage.

No.	Part name	Q'ty	Part number
①	Rear under deflector, RH	1	_____
②	Rear under deflector, LH	1	_____
③	Flange nut	2	99940 0502
④	Crocodile clip	2	GJ21 50 049
⑤	Clip nut	2	B092 51 861
⑥	Bolt	2	9YA01 0502
⑦	Using (installation) instructions	1	_____

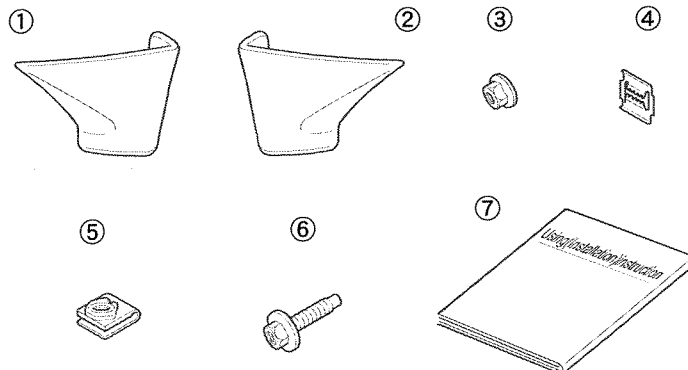

4

PREPARATORY WORK BEFORE INSTALLATION

Tools used (Have them ready at hand before starting the work.)

- ◆ Phillips-type screwdriver
- ◆ File
- ◆ Electric drill ($\phi 3\text{mm}$, $\phi 5\text{mm}$, $\phi 7\text{mm}$)
- ◆ Socket wrench and spanner (10mm), torque wrench (T20)
- ◆ Punch etc.
- ◆ Soft cloth (clean one)
- ◆ IPA (isopropyl alcohol) and white gasoline
- ◆ Plastic tape or equivalent
- ◆ Protective sheet
- ◆ Protective tape

CAUTION

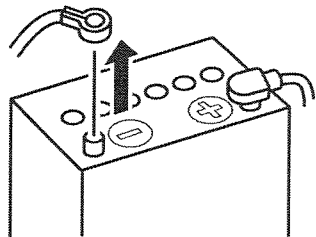
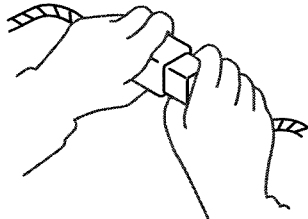
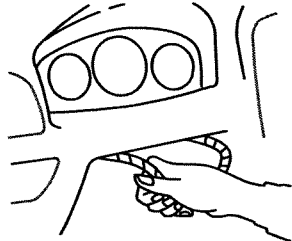
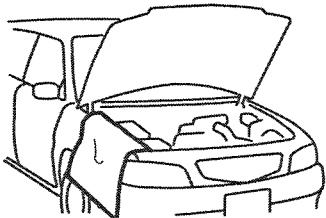
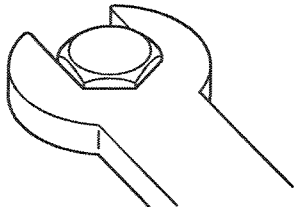
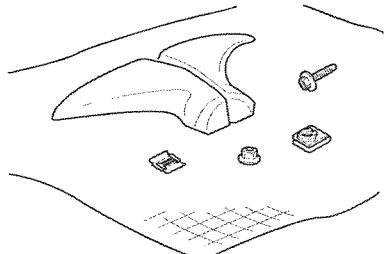
<p>Disconnect the negative terminal of the battery before doing the work.</p>	<p>Hold the connectors when disconnecting / connecting them to ensure the disconnection / connection.</p>	<p>Avoid exercising excessive force when pulling a wiring harness.</p>
		
<p>Use a mat or any other protective material when removing / installing components.</p>	<p>Use right tools appropriate for the purpose and size of the work to be done to ensure proper execution of the work.</p>	<p>Place the removed parts and components on a protective sheet or equivalent to avoid any damage on such parts/components.</p>
		

Note

- Consult the service manuals for the vehicle for the instructions on the removal and installation of the vehicle components.

CAUTION

- When the negative terminal of the battery gets disconnected, the memory of clock, radio and trip counter will be erased. Record the memory contents before starting the work.

WARNING

- Be sure to disconnect the negative battery cable before performing removal or installation procedure. Otherwise, serious injury or damage to the vehicle may occur.
- Always apply the parking brake before performing operations.

5

DISCONNECTING THE BATTERY TERMINAL

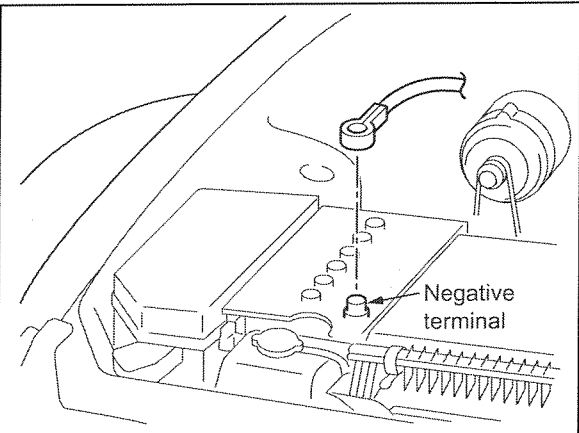
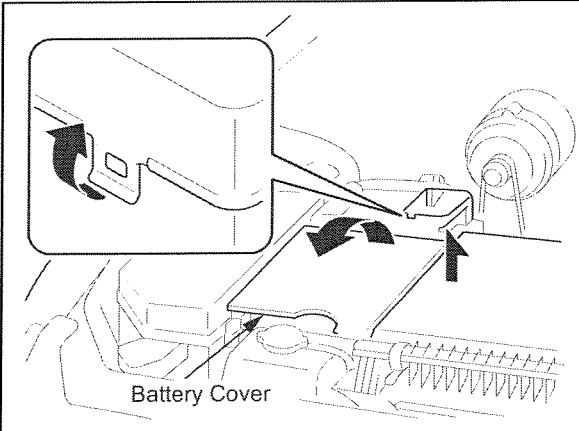
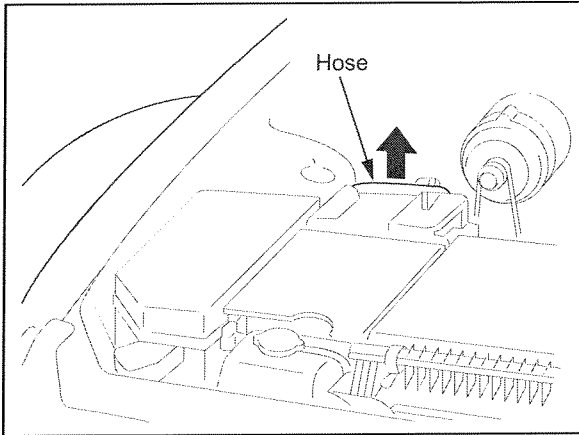
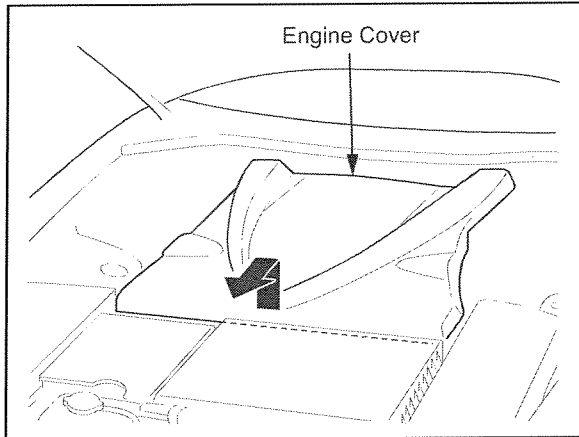

DISCONNECTING THE BATTERY TERMINAL

1. Make sure that headlamp, air conditioner and other devices are switched off.
2. Remove the engine cover.

3. Remove the hose from the battery cover.

4. Lift the battery cover from the rear to remove it.

5. Disconnect the negative terminal.



CAUTION

- When handling a battery, keep any source of fire away from it. Superheated gas from the battery may catch fire and may result in an explosion.

6

REMOVING THE VEHICLE COMPONENTS

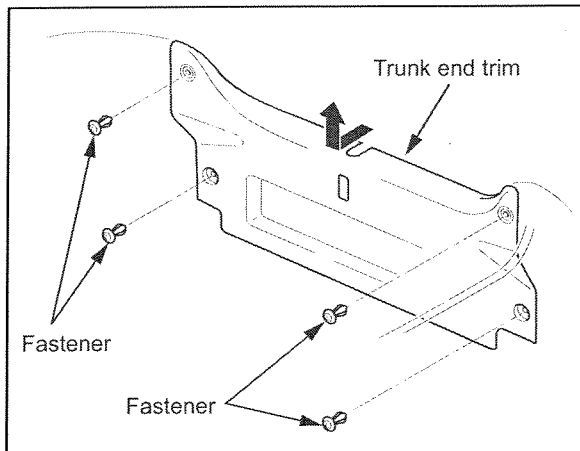

NOTE

- Since the removed components are to be reused when reassembling, keep them in a manner that will tell where to reinstall.

Removing rear combination lamp

1. Remove the fasteners that retain the trunk end trim to remove the trunk end trim.
2. Remove nuts that retain the rear combination lamp.
3. Disconnect the connector of the rear combination lamp from the socket.
4. Pull off the rear combination lamp in the direction of the arrow.

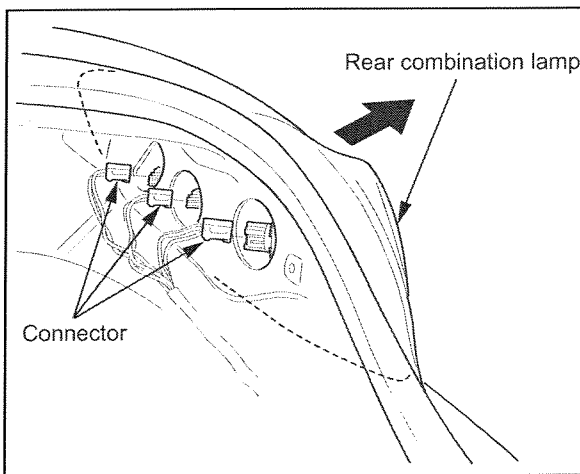

CAUTION

- Exercise sufficient care not to damage or lose the removed vehicle components.

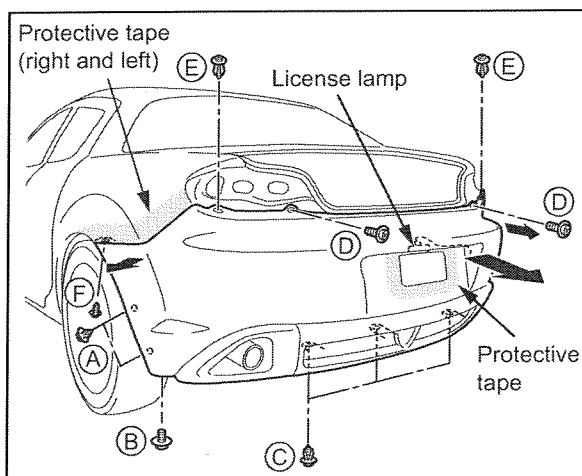

Removing rear bumper

1. Apply protective tape to protect the vehicle body against scratches.
2. Remove the fasteners retaining the mud guard and curl up the mud guard.
 - (A) Fastener (two for each of the left and right)
3. Remove components that retain the rear bumper.
 - (B) Bolt (lower part of the vehicle, one for each of the left and right)
 - (C) Fastener (lower part of the vehicle, three pieces)
 - (D) Screw (back of the rear combination lamp, one for each of the right and left)
 - (E) Fastener (upper part of the bumper, one for each of the right and left)
 - (F) Screw (on wheel arch, one for each of the right and left)
4. Disconnect the connector of the license lamp (inside the trunk compartment) from the socket.
5. Remove the rear bumper by sliding it rearward.

7

INSTALLING THE REAR UNDER DEFLECTOR

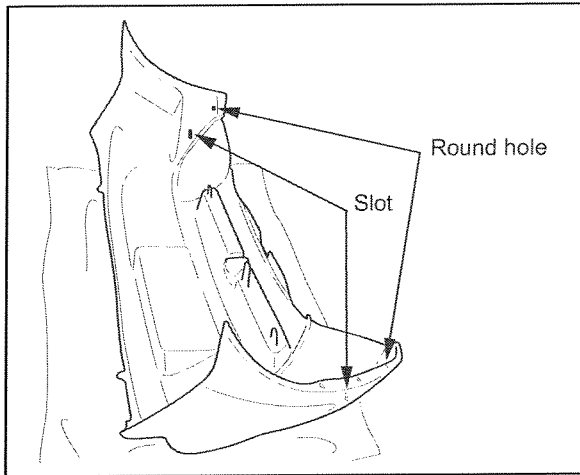

Perforation on the rear bumper

1. Place the rear bumper on protective sheet.
2. Perforate retaining holes as followings for the installation of the rear under reflector at the scribed positions of the rear bumper.

[Perforating round holes] · · · $\phi 7$ mm (at two locations)

Mark as by punching at the scribed center on the back of the front bumper. Bore a hole from the back of the bumper.

Perforate the hole using $\phi 3$ mm and $\phi 7$ mm drills successively.

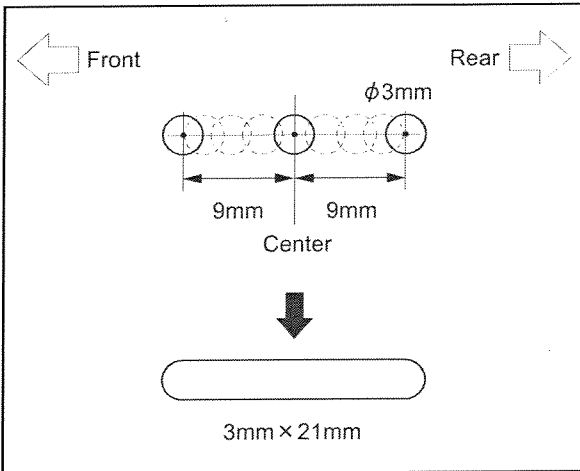

[Perforating slots] · · · 3mm x 21mm (at two locations)

Mark as by punching at the center of the scribed line on the back of the front bumper. Bore a $\phi 3$ mm hole at both ends of the marking-off from the back of the bumper.

Either bore several holes toward the center or use ultrasonic cutter to make a slot.

! WARNING

- Exercise sufficient care in handling drills and other cutting tools to avoid any personal injuries.
- To prevent any damage on the bumper and drilling through beyond the limit, always wrap the drill blade as with gum tape.

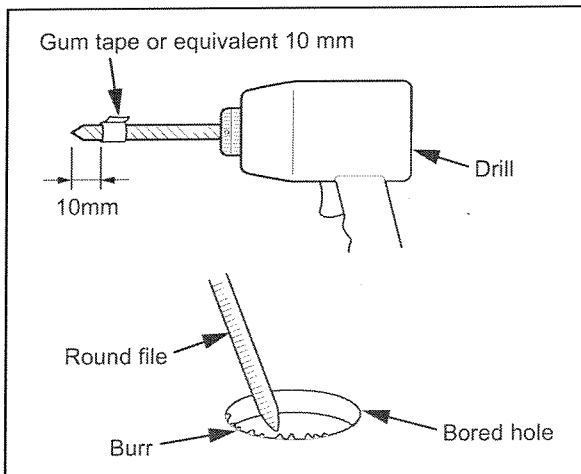

3. Remove burrs around the edge of the bore as with file.

! CAUTION

- When removing burrs, exercise care not to enlarge the hole diameter beyond the specification. Any incomppliance may cause the misalignment of the rear under reflector and other problems.

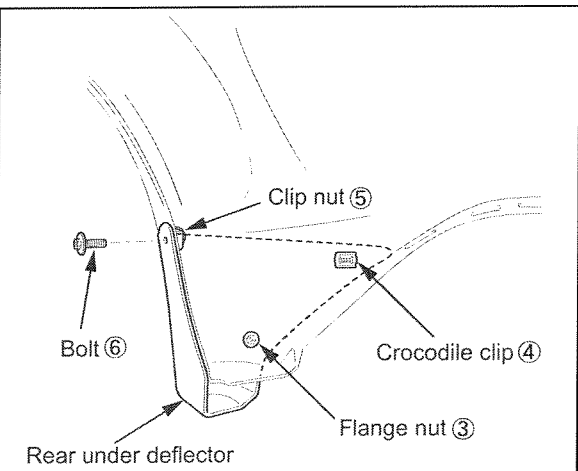
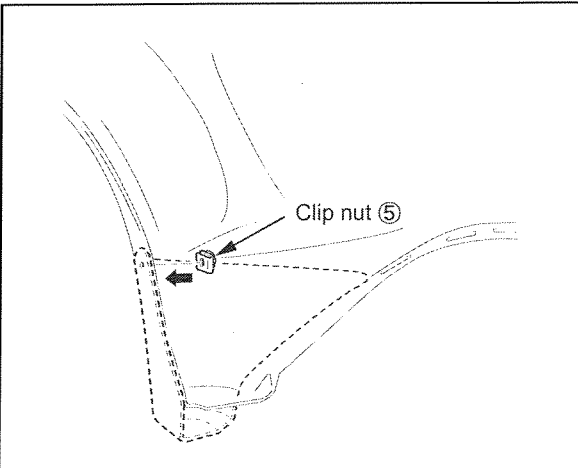
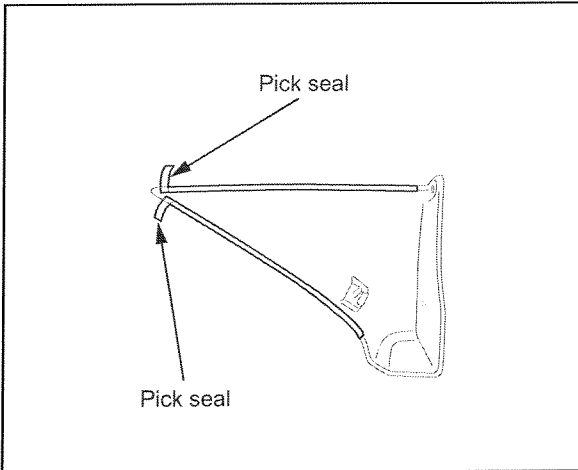
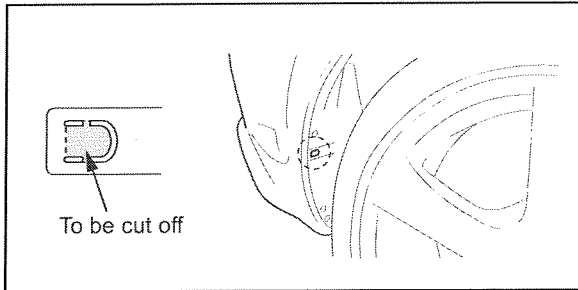

NOTE

- The figures are for the RH side. For LH side, perform the procedure in the same way as the RH.

Perforation on the mud guard

1. Bore retaining holes on the mud guard as with ultrasonic cutter. (one for each of the left and right)

Installing the rear under deflector

1. Bend the pick seals upward to facilitate peeling off. (at two points)

CAUTION

- Wipe as with isopropyl alcohol the rear bumper surface on which the rear under deflector is to be stuck to remove any grease and dirt.

2. Fit a clip nut (5) on the rear bumper.
3. Temporarily retain the rear under deflector onto the rear bumper as with bolt (6), flange nut (3) and crocodile clip (4).
4. Peel off the release-coated paper on the double-faced adhesive tape for the rear under deflector.

CAUTION

- Keep the rear under deflector slightly away from the rear bumper to prevent the release-coated paper from being torn.

5. Ensure the fit with the rear bumper and then press the rear under deflector at the section of the double-faced adhesive tape to get it stuck sufficiently.

CAUTION

- To ensure the fit with the rear bumper, pay particular attention to the corner rounds.
- Any peeling off of the product after getting it stuck will weaken the adhesive power. Avoid removing it once the press fitting has been completed.
- Avoid washing the vehicle (body) for 24 hours after the sticking.

6. Remove the temporarily fastened bolt (6) and fasten the flange nuts (3) and crocodile clips (4).

Tightening torque: 1.2-2.0 Nm

REINSTALLING THE VEHICLE COMPONENTS

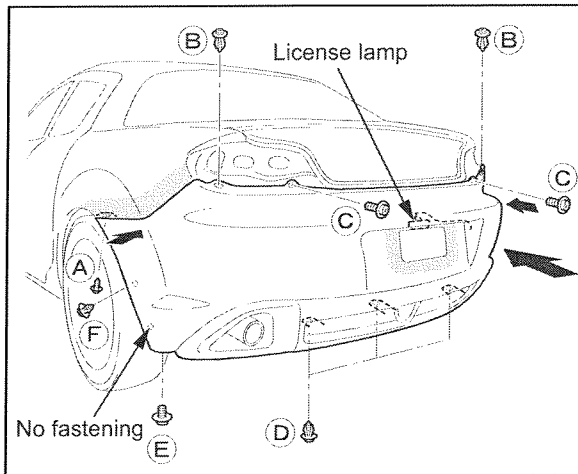

1. Once the rear under reflector has been installed, reinstall the bumper in the reverse order of removing it.

(A) Screw (wheel arch, one for each of the left and right); Tightening torque : 2.0-2.9 N•m

(B) Fastener (upper part of the bumper, one for each of the left and right)

(C) Screw (back of the rear combination lamp, one for each of the left and right);
Tightening torque : 1.0-1.5 N•m

(D) Fastener (lower part of the vehicle, three pieces)

(E) Bolt (lower part of the vehicle, one for each of the left and right) ; Tightening torque : 1.0-1.5 N•m

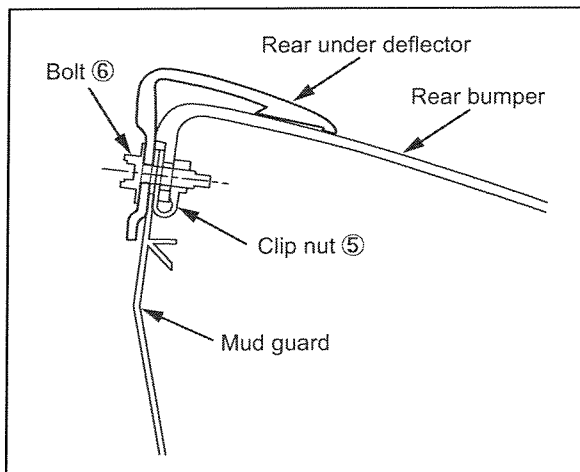

2. With the mud guard placed between the rear bumper and the rear under deflector, reinstall the mud guard using the fasteners that have been removed from the vehicle.

(F) Fastener (one for each of the left and right)

3. Fasten the rear under deflector with the clip nuts (5) mounted on the rear bumper and bolts (6).

(6) Bolt (one for each of the left and right);

Tightening torque : 6.8-9.8 N•m



CAUTION

- Please make fastening accurately.
- If you fasten with those torque other than specified, the front bumper might be broken or fallen off, therefore, please pay enough attention to make accurate fastening.

4. Reinstall the rear combination lamp in the reverse of the procedure for removing it.

5. Re-connect the negative terminal of the battery

**CAUTION**

If disconnected from the battery as during service, DSC will be disabled (which will be indicated by the flashing DSC OFF indicator light together with the illuminated TSC/DSC indicator light). To enable the DSC, carry out the following instructions:

1. Position the engine switch at ON.
2. Turn the steering wheel clockwise to its extreme and then counterclockwise again to its extreme.
3. Make sure that DSC OFF indicator light turns out.
4. Set the engine switch to the position OFF and then to ON again.
5. Check that TSC/DSC indicator light turns out.

If the TSC/DSC indicator light and DSC OFF indicator light will not turn out after turning the engine switch ON again, contact your Mazda dealer.

6. Reinstall the engine cover in the reverse of the procedure for removing it.

**CAUTION**

- When reinstalling the engine cover, make sure that the engine cover has been properly fitted.

== To the Customer: ==

**CAUTION**

Do not ever put your foot on any of the aero parts while the car is at rest. It will involve a risk to your safety.

On any significantly bumpy road, drive slowly and carefully. Otherwise, the retaining section may be damaged.

Installation Inspection Sheet

[To be used by installation workshop]

RX-8	REAR UNDER DEFLECTOR
	F151 V4 930F

Inspection items after completion of the work

- Inspect the installed parts and removed-and-reinstalled parts with respect to the following items.

Section to be inspected	Inspection item (circle)			
	Gap / fit & finish	Scratch, stain, tape residue	Tightening & engagement	Function
Rear under deflector (kit components)	<input type="radio"/>	<input type="radio"/>	<input type="radio"/>	
Rear combination lamp	<input type="radio"/>	<input type="radio"/>	<input type="radio"/>	<input type="radio"/>
License lamp		<input type="radio"/>	<input type="radio"/>	<input type="radio"/>
Rear bumper	<input type="radio"/>	<input type="radio"/>	<input type="radio"/>	
Rocker panel, side frame		<input type="radio"/>		

Rear under deflector installation inspection

Date		(year/month/day):			
VIN: No.					
Approved		Checked		Prepared	

※ Retention period of the sheet: 3 months