

Subject: ENGINE LACK OF POWER	Bulletin No: 01-014/08
	Last Issued: 12/26/2008

BULLETIN NOTE

- This bulletin supersedes the previous bulletin 01-014/08, issued 3/19/2008, 3/21/2008, 4/18/2008, 7/17/2008 and 10/24/2008. The REPAIR PROCEDURE has been revised.
- Warranty term coverage is 8 years (96 months) from the original warranty start date, with a 100,000 mile mileage limitation. Refer to WARRANTY INFORMATION for complete details.

APPLICABLE MODEL(S)/VINS

2004-2008 RX-8

DESCRIPTION

Some customers may experience a lack of engine power and an low engine idle speed during high ambient temperatures. This may be caused by poor sealing of rotor chambers due to an accumulation of carbon on the rotor housing trochoid surface. This is caused by a lack of metering oil lubrication during engine start or insufficient ignition timing under high ambient temperature conditions. A revised PCM calibration is available which increases metering oil lubrication amount during engine start. Ignition timing under high ambient temperature is recalibrated as well.

Customers who are currently experiencing a lack of engine power and low engine idle speed should have their vehicle repaired using the following repair procedure.

IMPORTANT:

- **BEFORE PERFORMING THE REPAIR PROCEDURE, ENSURE THE FOLLOWING ITEMS HAVE BEEN COMPLETED:**
 - **EMISSION RECALL 4206F**
 - **MAZDA SPECIAL PROGRAM (MSP16) – ENGINE LACK OF POWER**

REPAIR PROCEDURE

There are many possible concerns which may cause lack of power symptoms. The focus of this Service Bulletin is assisting diagnosis of concerns related to the Rotary Engine internal components. While it is impractical to list all possible causes in this Service Bulletin, please inspect the following common concerns which may cause lack of power symptoms before proceeding to "Engine Inspection".

- **CATALYTIC CONVERTER** - Restriction of the exhaust system due to catalyst failure may cause lack of power symptoms. Check MODE 6 ON BOARD TEST RESULTS and verify catalyst efficiency is within specification.
- **IGNITION COILS** - Non-functioning ignition coils may cause lack of power symptoms. Inspect ignition coils using Service Bulletin 01-016/07 "IGNITION COIL INSPECTION". Replace non-functioning ignition coils and test drive the vehicle to confirm lack of power symptom has been repaired.

Description	OBDMID	Test ID	Min	Max	Value
Catalyst Monitor Bank 1	21				
Rear-to-Front Switch Ratio	21	80	0:1	8:1	0.51:1

4206c

Is the measured test result “VALUE” number MORE or LESS than 4.60:1?

- **LESS THAN 4.60:1** - Catalytic converter OK, replacement is NOT necessary.
- **MORE THAN 4.60:1** - Catalytic converter failed, replace catalytic converter and check exhaust system for restriction by broken material. Test drive the vehicle to confirm lack of power symptom has been repaired.
- **SECONDARY SHUTTER VALVE (SSV)** - Lack of power may be caused by a stuck-closed Secondary Shutter Valve (SSV). This condition prevents intake airflow into the engine during mid and high RPM. Confirm the SSV moves freely and is not stuck in the closed position. The vehicle may also have P2070 (SSV stuck open) stored in PCM memory. Review Electronic Service Information for the latest Service Bulletins and / or consult workshop manual for current repair procedures.

Lack of power symptoms typically occur during hot ambient temperature conditions. Please perform the following engine diagnostics tests when the customer has a current lack of power complaint and / or during hot ambient temperatures for accurate results AFTER inspecting the above listed components.

- A - CARBON REMOVAL PROCEDURE
- B - TEST DRIVE
- C - ENGINE VACUUM VOLTAGE TEST

NOTE:

- Procedure C - ENGINE VACUUM VOLTAGE TEST will only be performed if instructed to in B - TEST DRIVE.

A - CARBON REMOVAL PROCEDURE

WARNING:

- PLEASE USE CAUTION WHEN USING ENGINE CLEANER.
- WEAR EYE PROTECTION AND GLOVES WHEN HANDLING ENGINE CLEANER.
- ENGINE CLEANER IS FLAMMABLE.

NOTE:

- An assistant may be necessary while performing this procedure.
 - Approximately half a can of engine cleaner will be used per vehicle during this repair.
1. Start engine and warm to operating temperature. Turn engine off.
 2. Cleaner kit comes with engine cleaner (A) and engine cleaner spray hose (B).

NOTE:

- Engine cleaner spray hose (B) is not used for this procedure and can be discarded.
- The can of engine cleaner (A) will have a red plastic spray tube attached to it. This red spray tube will be used for this procedure.

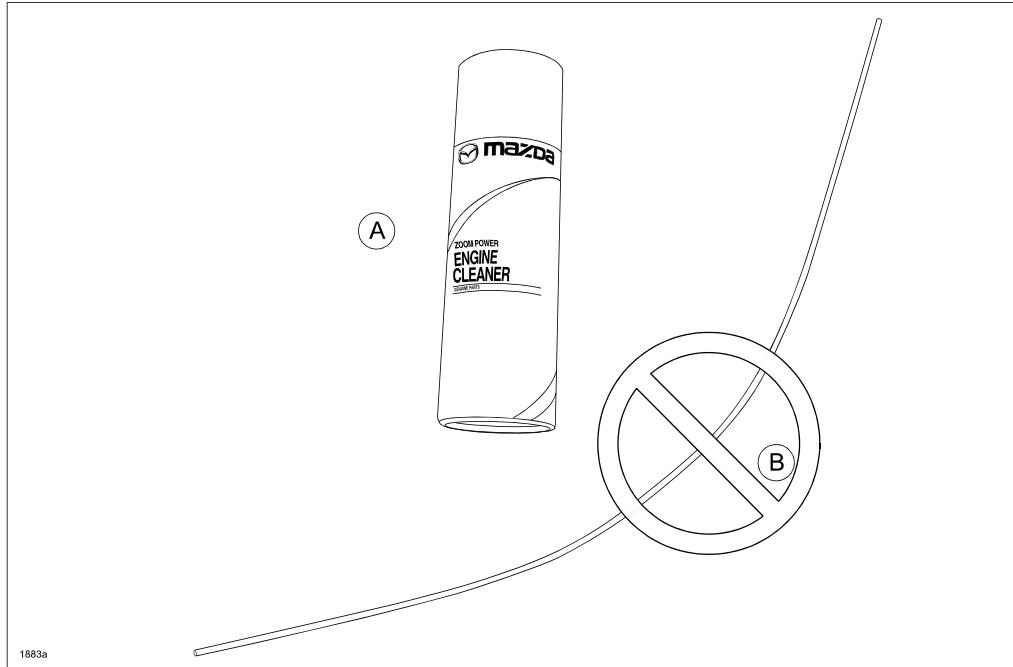

3. Cut a piece of electrical tape 2" (5cm) long and wrap around the end of the red spray tube.

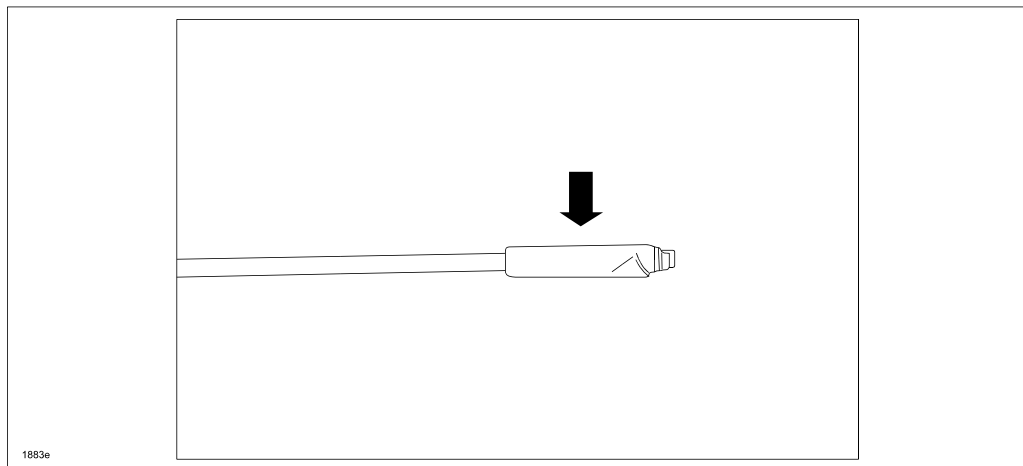

4. Cut a length of 1/8" inside diameter (ID) vacuum hose (obtained locally) to 27" (70cm). Insert tape wrapped end of red spray tube into vacuum hose and use a tie wrap to hold in place.

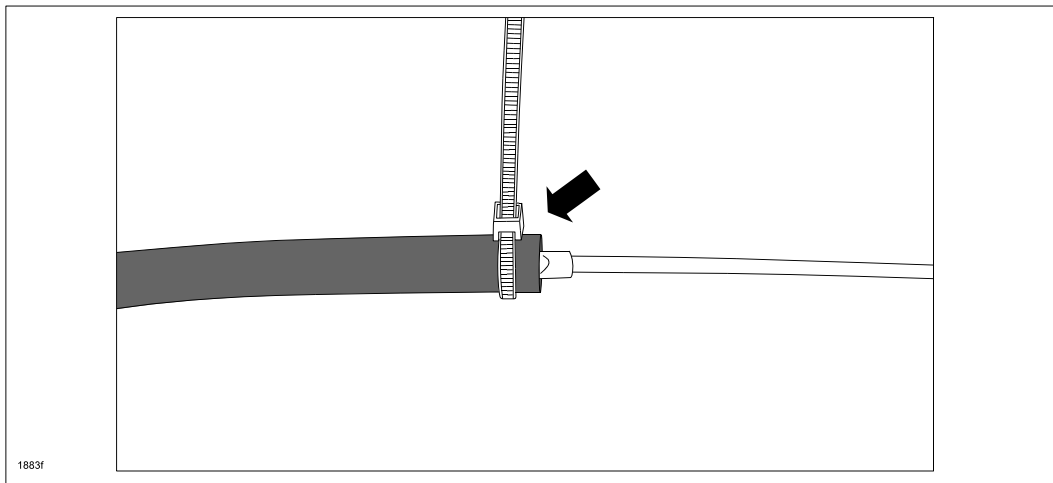

5. Disconnect Eccentric Shaft Position Sensor (ESPS) B1-27 connector.

NOTE:

- This will cut fuel injection and spark while performing the procedure.

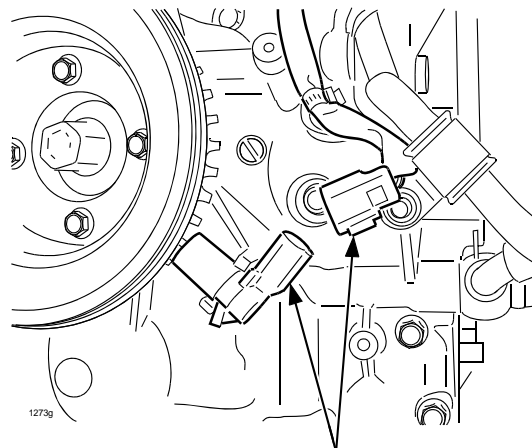

DISCONNECT ECCENTRIC
SHAFT POSITION SENSOR

6. Disconnect the secondary air injection pump connector B1-04.

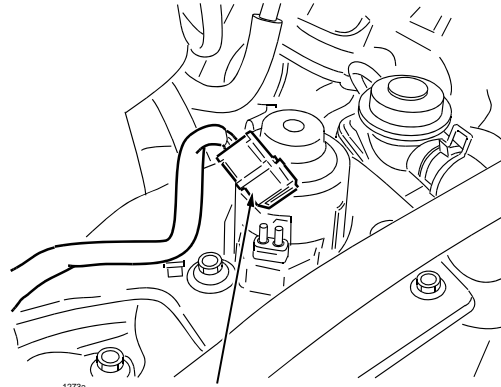

SECONDARY
AIR INJECTION PUMP
CONNECTOR (B1-04)

7. Remove the front vacuum plug or PCV vacuum hose from the passenger side of the lower intake manifold.

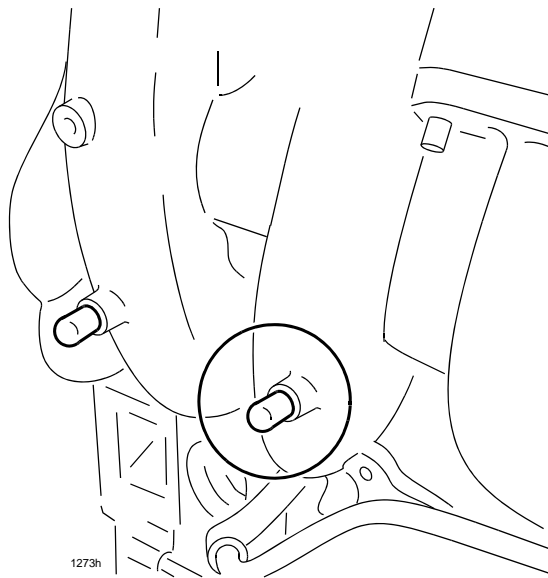

NOTE:

- 2006 model year and later vehicles have PCV vacuum hoses attached to these ports for the PCV system. Disconnect these hoses from the lower intake manifold ports one at a time when performing this procedure. These hoses do not need to be plugged once disconnected.

CAUTION:

- DO NOT attempt to service both vacuum ports at the same time. Perform the procedure for the front port, then perform the procedure for the rear port.

8. Attach the vacuum hose end into front port nipple.

NOTE:

- Ensure the vacuum hose is securely connected to the nipples to prevent the hose from becoming detached while spraying engine cleaner.

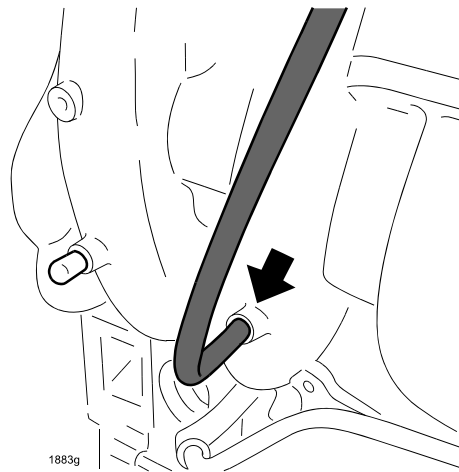

9. Attach the red spray hose end into the spray nozzle of the engine cleaner. Use care not to push down on the nozzle when inserting to prevent the can from spray cleaner.

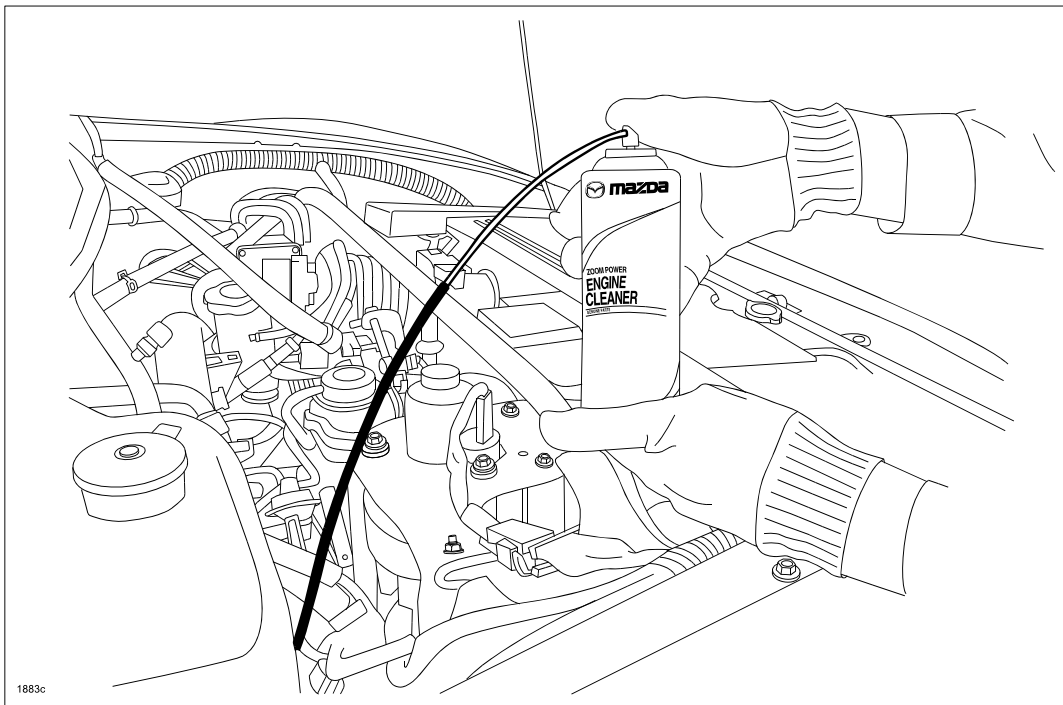

10. Have an assistant crank the engine. While cranking the engine, simultaneously depress the spray nozzle of the engine cleaner for a duration of 10 seconds. After 10 seconds, stop spraying and cranking at the same time. DO NOT depress accelerator pedal while cranking.
11. Wait a minimum of 30 seconds and repeat STEP 10 for the same port.
12. Remove the vacuum hose from the lower intake manifold nipple.
13. Reconnect PCV vacuum hose or install vacuum plug to front nipple.
14. Repeat STEPS 8-13 for rear nipple.
15. Allow the engine cleaner to soak for at least 1 hour before starting engine.
16. Connect ESPS connector B1-27.
17. Attempt to start engine without depressing accelerator pedal.
18. Keep engine running between 1500-2000 RPM until engine speed has stabilized. Maintain this engine speed until all smoke has dissipated and / or engine has come to full operating temperature.
CAUTION:
 - Do not race the engine during warm-up, this may cause catalyst damage.
19. Rev engine from idle speed up to 6,000 RPM, then release throttle immediately until RPM returns to idle speed.
20. Repeat 20 times with vehicle in Park (AT) or neutral (MT).
21. Connect M-MDS to vehicle and ID vehicle.
22. Using DATALOGGER, select MOP POS#
23. Perform METERING OIL PUMP (MOP) simulation test.

24. Using DATALOGGER, select MOP POS# and RPM.

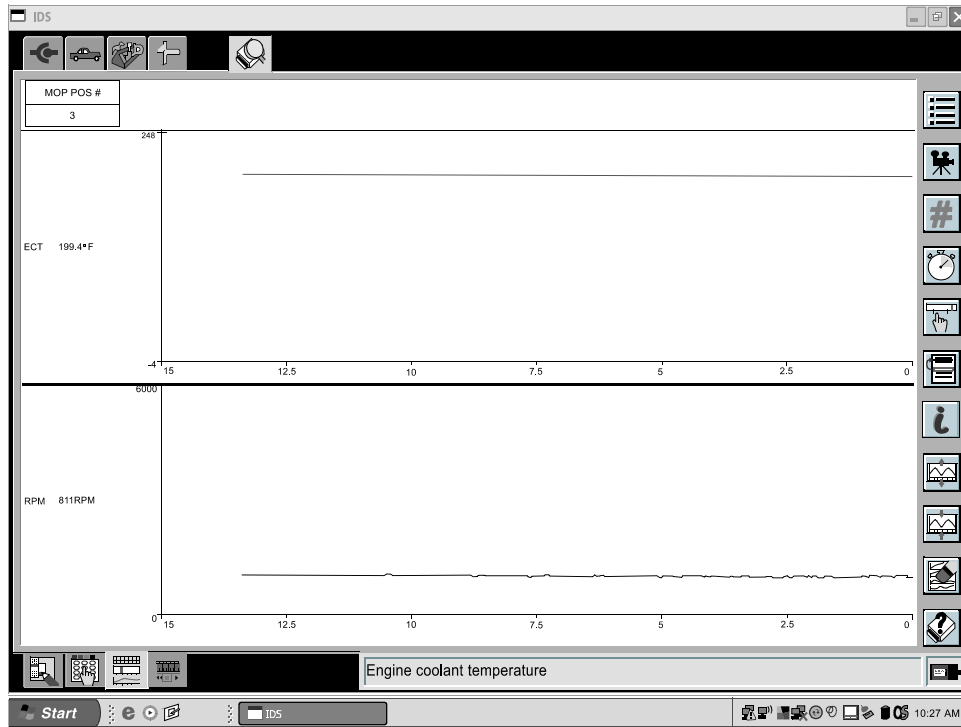

4206e

- A. Click on MOP POS# PID.
- B. Click on “#” symbol.
- C. Click “finger” symbol.

D. Click on "+ arrow up" symbol until MOP POS# indicates "60".

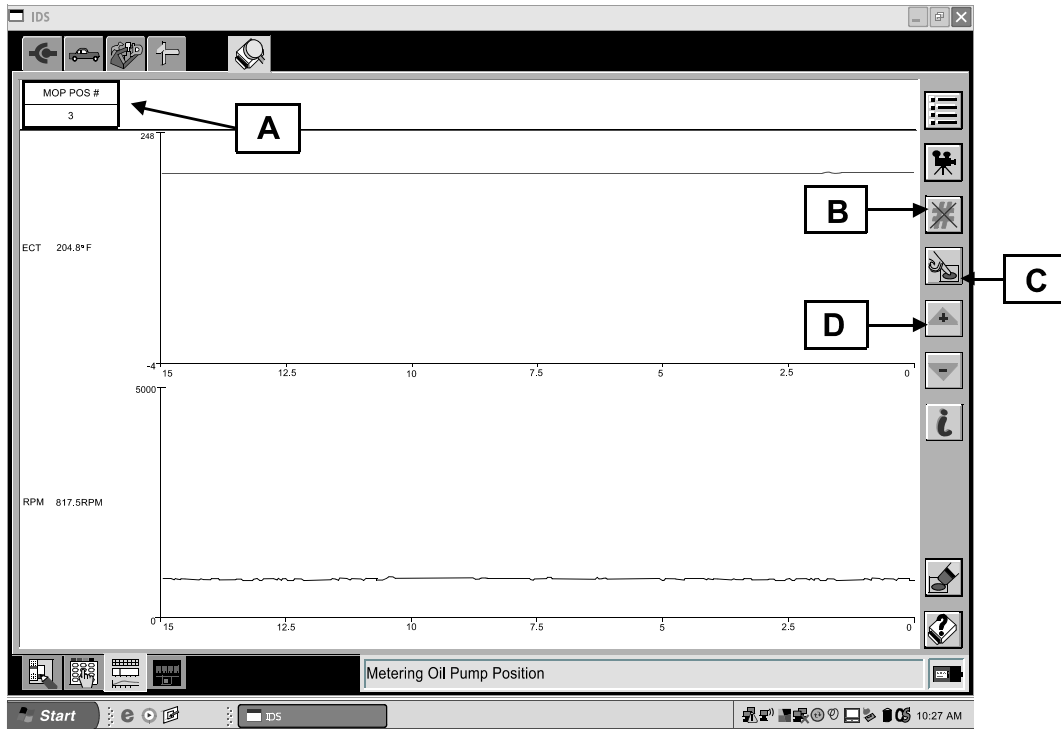

4206f

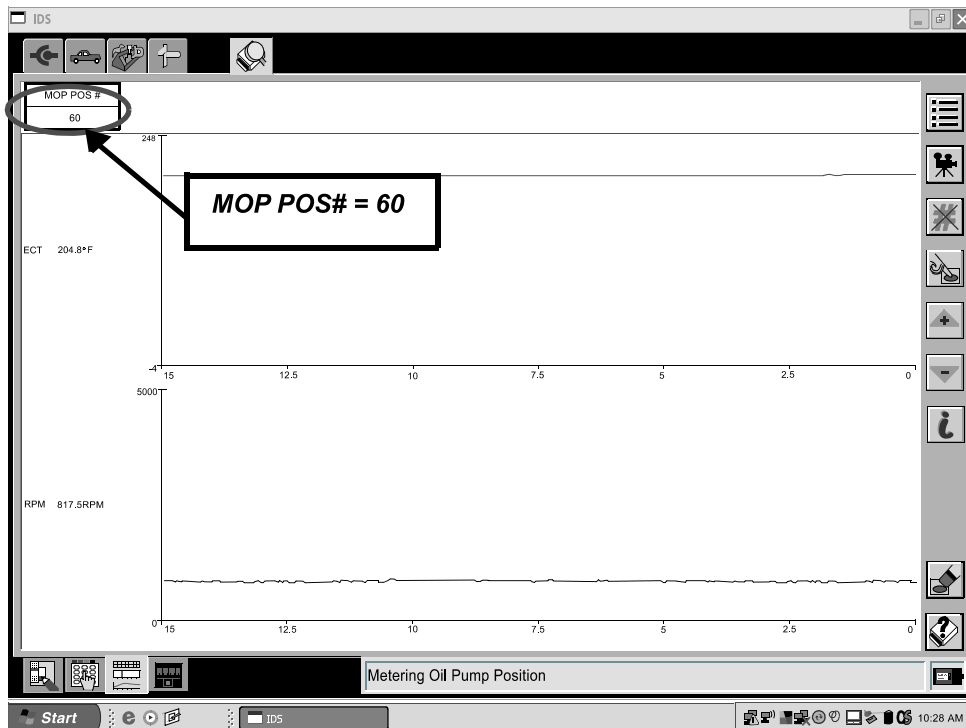

4206g

25. Allow engine to idle for 15 minutes with MOP POS # at step 60.

NOTE:

- Make sure transmission is in NEUTRAL or PARK and all loads OFF (AC, blower etc.), do not touch accelerator pedal during this time or test will abort.

26. Tap accelerator pedal after the 15 minutes have elapsed to abort test. MOP POS# will drop from step #60.

27. Turn engine off.

28. Connect the secondary air injection pump connector B1-04.

B - TEST DRIVE

1. Perform test drive lasting at least 40 minutes following these guidelines:

- Drive vehicle on city streets at speeds below 45 MPH.
- Air conditioning and fan speed on max.
- Accelerate at very light throttle keeping shift points below 3000 RPM.
- After 20 minutes stop vehicle in a parking lot, M/T in neutral and A/T in drive for one minute, and monitor engine RPM using the DATALOGGER PID.
- At the 40 minute mark, stop the vehicle in a parking lot, M/T in neutral and A/T in drive for one minute, and monitor engine RPM using the DATALOGGER PID.
- Safely accelerate the vehicle at wide open throttle (M/T shift at 8000 RPM) to the legal speed limit.

2. Did you experience any of the following during the test drive?

- The vehicle has a lack of power
- The RPM PID drops to below 700 RPM during the one minute stops.
 - **YES** - Engine replacement required, complete **ENGINE DIAGNOSTIC WORKSHEET (LACK OF POWER)** and refer to PARTS INFORMATION section for engine ordering process.
 - **NO** - Proceed to C - ENGINE VACUUM VOLTAGE TEST.

C - ENGINE VACUUM VOLTAGE TEST

NOTE:

- This test is ONLY necessary if the vehicle does not have any symptoms described in STEP 2 of B - TEST DRIVE.

IMPORTANT:

- This test must be performed immediately after test drive. The engine must be HOT for accurate results.

This test is performed using SST N3M1-18-791 (Manifold Vacuum Tester). You will also need to use FLUKE meter or equivalent to measure voltage.

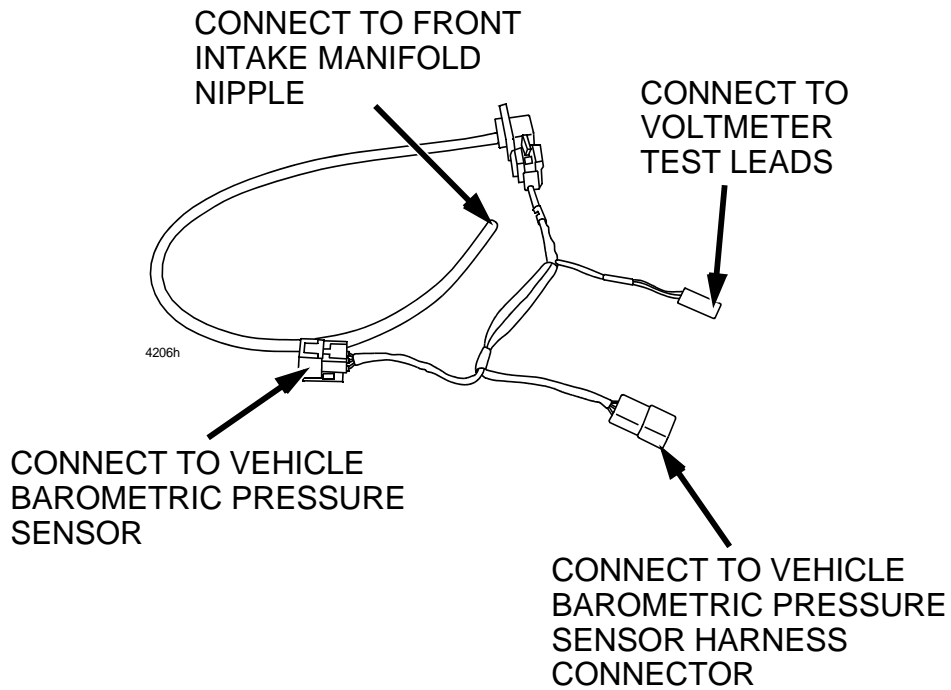

1. Remove the front vacuum plug or PCV vacuum hose from the passenger side of the lower intake manifold.

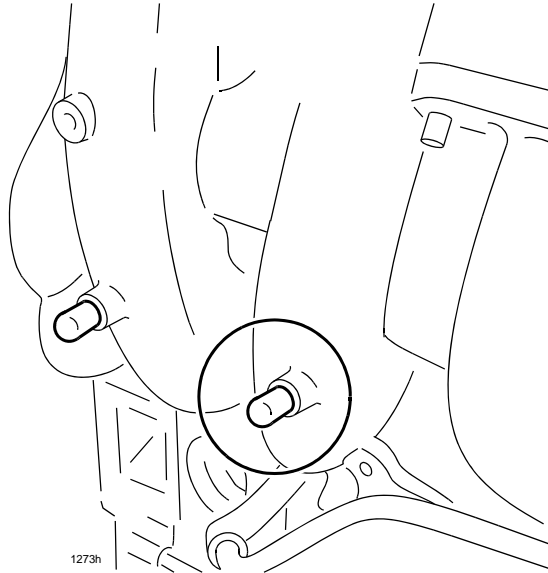

NOTE:

- 2006 model year and later vehicles have PCV vacuum hoses attached to these ports for the PCV system. Disconnect the front hose from the lower intake manifold port nipple and connect the Manifold Vacuum Tester. Plug the disconnected hose.

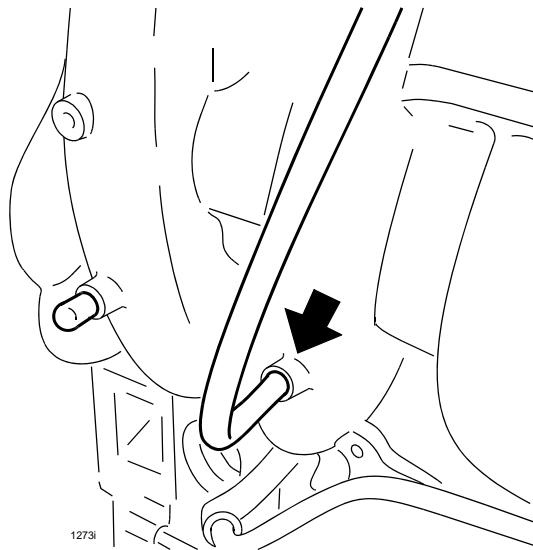

2. Attach vacuum hose of Manifold Vacuum Tester to intake manifold nipple.

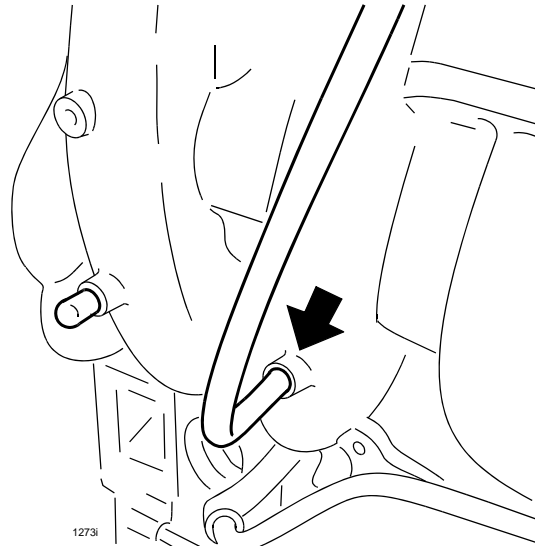

3. Disconnect vehicle barometric pressure sensor connector.

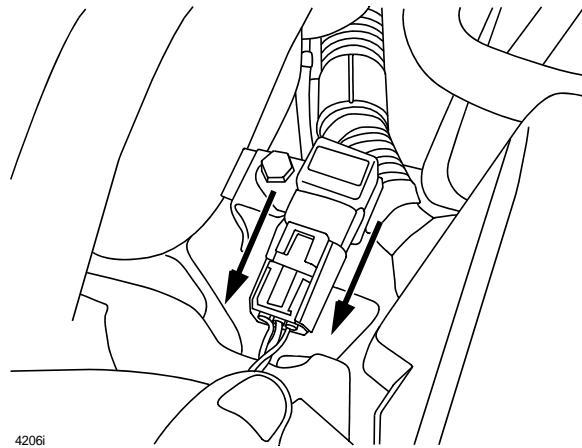

4. Connect SST to vehicle barometric pressure sensor and barometric pressure sensor connector.

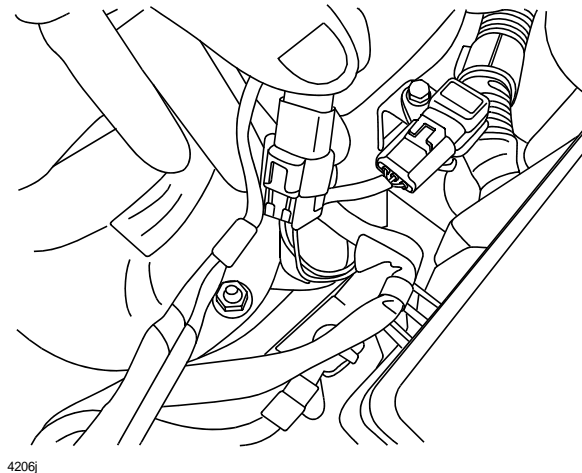

5. Connect positive lead of FLUKE meter to red wire of SST, and negative lead of FLUKE meter to black / green wire of SST.

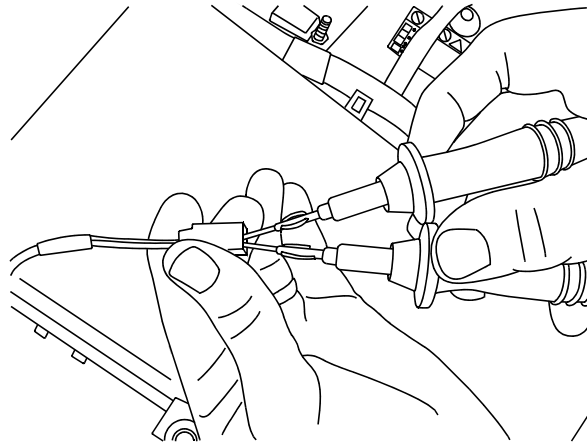

4206k

6. Turn ignition to "ON" position but do not start engine.
7. Using DC volt scale of FLUKE meter or equivalent, record voltage reading on the ENGINE DIAGNOSTIC WORKSHEET (LACK OF POWER) as "BARO" voltage.

NOTE:

- Make sure to document voltage reading EXACTLY as shown on the meter display to the "hundredth" position.
- **Voltage reading will vary depending on altitude of vehicle at time of testing.**

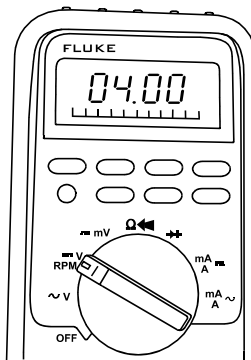

1924a

8. Start engine, idle for 5 minutes **with all loads OFF (air conditioning, lights, stereo, etc.) and transmission shift lever in PARK (AT) or NEUTRAL (MT).**

9. Record voltage reading on the attached **ENGINE DIAGNOSTIC WORKSHEET (LACK OF POWER)** as "IDLE" volt-age.

NOTE:

- Monitor voltage reading for 60 seconds and record lowest reading.
- Make sure to record the voltage reading **ONLY** when the engine cooling fans are OFF.
- Make sure to document voltage reading **EXACTLY** as shown on the meter display to the "hundredth" position.
- Voltage reading will vary depending on engine condition.

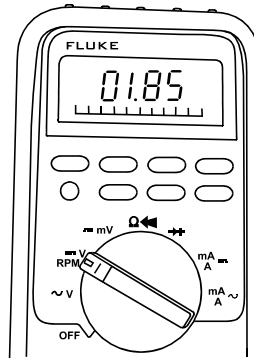

1924b

NOTE:

- Use the information from the **ENGINE DIAGNOSTIC WORKSHEET (LACK OF POWER)** to complete the MX Connect on-line diagnostic information required to determine engine replacement. After information has been entered into the on-line system, a message will be displayed informing you if engine replacement is necessary. If engine replacement is necessary, your order will be reviewed and e-mail confirmation of the engine parts order will be sent.

10. Verify repair.

ENGINE DIAGNOSTIC WORKSHEET (LACK OF POWER)

ENGINE DIAGNOSTIC WORKSHEET (LACK OF POWER)

**Use this form to fill in information on MX Connect website if it is
necessary to order an engine.**

Complete form only as directed by the repair instructions.

Log on to MX Connect.

- Click on "Parts and Accessories" located on the top menu bar.
- Under "Support" on the right side of the screen click on "RX-8 Recall 4206F and Service Bulletin Support".
- Click on "Lack of Power Engine Diagnostics".
- Fill in the required data using the information from this form. You will automatically be directed to the next item as the data is entered.

VIN

MILEAGE

1. Did you experience any of the following during test drive?

YES

NO

- a. Severe lack of engine power
- **YES, replace engine**
- **NO, go to 2**

- b. RPM PID drops below 700 during the 1 minute stops
- **YES, replace engine**
- **NO, go to 2**

2. Engine vacuum voltage test results

Engine vacuum voltage test results (necessary only if engine vacuum test was performed)

BARO Voltage

IDLE Voltage

PART(S) INFORMATION

NOTE:

- Enter data from ENGINE DIAGNOSTIC WORKSHEET (LACK OF POWER) form into “RX-8 Recall 4206F and Service Bulletin Support - Lack of Power Engine Diagnostics” under “Support” on the “Parts and Accessories” section of MX Connect. An engine will be automatically ordered if necessary.

Part Number	Description	Qty.	Notes
0000-77-A86	Engine Cleaner	1	Quantity 1 = 1 can of engine cleaner when ordered through eMDCS. 1 can of engine cleaner is sufficient for 2 engine cleanings.
N3M1-18-791	Manifold vacuum tester	0	This tool was shipped to your dealer for use with Emission Recall 4206F. Replacement tools may be ordered through M-Store.

WARRANTY INFORMATION

NOTE:

- This warranty information applies only to verified customer complaints on vehicles eligible for warranty repair.
- Warranty term coverage is 8 years (96 months) from the original warranty start date, with a 100,000 mile mileage limitation.
- Additional diagnostic time cannot be claimed for this repair.

	Repair procedure A + B	Repair procedure A + B + C
Warranty Type	A	A
Symptom Code	14	14
Damage Code	93	93
Part Number Main Cause	7777-02-006	7777-02-006
Part Number Main Cause Quantity	0	0
Related Part Number - Reimbursement Engine Cleaner	5555-08-008A Allowance applies to 1/2 can of engine cleaner per repair	5555-08-008A Allowance applies to 1/2 can of engine cleaner per repair
Related Part Number Quantity	1	1
Operation Number / Labor Hours:	XXD16XGX / 1.4 Hrs	XXD16AGX / 1.7 Hrs