

© 2009 Mazda Motor of America, Inc.

<b>Subject:</b> <b>SQUEAKING NOISE FROM UNDER DRIVER SEAT LIFTER LINK</b>	<b>Bulletin No:</b> 09-065/09
	<b>Last Issued:</b> 10/27/2009

## APPLICABLE MODEL(S) / VINS

- 2006-2010 MX-5
- 2004-2010 RX-8
- 2004-2010 MAZDA3
- 2006-2010 MAZDA5
- 2003-2010 MAZDA6
- 2007-2010 CX-7
- 2007-2010 CX-9

## DESCRIPTION

Some vehicles may exhibit a squeaking noise coming from under the driver seat when entering, exiting the vehicle or while driving the vehicle around a corner.

Customers having these concerns should have their vehicle repaired using the following repair procedure.

**CONSUMER NOTICE:** The information and instructions in this bulletin are intended for use by skilled technicians. Mazda technicians utilize the proper tools/equipment and take training to correctly and safely maintain Mazda vehicles. These instructions should not be performed by "do-it-yourselfers." Customers should not assume this bulletin applies to their vehicle or that their vehicle will develop the described concern. To determine if the information applies, customers should contact their nearest authorized Mazda dealership. Mazda North American Operations reserves the right to alter the specifications and contents of this bulletin without obligation or advance notice. All rights reserved. No part of this bulletin may be reproduced in any form or by any means, electronic or mechanical---including photocopying and recording and the use of any kind of information storage and retrieval system ---without permission in writing.

## REPAIR PROCEDURE

1. Verify customer complaint.
2. Position the seat lifter to highest position.
3. Remove the seat assembly according to the appropriate MS3 online instructions or Workshop Manual.
4. Place the seat on its side on a clean surface.
5. Apply Molybdenum spray grease (B) between the shaft (A) and side frame (C).

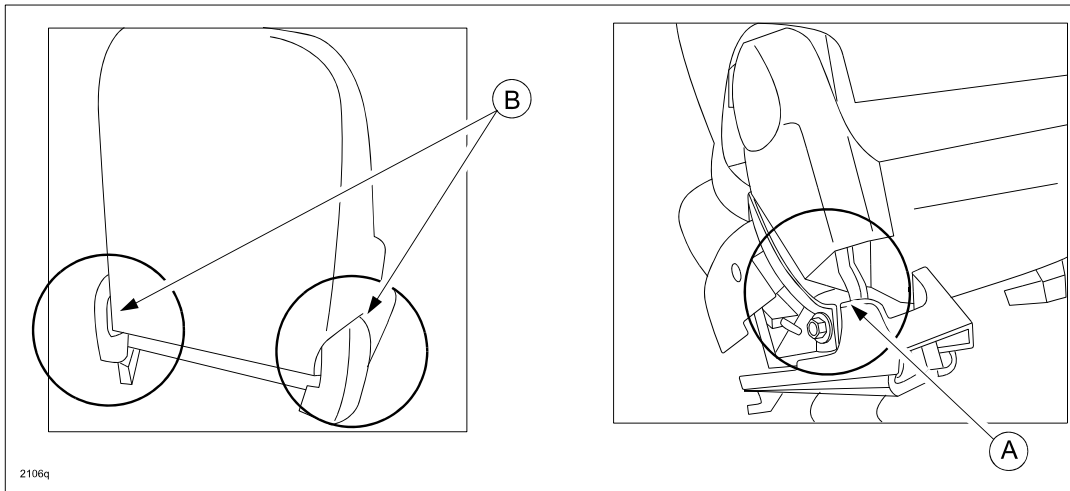

**NOTE:** Be sure to apply the spray grease to both sides.

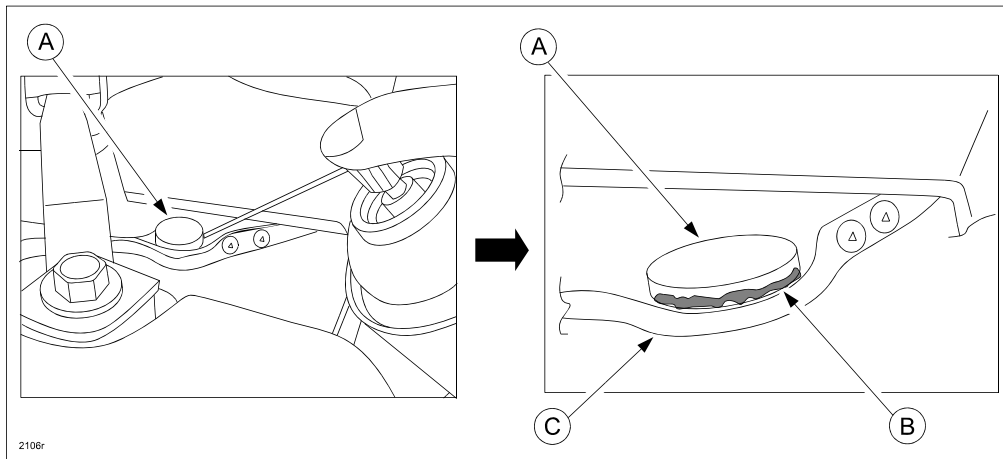

6. Reinstall the driver seat.
7. Operate the seat lifter several times in order to spread the grease.
8. Verify repair.

## WARRANTY INFORMATION

**NOTE:**

- This warranty information applies only to verified customer complaints on vehicles eligible for warranty repair.
- This repair will be covered under Mazda's New Vehicle Limited Warranty term.
- Additional diagnostic time cannot be claimed for this repair.

Warranty Type	A
Symptom Code	82
Damage Code	9H
Part Number Main Cause	7777-NS-ST6
Quantity	0
Operation Number / Labor Hours:	S0901ARX / Refer to SRT manual - "Front Seat Assembly - One side" (Grease application)