

© 2009 Mazda Motor of America, Inc.

Subject: CHATTERING NOISE / UNABLE TO ADJUST DRIVER-SIDE MANUAL SEAT LIFT	Bulletin No: 09-059/09
	Last Issued: 10/23/2009

BULLETIN NOTE

- This bulletin supersedes the previous bulletin 09-039/07 issued 11/21/07. The SUBJECT, APPLICABLE MODEL(S) / VINS and DECSRIPTION have been revised.
- Changes are noted below in Red beside the change bar.

APPLICABLE MODEL(S)/VINS

2004-2010 Mazda3
2006-2010 Mazda5
2003-2010 Mazda6
2007-2010 CX-7
2007-2010 CX-9
2004-2010 RX-8

DESCRIPTION

Some vehicles may exhibit a chattering noise and the driver-side seat lift cannot be adjusted because the lock plate guide comes off the guide cam when operating the lift. If the lift lever is then operated with the lock plate guide off, the guide cam can be damaged. The shape of both ends of the guide cam has now been changed to stop the lock plate guide from coming off.

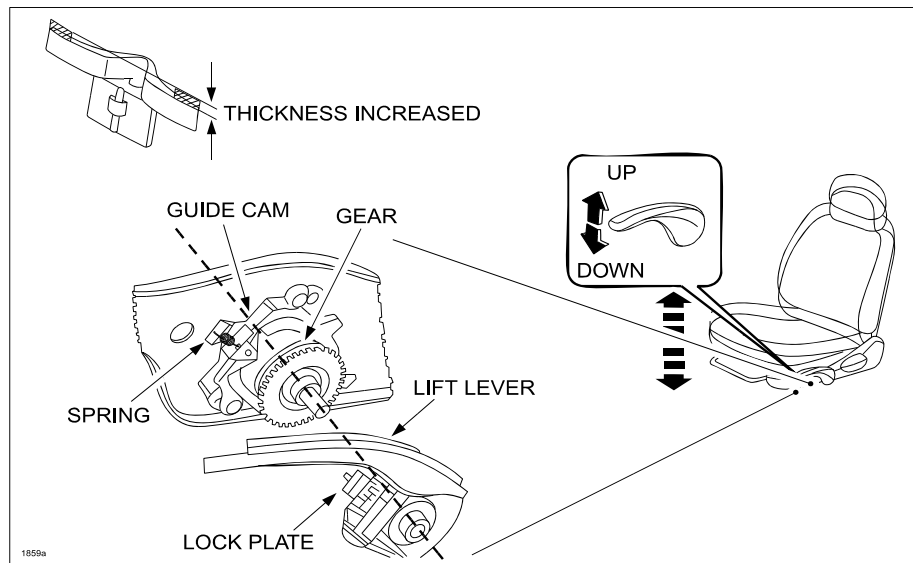

Customers having this concern should have their vehicle repaired using the following repair procedure.

CONSUMER NOTICE: The information and instructions in this bulletin are intended for use by skilled technicians. Mazda technicians utilize the proper tools/equipment and take training to correctly and safely maintain Mazda vehicles. These instructions should not be performed by "do-it-yourselfers." Customers should not assume this bulletin applies to their vehicle or that their vehicle will develop the described concern. To determine if the information applies, customers should contact their nearest authorized Mazda dealership. Mazda North American Operations reserves the right to alter the specifications and contents of this bulletin without obligation or advance notice. All rights reserved. No part of this bulletin may be reproduced in any form or by any means, electronic or mechanical---including photocopying and recording and the use of any kind of information storage and retrieval system ---without permission in writing.

REPAIR PROCEDURE

1. Verify customer concern.
2. Remove the lift lever outer cover by releasing the tab as shown, then sliding the cover forward.

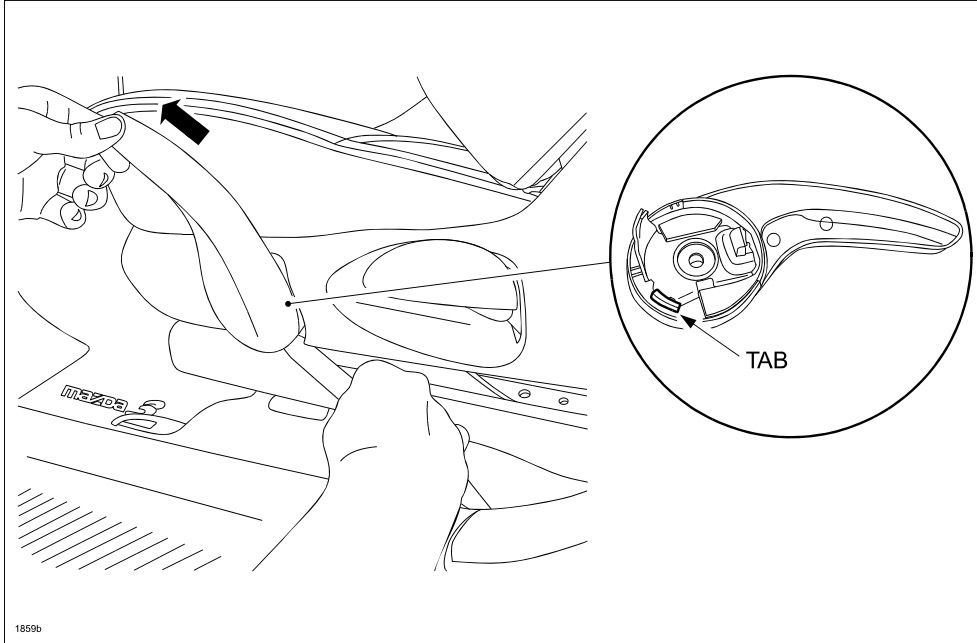

3. Remove the recline lever cover by lifting the lever up and pulling, then remove the side cover screw.

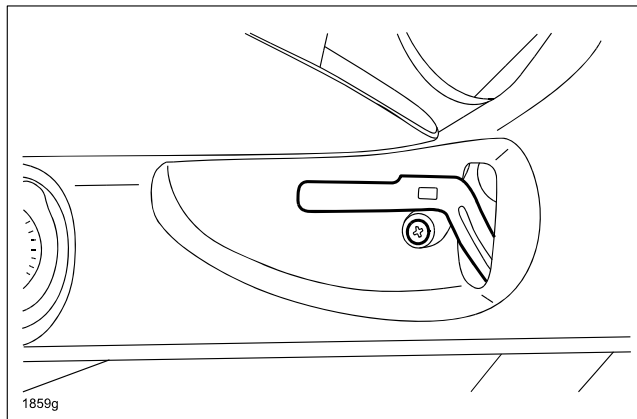

4. Remove the lift lever.

NOTE: Be sure to remove the lift lever and inner cover as an assembly.

a. Remove the snap ring.

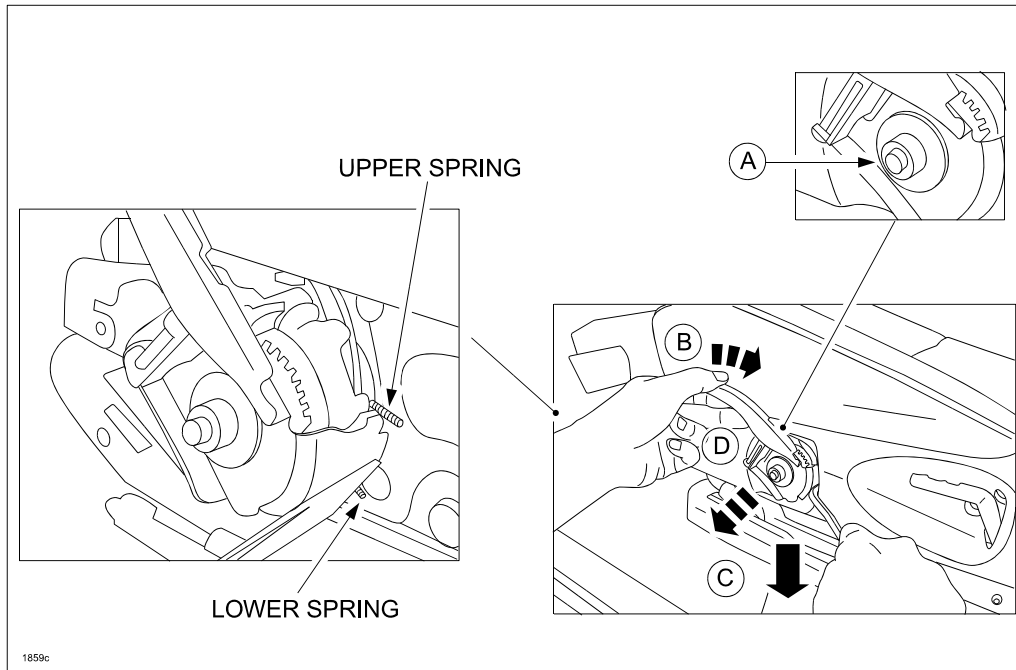

b. Pull the lift lever upward and hold it up.

c. Using a flat blade screwdriver, push down on the lower spring through the opening in the side cover.

NOTE: Be careful not to damage the side cover.

d. Pull the lift lever outward to remove it from the shaft.

5. Release the engagement of the front side hooks of the side cover by pushing the side cover back from the front, then pulling out.

NOTE: The side cover does not have to be removed completely, just release the front portion from the seat.

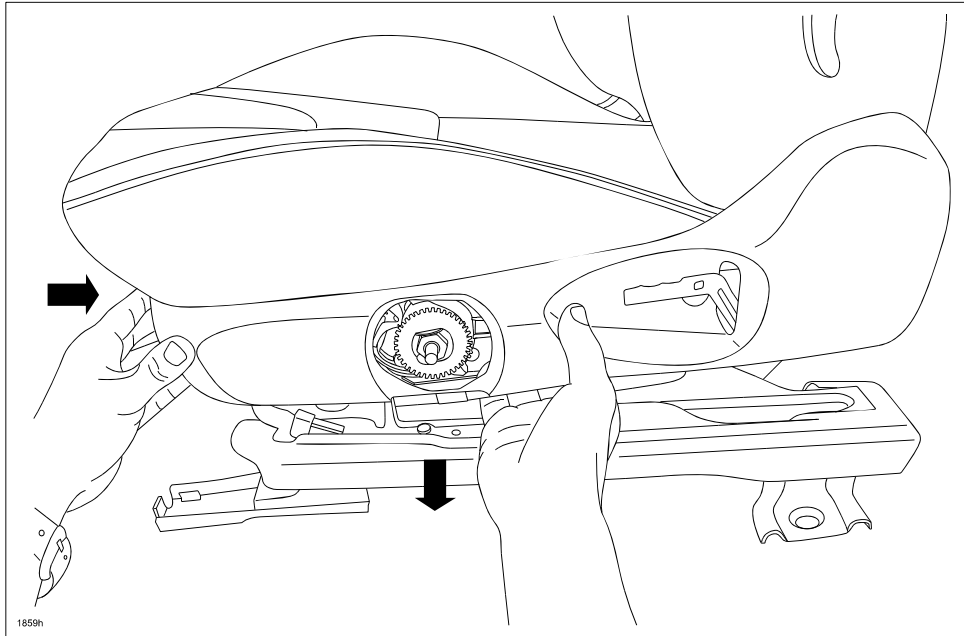

6. Replace the guide cam and spring with modified ones.
 - a. Remove the spring and pull the guide cam outward to remove it from the shaft.

NOTE: Perform the repair through the opening in the side cover.

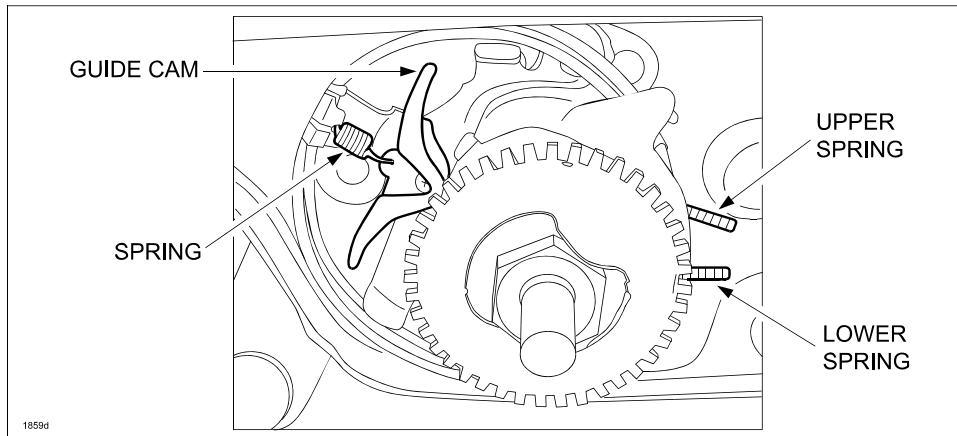

- b. Apply grease to the guide cam shaft and the contact surfaces of the guide cam and lock plate hook by reusing grease from the old part.
 - c. Replace the guide cam and spring with the modified ones.

7. Reinstall the lift lever.

- a. Hold the moving part of the lock plate with finger, then flip up the hook.
- b. Align the notch on the lift lever with the spring location on the lifter, then insert.

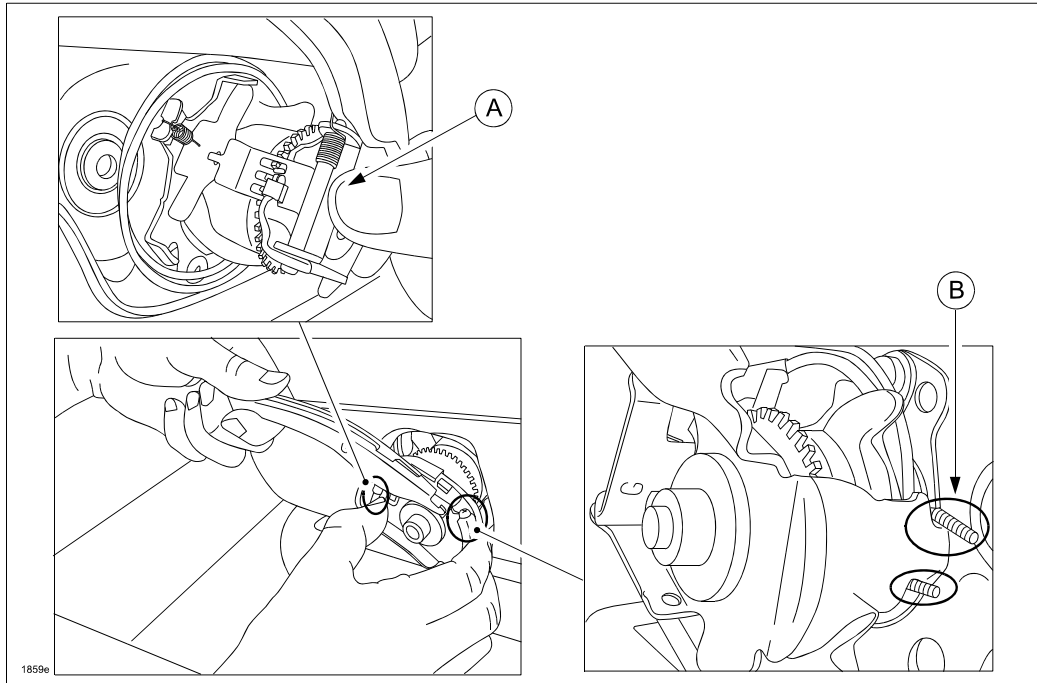

- c. Release finger from the moving part of the lock plate, then flip down the hook and allow it to engage with the gear.
- d. Make sure that the hook (convex) of the lock plate is fitted into the guide cam (concave).

NOTE: If the hook and guide cam are not fitted properly and the lift is operated, the guide cam will be damaged.

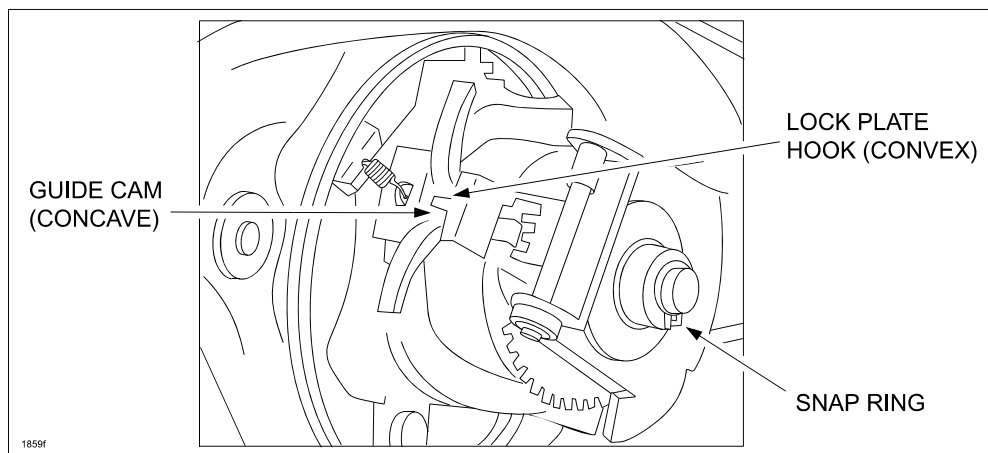

- e. Install a new snap ring.

NOTE: Make sure the snap ring is fitted in the groove securely.

8. Reinstall the side cover and recline lever cover.
9. Reinstall the lift lever outer cover.
10. Verify repair.

PART(S) INFORMATION

Part Number	Description	Qty.
C243-88-684	Guide Cam	1
C243-88-015	Spring	1
GJ6A-88-098	Snap Ring	1

WARRANTY INFORMATION

NOTE:

- This warranty information applies only to verified customer complaints on vehicles eligible for warranty repair.
- This repair will be covered under Mazda's New Vehicle Limited Warranty term.
- Additional diagnostic time cannot be claimed for this repair.

Warranty Type	A
Symptom Code	91
Damage Code	97
Part Number Main Cause	C243-88-684 (Guide Cam)
Quantity	1
Operation Number / Labor Hours:	XXC1MXRX / 0.3 Hrs.