

© 2007 Mazda Motor of America, Inc.

Subject: SUNVISOR PIVOT BROKEN	Bulletin No: 09-002/07
	Last Issued: 2/2/2007

APPLICABLE MODEL(S)/VINS

2004-2005 RX-8

2006 RX-8 with VIN lower than JM1 FE**** ** 207643 (built prior to July 7, 2006)

DESCRIPTION

Some customers may experience the sunvisor broken at the pivot area and the upper and lower parts of sunvisor are split.

Customers having this concern should have their vehicle repaired using the following repair procedure.

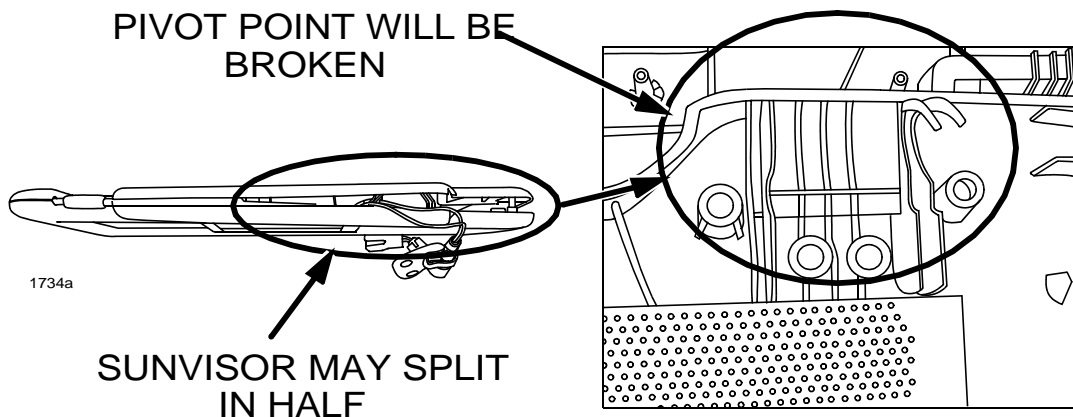

REPAIR PROCEDURE

1. Verify customer concern.
2. Replace the sunvisor with modified part(s). Refer to Workshop Manual section 09-17 SUNVISOR REMOVAL / INSTALLATION.
3. Verify repair.

Bulletin No: 09-002/07 © 2007 Mazda Motor of America, Inc.	Last Issued: 2/2/2007
--	------------------------------

PART(S) INFORMATION

Part Number	Description	Qty.	Notes
FE01-69-270E-77	Sun Visor (Passenger's Side)	1	2004-2005
FE01-69-320E-77	Sun Visor (Driver's Side)	1	2004-2005
FE88-69-270-77	Sun Visor (Passenger's Side)	1	2006 up to July 7, 2006 production up to VIN 207643
FE88-69-320-77	Sun Visor (Driver's Side)	1	2006 up to July 7, 2006 production up to VIN 207643

WARRANTY INFORMATION

NOTE:

- This warranty information applies only to verified customer complaints on vehicles eligible for warranty repair. Refer to the Warranty Wizard for warranty term information.
- Additional diagnostic time cannot be claimed for this repair.

Warranty Type	A
Symptom Code	92
Damage Code	9A
Part Number Main Cause	SEE PART(S) INFORMATION
Quantity	1
Operation Number / Labor Hours:	XXB464RX / 0.2 Hrs. (One or both sides)