

Subject: FRONT LICENSE PLATE FRAME MOUNTING INSTRUCTIONS - SERVICE TIP	Bulletin No: 09-015/03
	Last Issued: 9/22/2003

APPLICABLE MODEL(S)/VINS

RX-8

DESCRIPTION

This bulletin describes PDI (Pre -Delivery Inspection) front license plate holder installation.

REPAIR PROCEDURE

1. Find the dimples which locate the hidden nut locations.
 - Drill 8mm holes through the dimples to reveal the hidden nuts {depth no more than 6.0mm (0.25 inch)}.

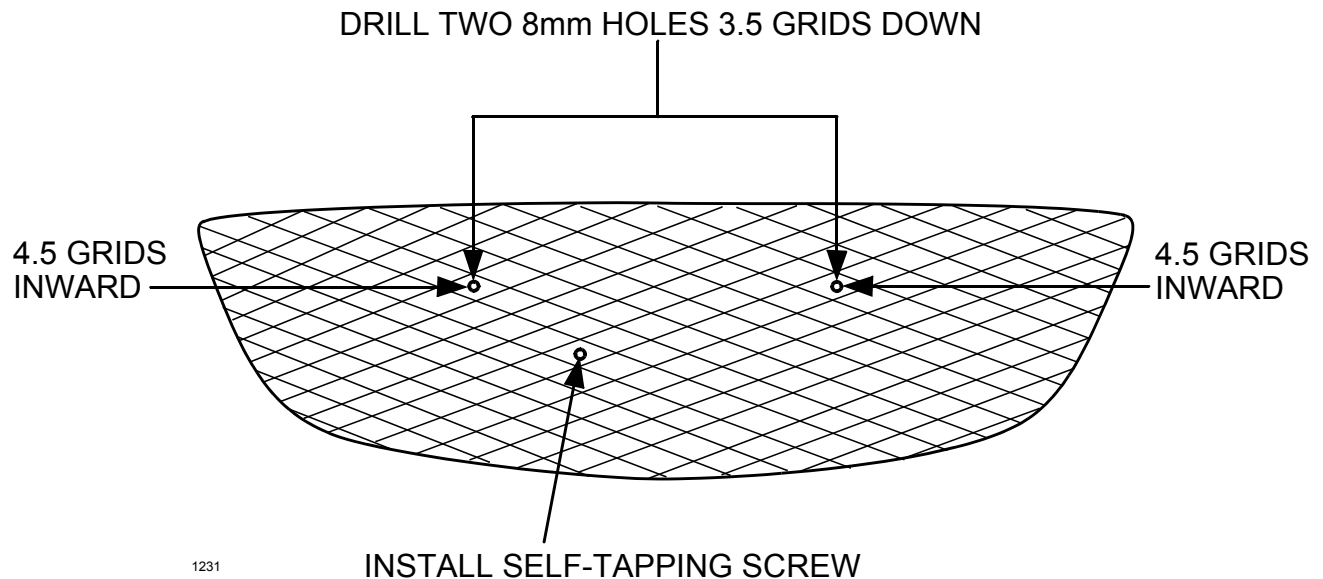

2. Align the license plate frame with the upper bolt holes and attach it with two-8mm bolts.
3. Install a self tapping screw on the lower left hole of the license plate frame.

CONSUMER NOTICE: The information and instructions in this bulletin are intended for use by skilled technicians. Mazda technicians utilize the proper tools/equipment and take training to correctly and safely maintain Mazda vehicles. These instructions should not be performed by "do-it-yourselfers." Customers should not assume this bulletin applies to their vehicle or that their vehicle will develop the described concern. To determine if the information applies, customers should contact their nearest authorized Mazda dealership. Mazda North American Operations reserves the right to alter the specifications and contents of this bulletin without obligation or advance notice. All rights reserved. No part of this bulletin may be reproduced in any form or by any means, electronic or mechanical--including photocopying and recording and the use of any kind of information storage and retrieval system ---without permission in writing.