

| | |
|---|--------------------------------|
| Subject: ENGINE CRANKS NO START | Bulletin No: 01-013/12 |
| | Last Issued: 02/29/2012 |

BULLETIN NOTE

- This bulletin supersedes the previous bulletin 01-021/10, issued on 04/01/10. The APPLICABLE MODEL(S)/VINS and PART(S) INFORMATION have been revised.
- Changes are noted below in Red beside the change bar.

APPLICABLE MODEL(S) / VINS

2009-2011 RX-8

DESCRIPTION

Some vehicles may experience difficulty starting (cranks no start).

A cranks, no start condition may occur after driving the vehicle a short distance without engine reaching normal operating temperature. Examples: starting a vehicle and moving it to wash it, engine stall due to mis-application of clutch then restart. This commonly occurs at port facilities or dealer lots where vehicles are frequently started cold, moved for short distances and then turned off.

A cranks, no start condition may be caused either by fuel flooded spark plugs or lower than normal compression due to apex seals locked into rotor groove from carbon accumulation.

NOTE:

- After repairs, provide customers with CUSTOMER INFORMATION (for customers to try after a "CRANKS, NO START" condition, before towing to dealership).

REPAIR PROCEDURE "A"

1. Verify concern by attempting to start engine.
 - If engine starts, return vehicle to customer.
 - If engine fails to start, go to STEP 2.

2. Disconnect the secondary air injection pump electrical connector (B1-04).

NOTE:

- This will protect the catalytic converter by preventing rapid light off due to unburned fuel purging from the engine in the following steps.

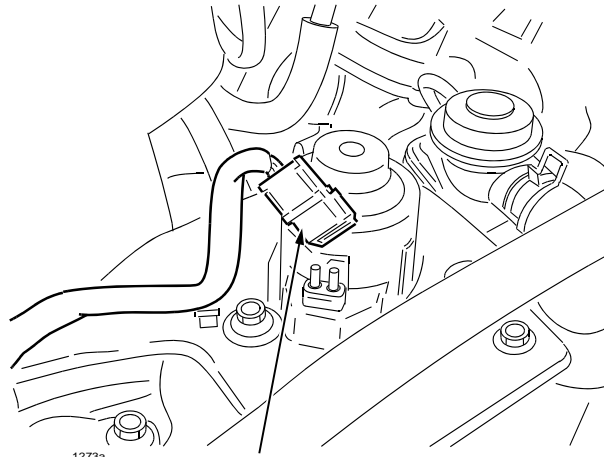

**SECONDARY
AIR INJECTION PUMP
CONNECTOR (B1-04)**

CAUTION:

- The following steps will force un-burnt fuel from the combustion chambers through the spark plug holes. Use caution not to create sparks or other sources of ignition during these steps. Perform this procedure in a well ventilated area.
3. Remove all 4 spark plugs from the engine. See workshop manual section 01-18 SPARK PLUG REMOVAL / INSTALLATION.
 4. Disconnect Eccentric Shaft Position Sensor (ESPS) B1-27 connector.

NOTE:

- This will cut fuel injection and spark while performing the procedure.

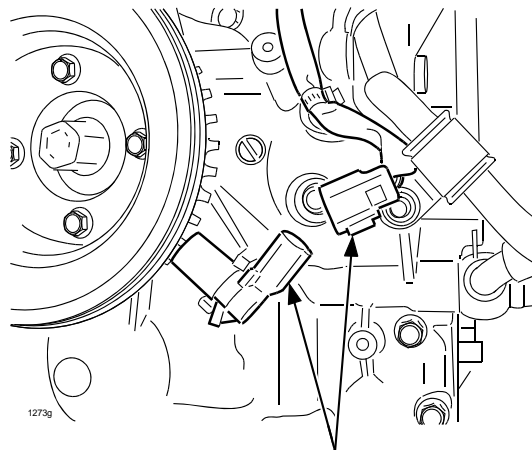

**DISCONNECT ECCENTRIC
SHAFT POSITION SENSOR**

5. Place cloth near spark plug holes to absorb fuel residue.
6. Crank the engine until all fuel is purged from spark plug holes. (Do not crank engine longer than 10 seconds. If more than 10 seconds is required, wait 5 seconds in between cranking.) Perform this procedure in a well ventilated area.
7. Connect ESPS connector B1-27.
8. Install new spark plugs.
9. Attempt to start engine without depressing accelerator pedal.
 - If the engine starts, go to STEP 10.
 - If engine fails to start, the engine compression may be lower than specification. Go to REPAIR PROCEDURE "B".
10. Keep engine running between 1500-2000 RPM until engine speed has stabilized. Maintain this engine speed until all smoke has dissipated and / or engine has come to full operating temperature.

NOTE:

- Do not race the engine, this may cause catalyst damage.

11. Shut engine off.
12. Connect the secondary air injection pump connector B1-04.
13. Erase all DTCs and confirm repairs.

REPAIR PROCEDURE "B"

1. Disconnect Eccentric Shaft Position Sensor (ESPS) B1-27 connector.

NOTE:

- This will cut fuel injection & spark while performing the procedure.

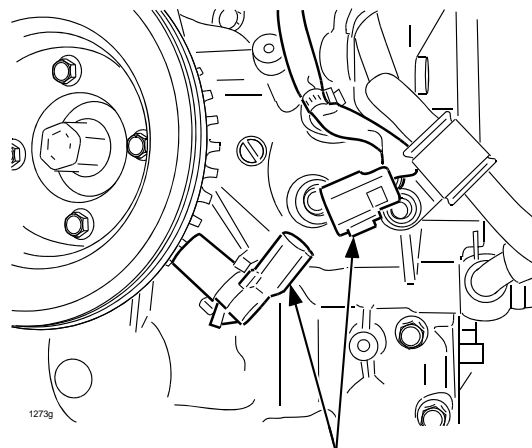

DISCONNECT ECCENTRIC
SHAFT POSITION SENSOR

2. Remove the front vacuum plug or PCV vacuum hose from the passenger side of the lower intake manifold.

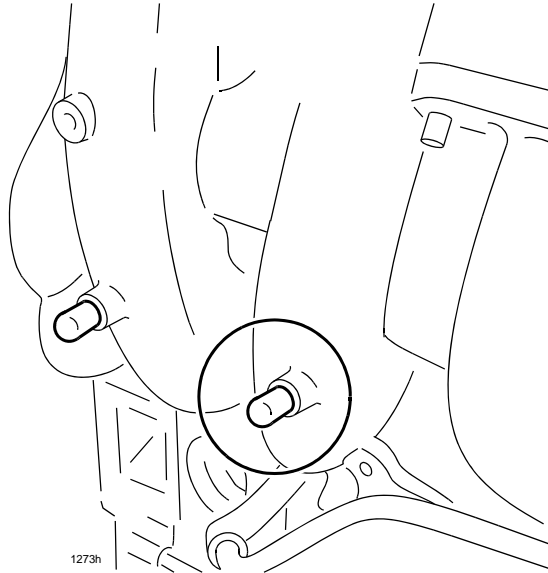

NOTE:

- There are PCV vacuum hoses attached to these ports for the PCV system. Disconnect these hoses from the lower intake manifold ports one at a time when performing this procedure. These hoses do not need to be plugged once disconnected.

3. Fabricate a vacuum line (About 2 feet in length) and attach to front vacuum port as shown in the illustration.

CAUTION:

- DO NOT attempt to service both vacuum ports at the same time. Perform procedure for front port, then perform procedure for rear port.

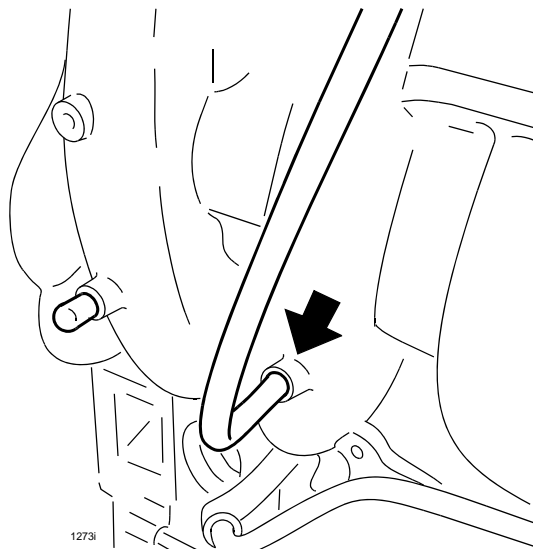

4. Add approximately 30cc's of 5W-20 **engine oil** to a small container.

5. Insert vacuum line into the bottom of the container.

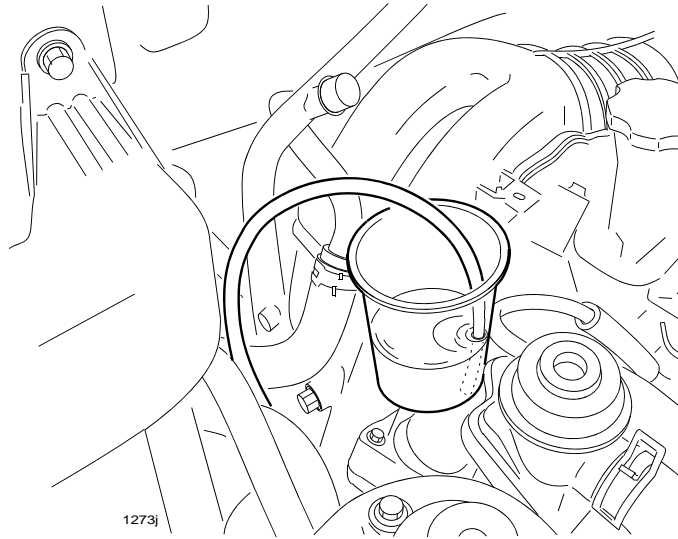

6. Crank over engine until all oil is drawn into the intake manifold. (Do not depress accelerator pedal during this step.)

NOTE:

- If oil cannot be drawn into engine due to low vacuum, add oil through leading spark plug holes, or use a syringe and inject through vacuum lines & into the intake manifold. Add approximately 30cc's of 5W-20 of **engine oil** to each rotor.

7. Reinstall leading spark plug if removed during STEP 6, then disconnect vacuum line from intake manifold and reinstall PCV vacuum line.
8. Repeat STEPS 2-7 for rear vacuum port.
9. Connect ESPS connector B1-27.

CAUTION:

- If the engine starts during next step, **DO NOT** race the engine, this may cause catalyst damage.

10. Attempt to start engine without depressing accelerator pedal.

- **If engine starts**, keep engine running between 1500-2000 RPM until engine speed has stabilized. Maintain this engine speed until all smoke has dissipated and / or engine has come to full operating temperature. Turn engine off and proceed to CARBON REMOVAL PROCEDURE.
- **If engine fails to start**, check engine compression. Refer to Workshop Manual section 01-10 COMPRESSION INSPECTION. Fill out the ENGINE COMPRESSION WORKSHEET and input vehicle information and your readings on the MXConnect website as instructed on the worksheet. If engine compression is OK, follow diagnosis according to workshop manual section 01-03 - NO.6 CRANKS NORMALLY BUT WILL NOT START.

NOTE:

- When engine compression readings and vehicle information are input to the form on the MXConnect website, the system will automatically determine if the engine requires or does not require replacement based on the compression.

IMPORTANT:

- If engine replacement is necessary, attach compression test results to the repair order in the form of:
 - Printed copy from print capable devices – Mazda Rotary Engine Compression Tester 49F0-18-9A0C, WDS compression test function or Mazda Rotary Engine Compression Tester 4908-20-280K.
 - Printed digital photo of compression tester screen - Mazda Rotary Engine Compression Tester 49H0-75-280, 49H0-75-280A, 49F0-18-9A0A, 49F0-18-9A0B.

ENGINE COMPRESSION WORKSHEET

Use this form to fill in information on MX Connect website to determine if it is necessary to replace an engine.
Complete form only as directed by the repair instructions.

VIN

MILEAGE

Engine Compression Test Results

- Record compression test results on this sheet.
- Enter results in MXCONNECT website. (See instructions below)
- Website will automatically determine if engine replacement is necessary.

1) Circle unit of measurement used for this compression test-

kPa

kgf/cm2

PSI

2) Enter compression test results in boxes below.

FRONT ROTOR

1

2

3

RPM

REAR ROTOR

1

2

3

RPM

Log on to MX Connect.

- Click on "Parts and Accessories" located on the top menu bar.
- Under "Support" on the right side of the screen click on "RX-8 Engine Replacement Authorization".
- Click on "Engine No Start Concern".
- Fill in the required data using the information from this form. You will automatically be directed to the next item as the data is entered.

CARBON REMOVAL PROCEDURE

WARNING:

- PLEASE USE CAUTION WHEN USING ENGINE CLEANER.
- WEAR EYE PROTECTION AND GLOVES WHEN HANDLING.
- ENGINE CLEANER IS FLAMMABLE.

NOTE:

- It **IS NECESSARY** to perform CARBON REMOVAL when REPAIR PROCEDURE “B” is performed. If vehicle started when performing REPAIR PROCEDURE “A”, it **IS NOT NECESSARY** to perform CARBON REMOVAL.
 - An assistant may be necessary while performing this procedure.
 - Approximately half a can of engine cleaner will be used per vehicle during this repair.
1. Cleaner kit comes with engine cleaner (A) and engine cleaner spray hose (B).

NOTE:

- Engine cleaner spray hose (B) is not used for this procedure and can be discarded.
- The can of engine cleaner (A) will have a red plastic spray tube attached to it. This red spray tube will be used for this procedure.

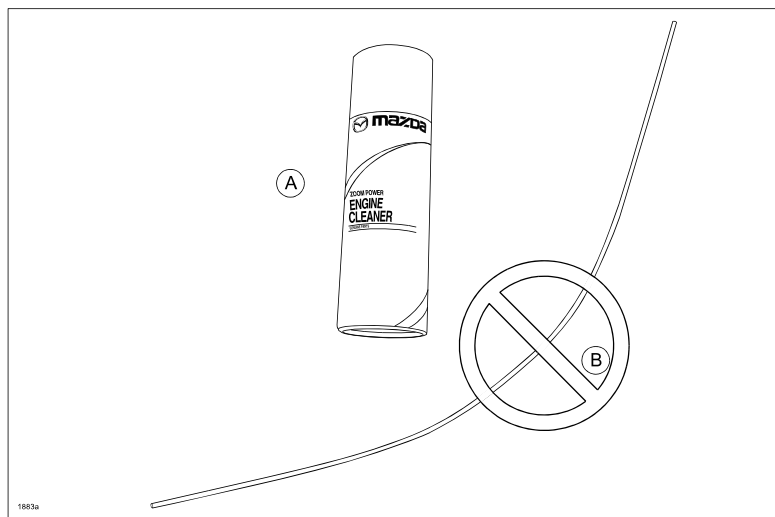

2. Cut a piece of electrical tape 2" (5cm) long and wrap around the end of the red spray tube.

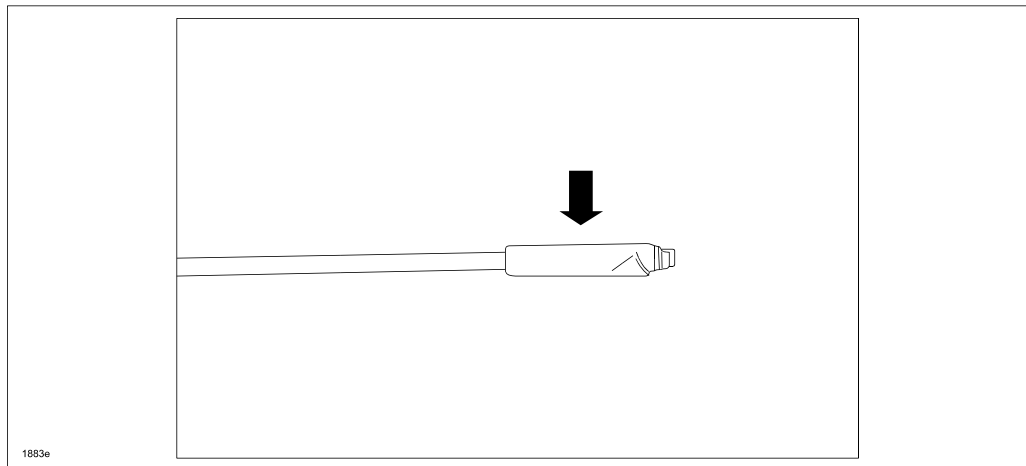

3. Cut a length of 1/8" inside diameter (ID) vacuum hose (obtained locally) to 27" (70cm). Insert tape wrapped end of red spray tube into vacuum hose and use a tie wrap to hold in place.

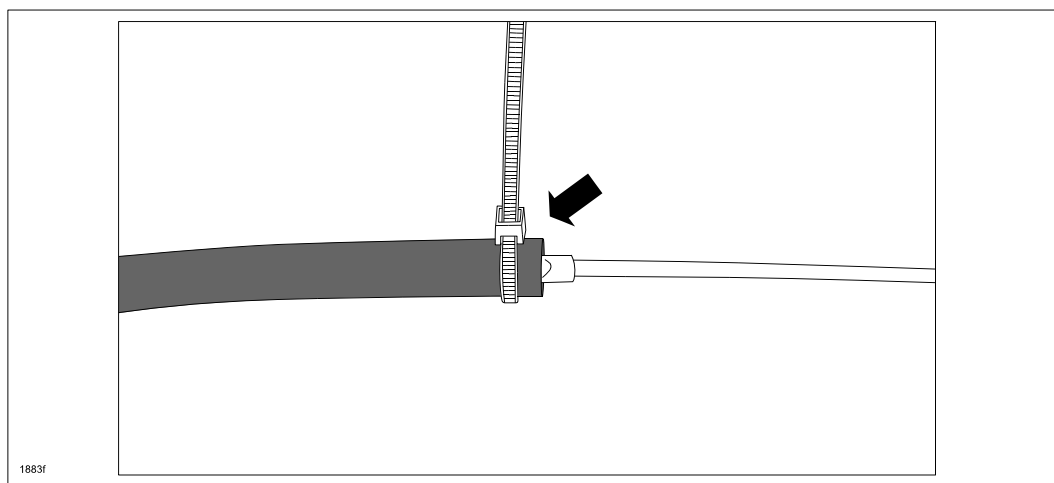

4. Disconnect Eccentric Shaft Position Sensor (ESPS) B1-27 connector.

NOTE:

- This will cut fuel injection and spark while performing the procedure.

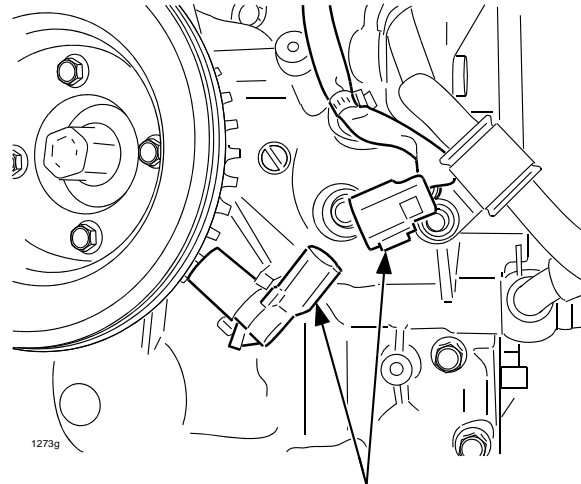

**DISCONNECT ECCENTRIC
SHAFT POSITION SENSOR**

5. Remove the front vacuum plug or PCV vacuum hose from the passenger side of the lower intake manifold.

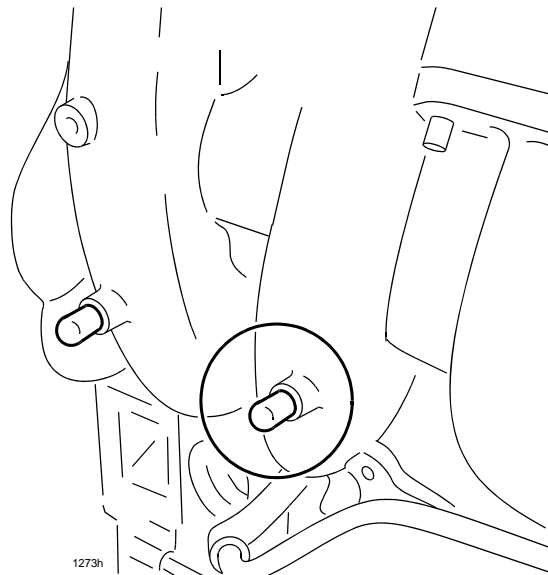

NOTE:

- There are PCV vacuum hoses attached to these ports for the PCV system. Disconnect these hoses from the lower intake manifold ports one at a time when performing this procedure. These hoses do not need to be plugged once disconnected.

CAUTION:

- DO NOT attempt to service both vacuum ports at the same time. Perform procedure for front port, then perform procedure for rear port.

6. Attach the vacuum hose end into front port nipple.

NOTE:

- Ensure the vacuum hose is securely connected to the nipples to prevent the hose from becoming detached while spraying engine cleaner.

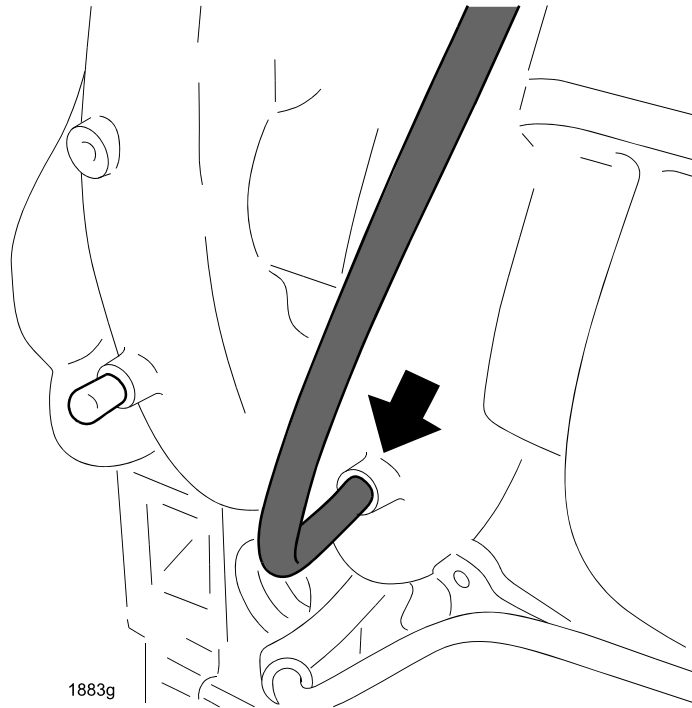

1883g

7. Attach the red spray hose end into the spray nozzle of the engine cleaner. Use care not to push down on the nozzle when inserting to prevent the can from spraying cleaner.

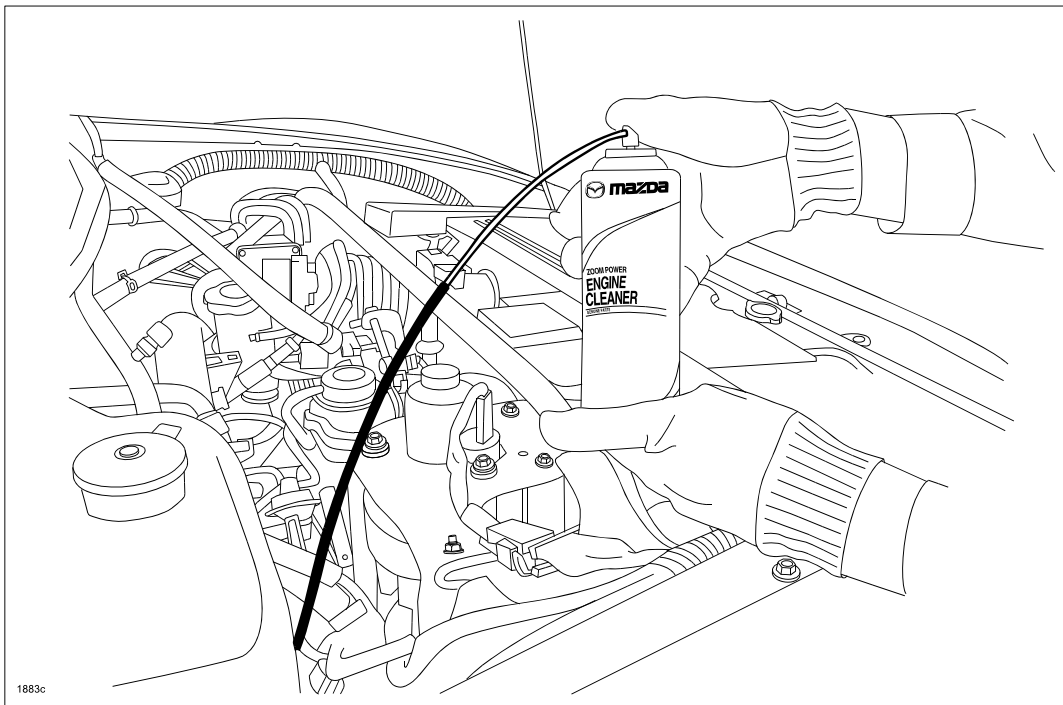

8. Have an assistant crank the engine. While cranking the engine, simultaneously depress the spray nozzle of the engine cleaner for a duration of 10 seconds. After 10 seconds, stop spraying and cranking at the same time. **DO NOT** depress accelerator pedal while cranking.
9. Wait a minimum of 30 seconds and repeat STEP 8 for the same port.
10. Remove the vacuum hose from the lower intake manifold nipple.
11. Reconnect PCV vacuum hose or install vacuum plug to front nipple.
12. Repeat STEPS 5-11 for rear nipple.
13. Allow the engine cleaner to soak for at least 1 hour before starting engine.
14. Connect ESPS connector B1-27.
15. Attempt to start engine without depressing accelerator pedal.
16. Keep engine running between 1500-2000 RPM until engine speed has stabilized. Maintain this engine speed until all smoke has dissipated and / or engine has come to full operating temperature.
CAUTION:
 - Do not race the engine during warm-up, this may cause catalyst damage.
17. Rev engine from idle speed up to 6,000 RPM, then release throttle immediately until RPM returns to idle speed.
18. Repeat 20 times with vehicle in Park (AT) or neutral (MT).
19. Connect M-MDS to vehicle and ID vehicle.
20. Using DATALOGGER, select MOP POS#
21. Perform METERING OIL PUMP (MOP) simulation test.

22. Using DATALOGGER, select MOP_FL_S# , RPM and ECT.

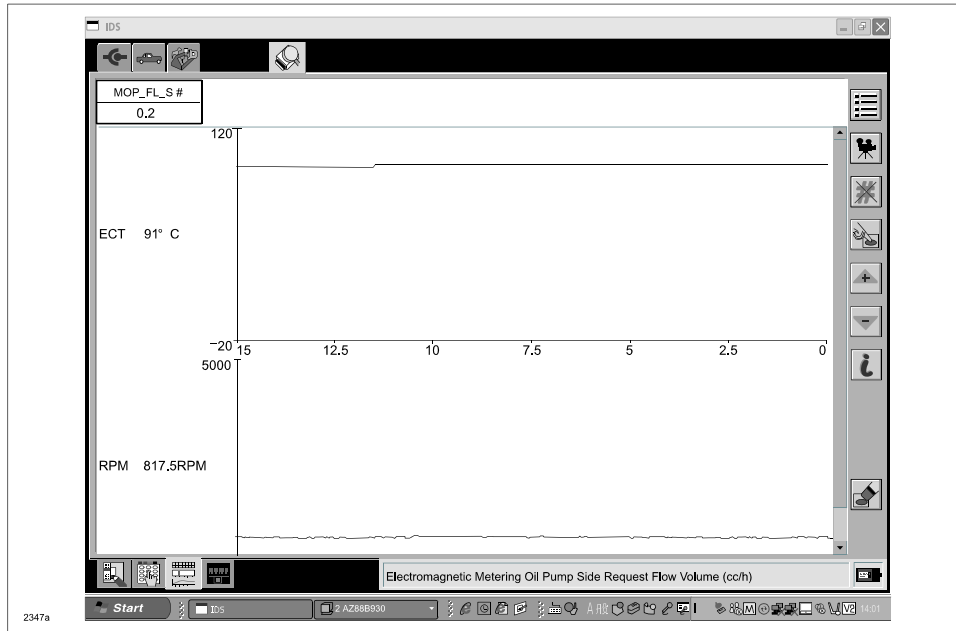

2347a

- A. Click on MOP_FL_S#.
- B. Click on “#” symbol.
- C. Click “finger” symbol.
- D. Click on “+ arrow up” symbol until MOP_FL_S# indicates “100”.

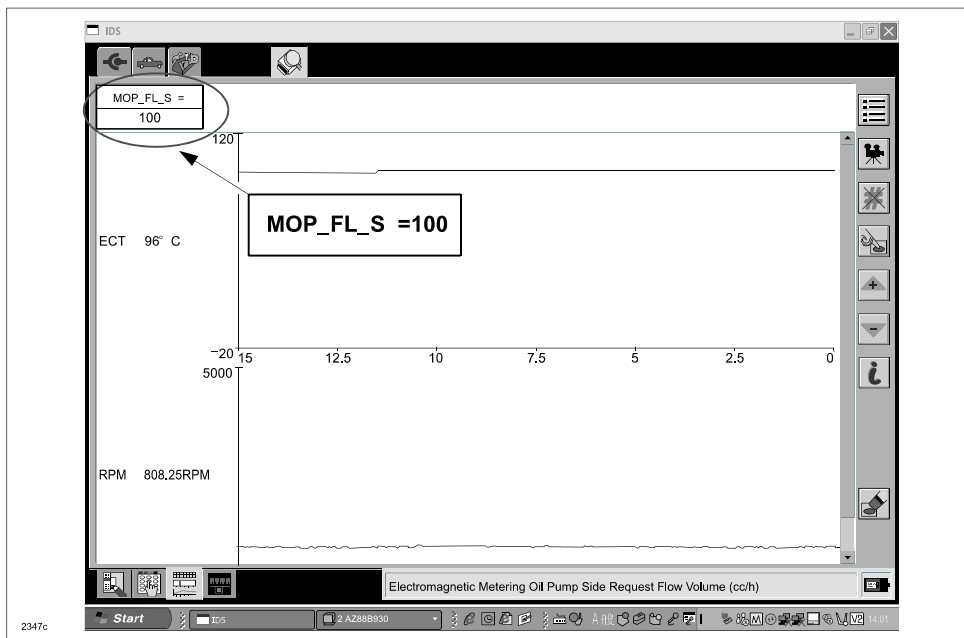
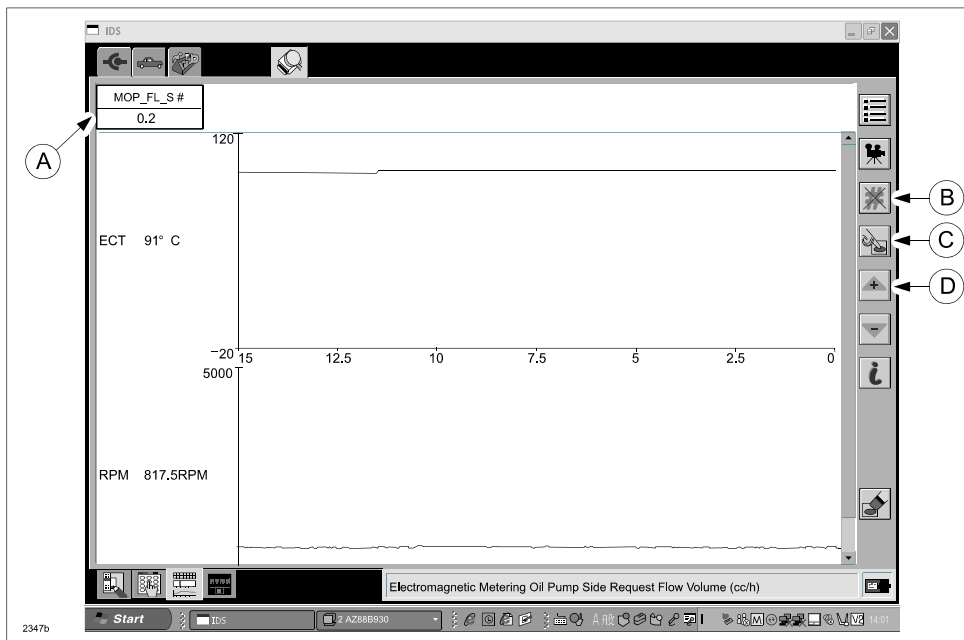

23. Allow engine to idle for 30 minutes with MOP_FL_S## at step 100.

NOTE:

- Make sure transmission is in NEUTRAL or PARK and all loads OFF (AC, blower etc.), do not touch accelerator pedal during this time or test will abort.

24. Tap accelerator pedal after the 30 minutes have elapsed to abort test. MOP_FL_S# will drop from step #100.

25. Turn engine off.

26. Connect the secondary air injection pump connector B1-04.

27. Check engine compression. Refer to Workshop Manual section 01-10 COMPRESSION INSPECTION. Fill out the ENGINE COMPRESSION WORKSHEET and input vehicle information and your readings on the MXConnect website as instructed on the worksheet. If engine compression is OK, go to STEP 28.

NOTE:

- When engine compression readings and vehicle information are input to the form on the MXConnect website, the system will automatically determine if the engine requires or does not require replacement based on the compression.

IMPORTANT:

- If engine replacement is necessary, attach compression test results to the repair order in the form of:
 - Printed copy from print capable devices – Mazda Rotary Engine Compression Tester 49F0-18-9A0C, WDS compression test function or Mazda Rotary Engine Compression Tester 4908-20-280K.
 - Printed digital photo of compression tester screen - Mazda Rotary Engine Compression Tester 49H0-75-280, 49H0-75-280A, 49F0-18-9A0A, 49F0-18-9A0B.

28. Erase all DTCs and confirm repairs.

PART(S) INFORMATION

NOTE:

- When vehicles experience a engine cranks but does not start concern due to fuel flooding, Mazda recommends the use of the standard spark plug set (**N3Y3-18-S30A-9U**).
- Standard spark plugs may be ordered as a set, or individually.

| Part Number | Description | Qty | Notes |
|------------------------|---------------------|-----|---|
| 0000-77-A86 | Engine Cleaner | 1 | Quantity 1 = 1 can of engine cleaner when ordered through eMDCS. 1 can of engine cleaner is sufficient for 2 engine cleanings. |
| N3Y3-18-S30A-9U | Spark Plug Set | 1 | Set contains N3Y1-18-110A-9U (QTY. 2), and N3Y8-18-110A-9U (QTY. 2) spark plugs |
| N3Y1-18-110A-9U | Leading Spark Plug | 2 | Leading spark plug, heat range 7 - NGK RE7C-L |
| N3Y8-18-110A-9U | Trailing Spark Plug | 2 | Standard trailing spark plug, heat range 9 - NGK RE9B-T |

WARRANTY INFORMATION

NOTE:

- This warranty information applies only to verified customer complaints on vehicles eligible for warranty repair.
- Warranty term coverage is 8 years (96 months) from the original warranty start date, with a 100,000 mile mileage limitation.
- Additional diagnostic time cannot be claimed for this repair.
- Complete Required Repairs must be entered on a Single Warranty Claim.

| | Repair Procedure "A" | Repair Procedures "A" + "B" |
|---|--|---|
| Warranty Type | A | A |
| Symptom Code | 02 | 02 |
| Damage Code | 93 | 93 |
| Part Number Main Cause | N3Y3-02-200A (Short Engine AT) N3Y4-02-200A (Short Engine MT) | N3Y3-02-200A (Short Engine AT) N3Y4-02-200A (Short Engine MT) |
| Part Quantity | 0 | 0 |
| Related Part Number - Spark Plugs - Reimbursement Engine Cleaner | Spark plugs ONLY See PART(S) INFORMATION | Spark plugs - See PART(S) INFORMATION Engine cleaner 5555-08-008A/Qty 1 Allowance applies to 1/2 can of engine cleaner per repair |
| Operation Number | XXB479R1 | XXB479R2 |
| Labor Hours | 0.5 Hrs. (Max. actual time) | 1.6 Hrs. (Max. actual time) |