

mazda COMPRESSION TESTER

49 H075 280

INSTRUCTION MANUAL

mazda

Foreword

This tester measures the maximum compression in each of the three combustion chambers formed by the rotor and the rotor housing in rotary engines and simultaneously measures the maximum value of the cranking revolution and that time and displays it on a digital indicator.

In addition, the compression of reciprocating engines can also be measured with the optical adaptor.

Name & Function of Parts

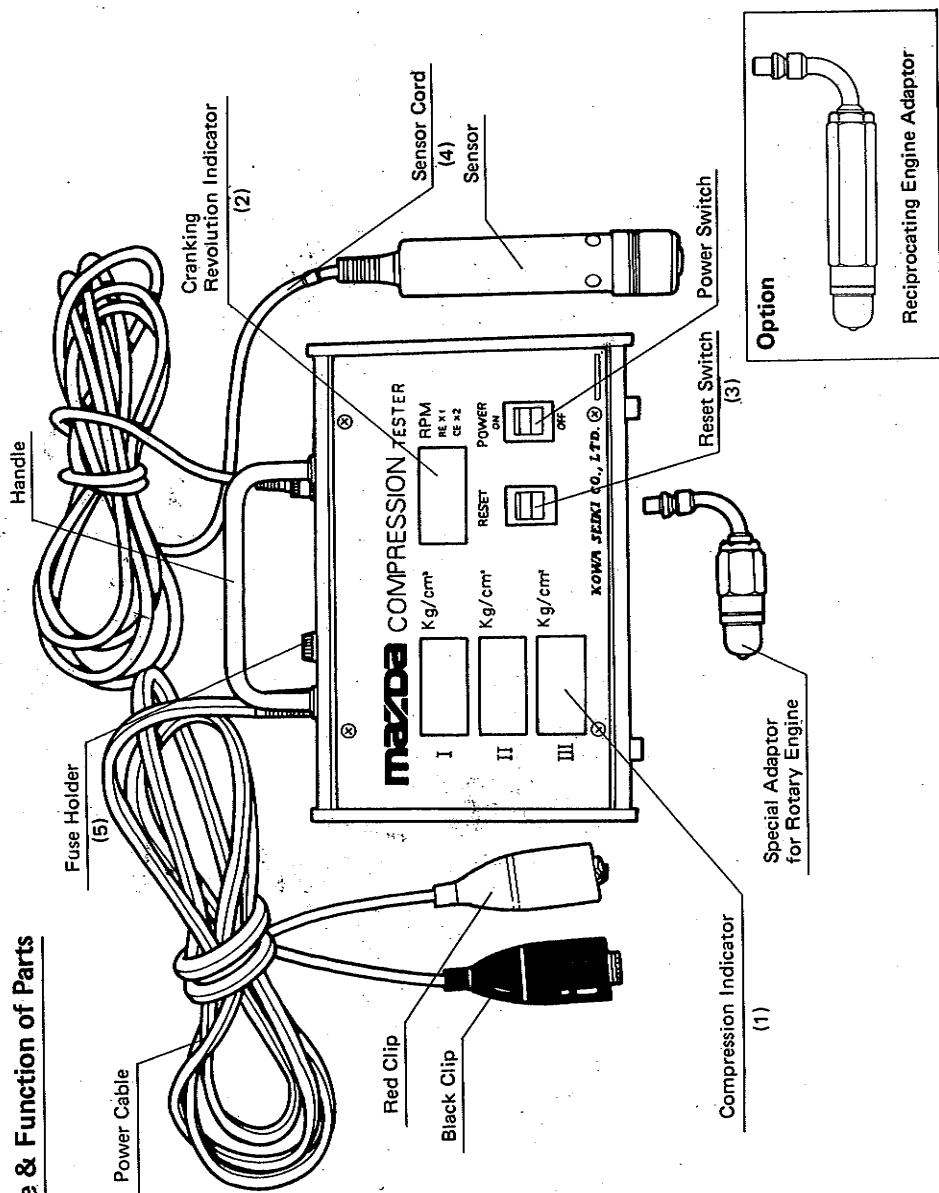

Handle

Fuse Holder (5)

Power Cable

Cranking Revolution Indicator (2)

Red Clip

Black Clip

Sensor Card (4)

Sensor

Compression Indicator (1)

Reset Switch (3)

Power Switch

Special Adaptor for Rotary Engine

Option

Reciprocating Engine Adaptor

- (1) **Compression Indicator**
This shows the maximum value of the compression accompanying the cranking revolutions as a digital indication.
- (2) **Cranking Revolution Indicator**
The maximum value of the cranking revolutions is shown as a digital indication.
- (3) **Reset Switch**
The values shown on the digital indicators revert to zero when this switch is pressed.
- (4) **Sensor and Sensor Cord**
These convert the compression into electrical signals and send them to the body of the meter.
- (5) **Fuse Holder**
The 1A fuse prevents miswiring and overloading from causing damage to the meter.

Method of Use

- (1) Check the state of charge of the battery. (A completely charged battery is desirable.)
- (2) Start the engine and allow it to warm up.
- (3) Stop the engine and leave vehicles equipped to the catalytic conveyor alone for about ten minutes.
- (4) Remove the positive couplers from the ignition coil and both the trailing and the leading side.
NB: Do this to prevent igniting any compound gas.
- (5) Remove the spark plug
Rotary Engine: Front & rear trailing plugs only
Reciprocating engine: All spark plugs
- (6) Attach the special adaptor to the spark plug hole of the cylinder when the compression is to be measured.
NB: Be sure to use the attached special adaptor.
- (7) Connect the power cable to the battery (DC 12V).
NB: Red clip Connect to the positive terminal of the battery.
 Black clip Connect to the negative terminal of the battery.
- (8) Switch on the power to the tester.
- (9) Switch the reset switch of the tester to ON. (All of the indications should revert to zero.)
NB: Turn the reset switch ON when the sensors are still unconnected.
- (10) Correctly set the adaptor attached to the engine.

Rotary Engine

- (11) Fully open the throttle and crank for over 5 seconds.

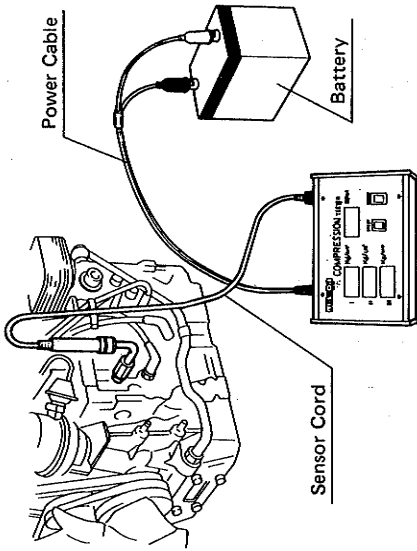

- (12) Stop cranking and read the compression and the revolution values. Record them.
- (13) Be sure to remove the sensors from the special adaptor before repeating measurements.
- (14) Find the correct compression from the data on the rear of the meter.
- NB:a) Refer to the service manual for the interpretation of the compression reading.
- NB:b) The I, II, III indicators may not give the same indication for repeated measurements of the same cylinder.

Reciprocating Engine

- (11) Fully open the throttle and crank for over 5 seconds.

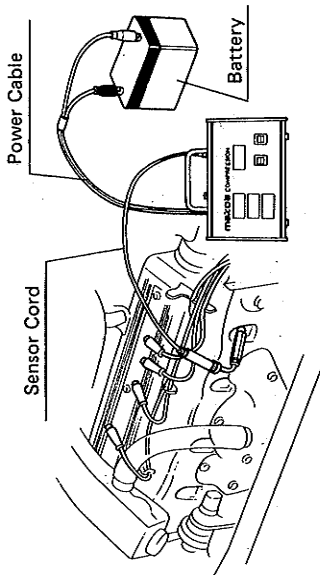

- (12) Stop cranking and read the compression and the revolution values. Record them.
- (13) Be sure to remove the sensors from the special adaptor before repeating measurements.
- (14) The compression in the value indicated on the meter. The cranking revolutions are twice this value.
- NB:a) Refer to the service manual for the interpretation of the compression reading.
- NB:b) The peak compressions for every three cycles of the cylinder being measured are indicated on the I, II, III indicators.

Handling Cautions

- (1) Do not use any battery other than a DC 12V battery.
- (2) Do not mistake the polarity of the power cable connections.
Red clip connect to the positive terminal of the battery
Black clip connect to the negative terminal of the battery
- (3) Do not jolt the equipment during testing.
- (4) Wipe off oil, dust and the like from the panel surface using a dry cloth. Do not store in hot or moist places.

Accuracy Check Method

1. Use the following process to check the accuracy during operation.
 - 1.1 Connect the power.
 - 1.2 Switch on the power. Switch the reset switch of the tester to ON. (All of the indications should revert to zero.) At this stage, reset so that there is no pressure in the sensor. There is an open air condition inside the sensor when the attachments are not connected to the sensor.
 - 1.3 Apply 5kg/cm² static pressure to the sensor. The circuit is as follows due to the stability of the measurement values.

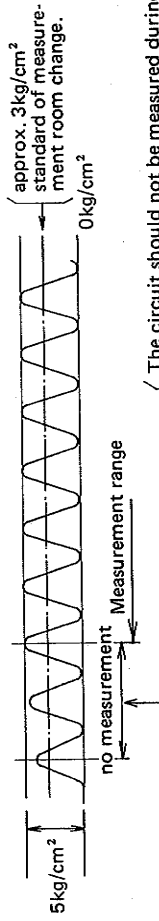

NB: When the pressure in the sensor is to be 0kg/cm², the sensor part must be removed from the attachment and performed in an open air condition.

The circuit should not be measured during this time (three parabolas). Therefore, the static pressure should be applied as the above curve and then the following adjustment should be performed after the pressure for the third parabola is shown.

1.4 For $5\text{kg}/\text{cm}^2$ static pressure (after the three parabolas), an adjustment must be made by VR2 to indicate $5.6\text{kg}/\text{cm}^2$. (In the case of 12.5% up compensation.)

Example A: Rotate VR2 clockwise for when the display shows less than $5.6\text{kg}/\text{cm}^2$ for $5\text{kg}/\text{cm}^2$. (Use the method shown in Example B when it exceeds $5.6\text{kg}/\text{cm}^2$.)

Example B: When the display shows over $5.6\text{kg}/\text{cm}^2$, the value on the display does not decrease with clockwise rotation of VR2 (due to the peak hold form).

Therefore an adjustment must be made by the following process. Switch off the power source → bring the pressure in the sensor down to $0\text{kg}/\text{cm}^2$ → rotate VR2 clockwise (about 3 times) → make an adjustment by processes 1.1–1.4.

2. Accuracy Check Method when the sensor part is changed.

2.1 Connect power source.

2.2 Connect the sensor part to the main body using a connector.

2.3 Power source must be ON—OFF—ON.

Pressure in the sensor part must be $0\text{kg}/\text{cm}^2$ (in open air).

2.4 Apply $5\text{kg}/\text{cm}^2$ static pressure to the sensor part. Apply 1.3 correspondingly for the way to apply static pressure.

Example A: For $5\text{kg}/\text{cm}^2$ static pressure, if the value on the display is under $7.1\text{kg}/\text{cm}^2$, an adjustment should be made by slowly rotating VR1 anti-clockwise in order to bring this value to $7.1\text{--}7.2\text{kg}/\text{cm}^2$.

Example B: For $5\text{kg}/\text{cm}^2$ static pressure, if the value on the display is over $7.1\text{kg}/\text{cm}^2$, switch off the power source → pressure in the sensor must be $0\text{kg}/\text{cm}^2$, → rate VR1 anti-clockwise (about 1 rotation). → make an adjustment by processes 2.3–2.4.

NB: Do not reset for this.

3. Accuracy Check Cautions

This tester is designed to have an accuracy within 2%.
It is recommended that a highly accurate gauge be used for the accuracy check.

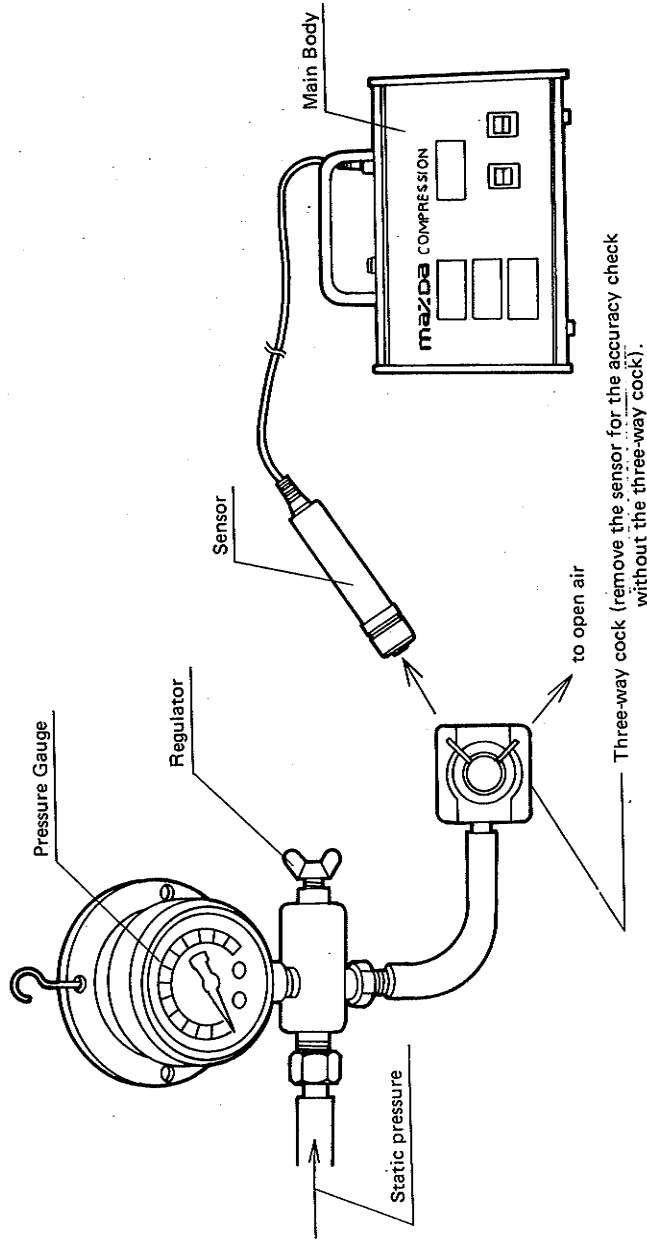

Three-way cock (remove the sensor for the accuracy check without the three-way cock).

Major Specifications

Indication Method	LED (8 segment), 3 columns
Maximum reading	Compression 19.9kg/cm ²
	Cranking revs. 500rpm
Minimum reading	Compression 0.1kg/cm ²
	Cranking revs. 1rpm
Measurement Precision	Compression $\pm 2\%$ FS ± 1 dgt
	Cranking revs. $\pm 2.5\%$ FS ± 1 dgt
Usable temperature range	0°C – 40°C
Power source	DC 12V (Measurement possible from DC8V – 15V)
Measurement time	0.5 msec
Dimensions of main body	200 (w) X 135 (d) X 65 (h) mm
Weight	1.5kg

Malfunction Diagnosis and Treatment

Malfunction	Cause	Treatment
Values are not indicated when the power is switched ON.	<ol style="list-style-type: none"> (1) Power cord is in-² correctly connected. (2) Blown fuse. (3) Flat battery. (4) Severed power cable. 	<ol style="list-style-type: none"> (1) Correctly connect. (2) Replace the fuse. (3) Recharge battery. (4) Replace the power cable.
Scattered measurement values.	<ol style="list-style-type: none"> (1) Improper connection of sensor/adaptor. (2) Severed wire or damage inside sensor. (3) Severed sensor cord. (4) Reset switch was not pressed. 	<ol style="list-style-type: none"> (1) Correctly attach the sensor. (2) (3) Replace the sensor and the sensor cord. (4) Press the reset switch. (Refer to 2. (9).)

If the malfunction persists after the above treatment has been conducted then it is likely that there is internal (printed circuit, etc) damage and so the tester should be repaired by KOWA SEIKI LOS ANGELES Branch.

Guarantee

This company will accept responsibility for any fault or damage to this meter or its construction and both repair labor and parts will be provided free of charge.

The period of guarantee is reckoned one year from the date of delivery.

However, the guarantee does not apply to the repair of damages resulting from the following:

- a) Deterioration of parts with time.
- b) Damage caused by natural disasters such as earthquakes, typhoons, floods, etc.
- c) Usage that exceeds the meter's specified capabilities.
- d) Cases of wilful and unreasonable handling.



KOWA SEIKI CO., LTD.

No. 13-17-1 chome, Shiba, Minato-ku, Tokyo, Japan. Zip Code 105
Tel. 03 (453) 6011
FAX: GIII 03 (453) 6010

Branch: LOS ANGELES 137E
SAVORONA WAY,
CARSON CA., 90746
Tel. 213 (327) 1714
FAX. 213 (515) 1246

(PRINTED IN JAPAN)
© TOYO KOGYO CO., LTD.