

Subject: DASH CENTER PANEL (AUDIO, RADIO, CLIMATE CONTROL) REMOVAL - SERVICE TIP	Bulletin No: 09-013/03
	Last Issued: 9/5/2003

APPLICABLE MODEL(S)/VINS

RX-8

DESCRIPTION

There is a hidden bolt {behind driver lower panel (kick panel)} that must be removed in order to pull out the audio system, HVAC controls and center panel. See instructions below.

REPAIR PROCEDURE

1. Record customer radio station presets, then disconnect the negative battery cable.
2. Remove the shift knob (unscrew counterclockwise).
3. Remove the upper panel by pulling to release clips marked "A"

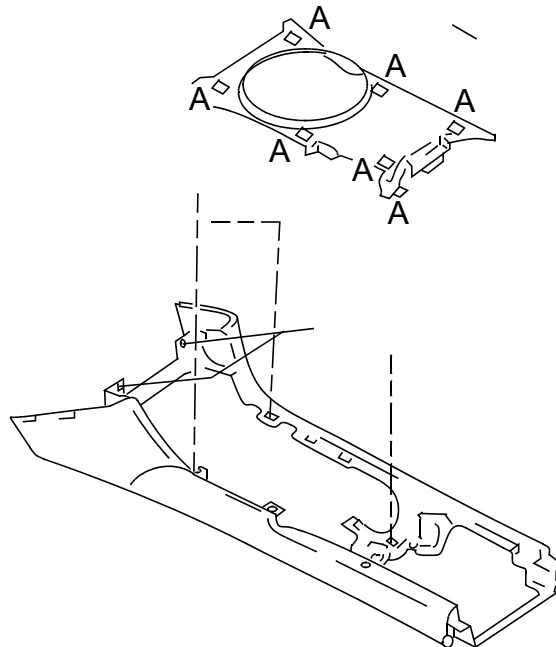

1230a

CONSUMER NOTICE: The information and instructions in this bulletin are intended for use by skilled technicians. Mazda technicians utilize the proper tools/equipment and take training to correctly and safely maintain Mazda vehicles. These instructions should not be performed by "do-it-yourselfers." Customers should not assume this bulletin applies to their vehicle or that their vehicle will develop the described concern. To determine if the information applies, customers should contact their nearest authorized Mazda dealership. Mazda North American Operations reserves the right to alter the specifications and contents of this bulletin without obligation or advance notice. All rights reserved. No part of this bulletin may be reproduced in any form or by any means, electronic or mechanical--including photocopying and recording and the use of any kind of information storage and retrieval system ---without permission in writing.

4. Remove 2-screws securing the ashtray marked "1".

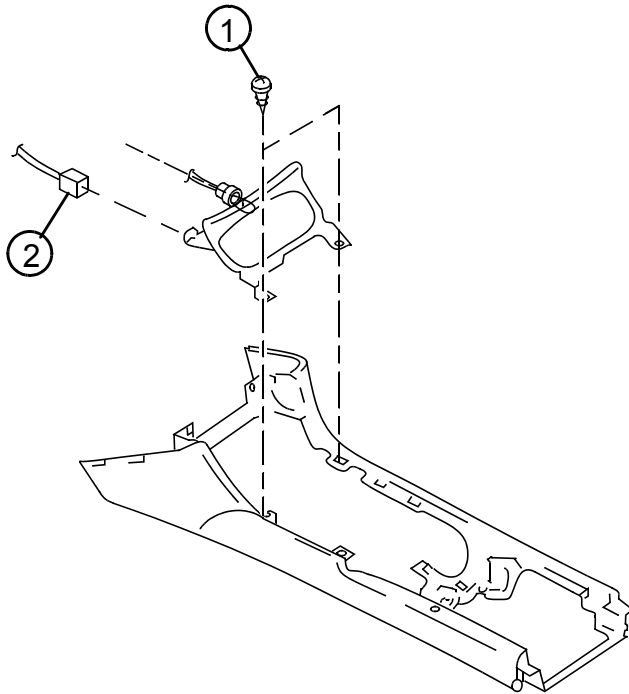

1230b

5. Disconnect the cigarette lighter electrical connector (2) (leave the ashtray illumination bulb connected) and allow the ashtray to hang out of the way.
6. Remove the lower panel (driver's kick panel):
 - a. Pull the top of the panel towards you to release the clips "A"
 - b. Unhook the lower edge of the panel "B"

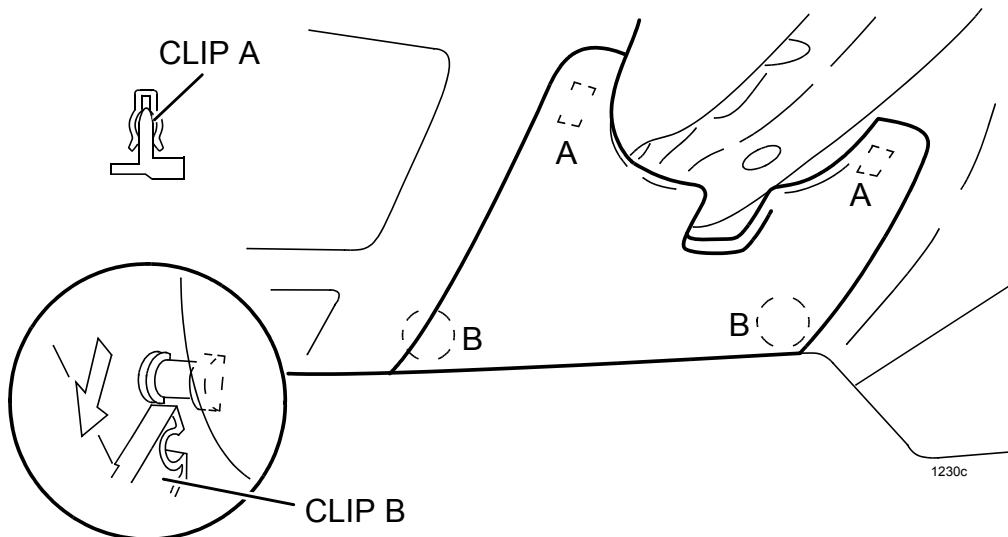

1230c

7. Remove the **hidden 10mm bolt** securing the radio to the plastic panel (behind the driver side of the dash).

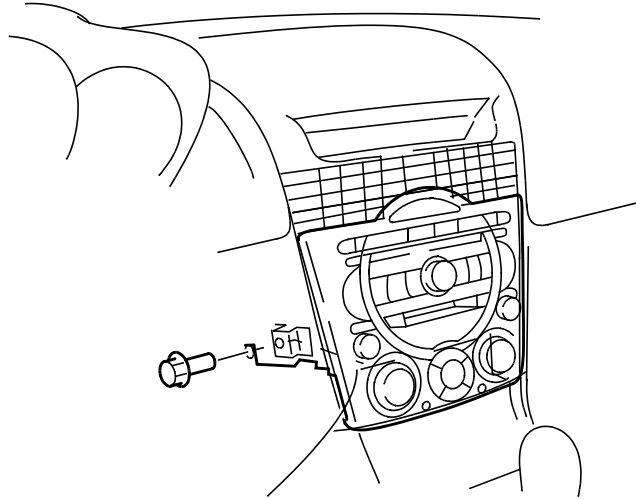

1230e

8. Remove bottom 2-screws from the center panel.

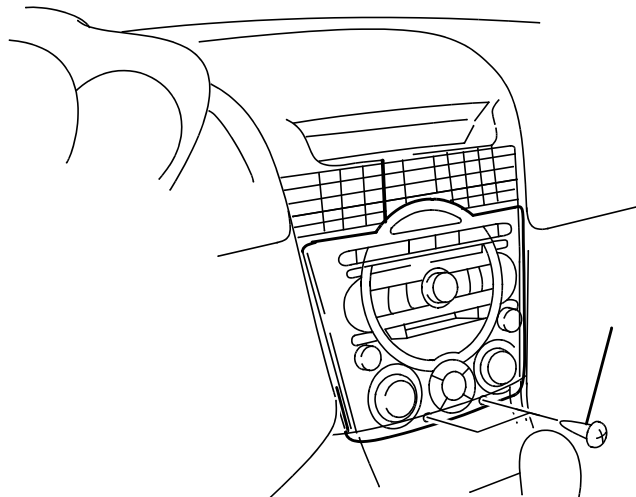

1230c

9. Use fiber boards or a small screwdriver wrapped with electrical tape to protect the dash and pry the radio to release the clips marked "A".

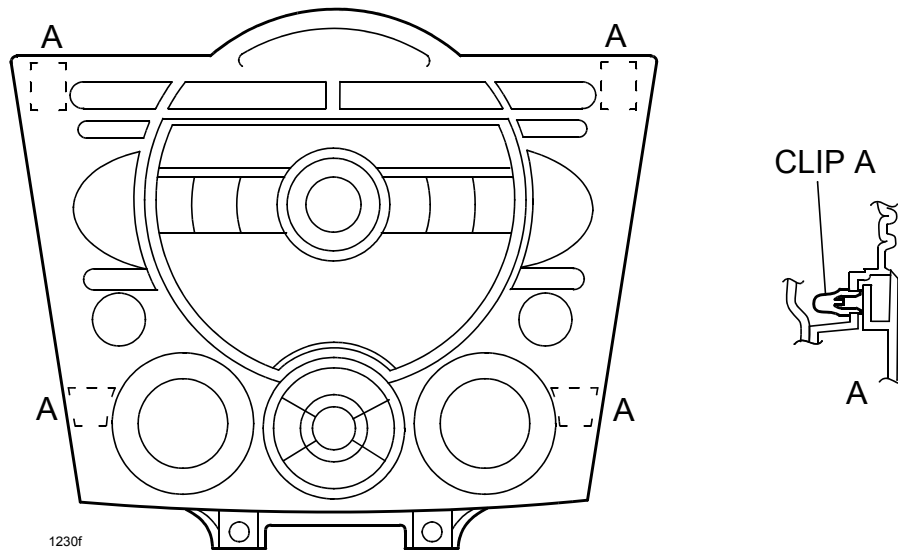

10. Disconnect the electrical connectors and antenna cable from the back of the center panel.

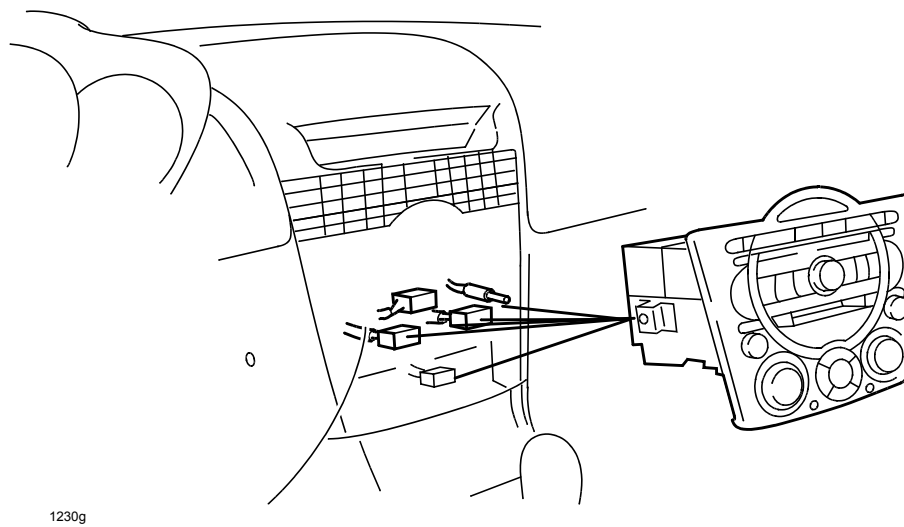

11. Installation is the reverse of removal.