

# ELECTRIC POWER STEERING

## STEERING

(w)

### STEERING LOCATION INDEX

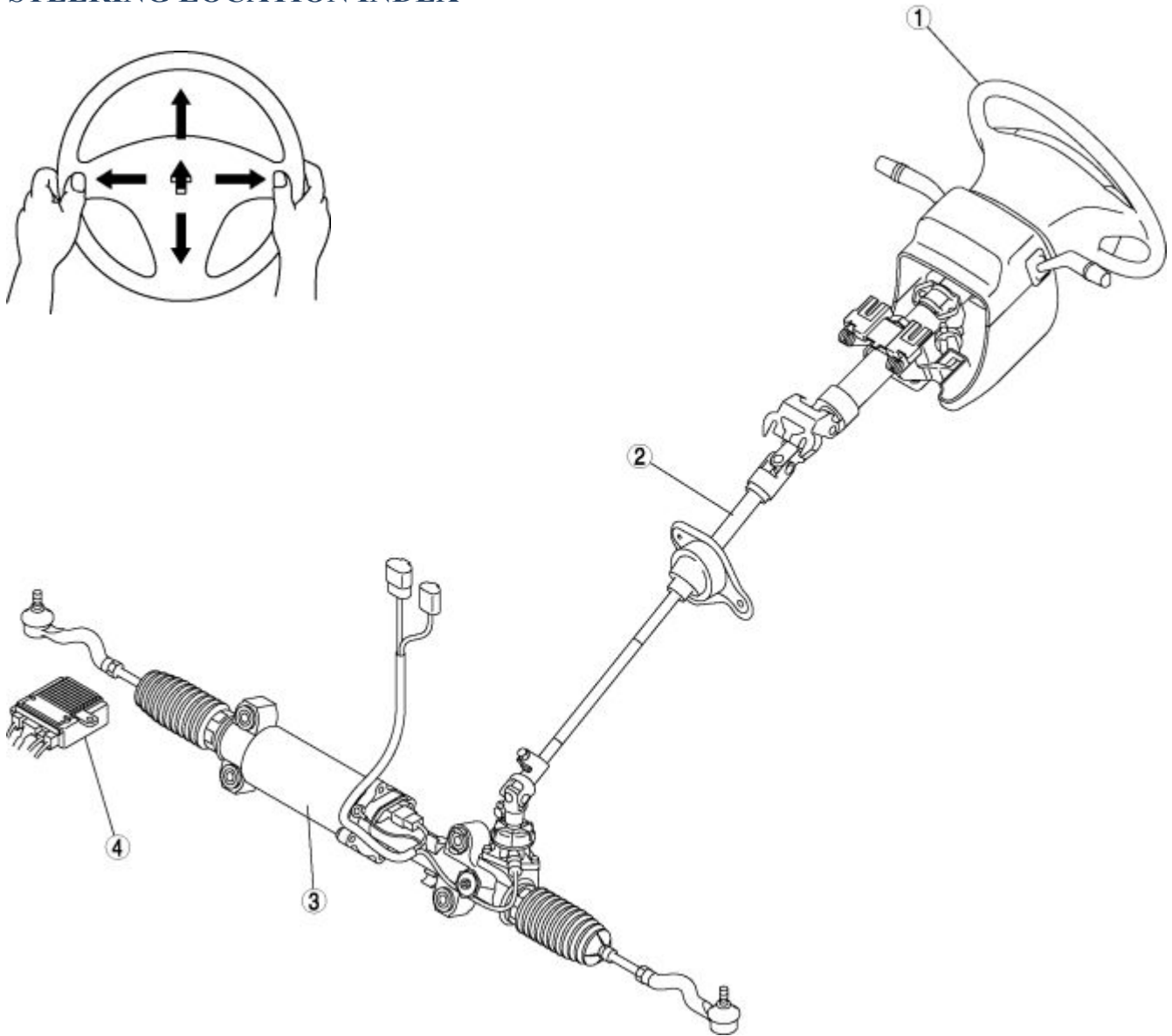

	Steering wheel and column
1	(See STEERING WHEEL AND COLUMN INSPECTION .) (See STEERING WHEEL AND COLUMN REMOVAL/INSTALLATION .)
2	Steering shaft (See STEERING SHAFT INSPECTION .)
3	Steering gear and linkage

(See STEERING GEAR AND LINKAGE REMOVAL/INSTALLATION .)

(See STEERING GEAR AND LINKAGE INSPECTION .)

(See STEERING GEAR AND LINKAGE DISASSEMBLY/ASSEMBLY .)

(See STEERING GEAR AND LINKAGE ADJUSTMENT .)

EPS control module

(See EPS CONTROL MODULE REMOVAL/INSTALLATION .)

(See EPS CONTROL MODULE INSPECTION .)

(See EPS SYSTEM NEUTRAL POSITION SETTING .)

## STEERING WHEEL AND COLUMN

### STEERING WHEEL AND COLUMN INSPECTION

#### Play Inspection

1. With the wheels in the straight-ahead position, start the engine.
2. Turn the steering wheel to the left and right gently, and verify that the steering wheel play is within the specification.

#### Play

- 0—30 mm {0—1.2 in}

#### Looseness, Play Inspection

1. Move the steering wheel toward the shaft and in four right angle directions to inspect for looseness and play.

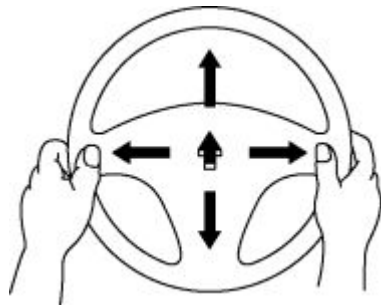

If there is any malfunction, inspect the following, and repair or replace the applicable part.

- Column bearing wear
- Looseness of the steering wheel installation part
- Looseness of the column installed part
- Excessive play of the steering shaft joint
- Excessive play of the steering gear

## Steering Wheel Effort Inspection

1. Verify that the equipped tire size and tire air pressure is as specified.
2. With the vehicle on a hard, level surface, put the wheels in the straight-ahead position.

### WARNING:

Handling the air bag module improperly can accidentally deploy the air bag module, which may seriously injure you. Read the service warnings before handling the air bag module. (See SERVICE WARNINGS .)

3. Remove the air bag module.
4. Start the engine and idle it.
5. Verify that the EPS warning light does not illuminate.
6. Inspect the steering wheel effort using a torque wrench.

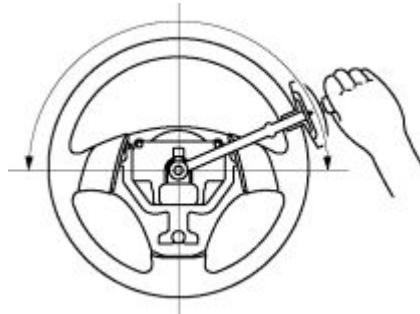

If it exceeds the reference value, adjust the steering gear and linkage. (See STEERING GEAR AND LINKAGE ADJUSTMENT .)

### Reference value

- 5.0 N·m {50 kgf·cm, 44 in·lbf} or less

### NOTE:

To determine whether the steering effort is satisfactory or not, perform the inspection on another vehicle of the same model and under the same conditions, and compare the results.

The steering wheel effort varies with conditions indicated below.

- Road conditions: such as dry or wet, asphalt or concrete
- Tire conditions: such as brand, wear, and tire air pressure

## STEERING WHEEL AND COLUMN REMOVAL/INSTALLATION

### WARNING:

Handling the air bag module improperly can accidentally deploy the air bag module, which may seriously injure you. Read the service warnings before handling the air bag module. (See SERVICE WARNINGS .)

After replacing the steering shaft, always set the EPS system to the neutral position to prevent system malfunction. (See EPS SYSTEM NEUTRAL POSITION SETTING .)

### NOTE:

When replacing the steering lock of vehicles with the immobilizer system, perform the following procedure:

(See IMMOBILIZER SYSTEM COMPONENT REPLACEMENT/KEY ADDITION AND CLEARING .)

1. Remove the air cleaner and air cleaner insulator. (See INTAKE-AIR SYSTEM REMOVAL/INSTALLATION .)
2. Remove in the order indicated in the table.
3. Install in the reverse order of removal.
4. After installation, set the EPS system to the neutral position. (See EPS SYSTEM NEUTRAL POSITION SETTING .)

Notes:

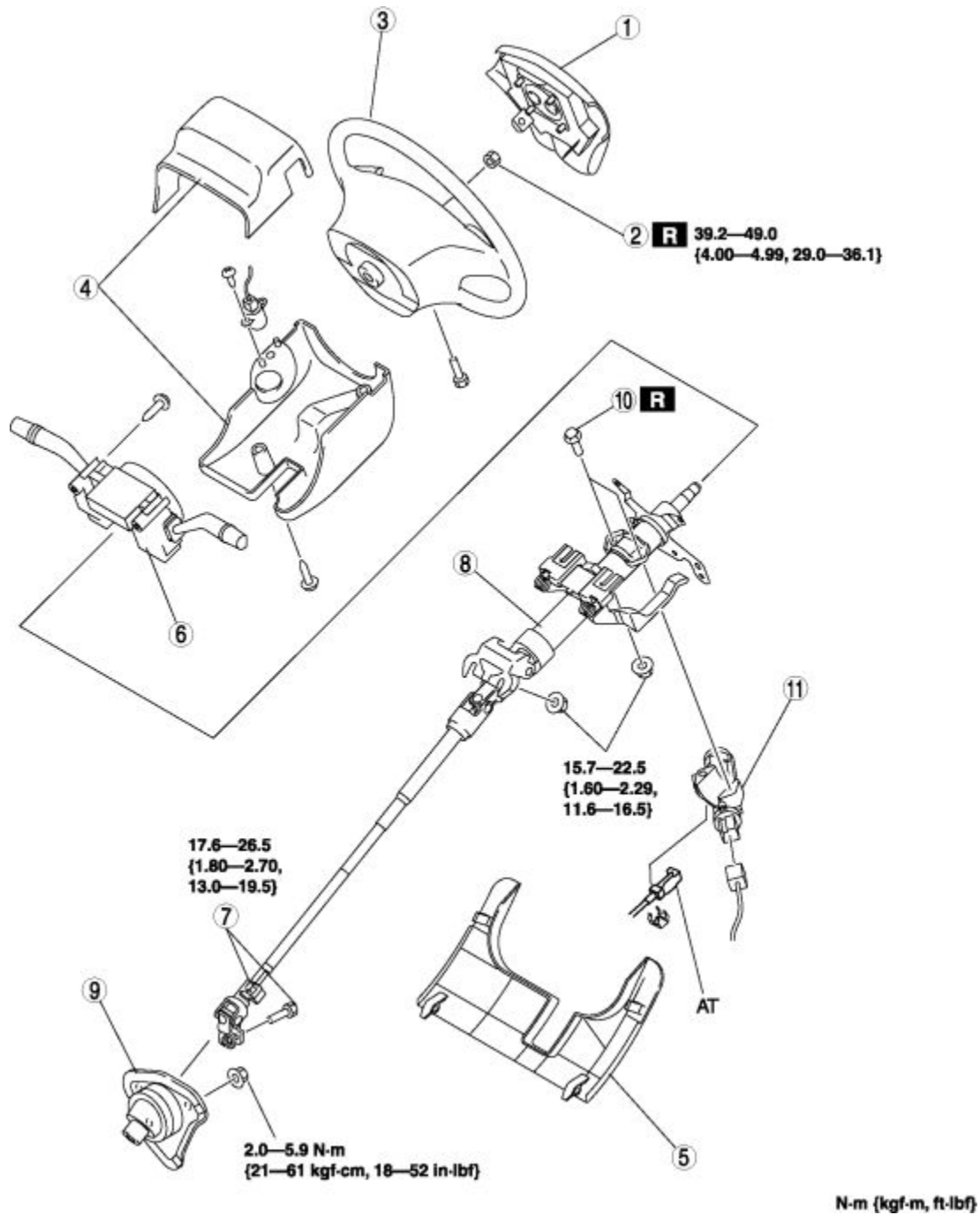

1	Air bag module (See DRIVER-SIDE AIR BAG MODULE REMOVAL/INSTALLATION .)
2	Locknut
3	Steering wheel (See Steering Wheel Removal Note .) (See Steering Wheel Installation Note .)
4	Column cover
5	Under cover

6	Clock spring, combination switch (See COMBINATION SWITCH REMOVAL/INSTALLATION .)
7	Bolt (intermediate shaft) (See Bolt (Intermediate Shaft) Removal Note .) (See Bolt (Intermediate Shaft) Installation Note .)
8	Steering shaft (See Steering Shaft Installation Note .)
9	Dust cover
10	Steering lock mounting bolt (See Steering Lock Mounting Bolt Removal Note .) (See Steering Lock Mounting Bolt Installation Note .)
11	Steering lock

### Steering Wheel Removal Note

#### CAUTION:

Do not try to remove the steering wheel by hitting the shaft with a hammer. The column will be damaged.

1. Set the wheels in the straight-ahead position.
2. Remove the steering wheel using any commercially available puller.

### Bolt (Intermediate Shaft) Removal Note

1. Place alignment marks on the intermediate shaft joint, and the steering gear and linkage for proper installation.

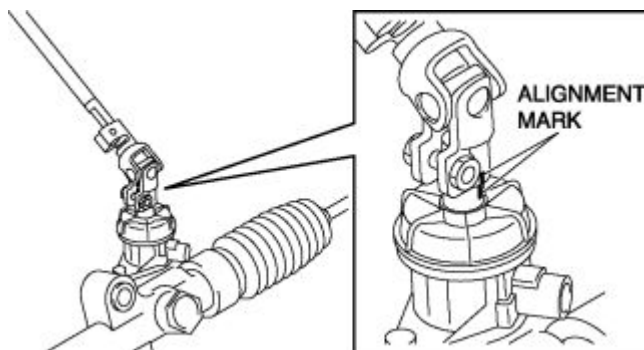

2. Loosen the joint upper bolt.
3. Remove the joint lower bolt and detach the intermediate shaft from the steering gear.

### Steering Lock Mounting Bolt Removal Note

1. Make a groove in the heads of the steering lock mounting bolts using a chisel and hammer.

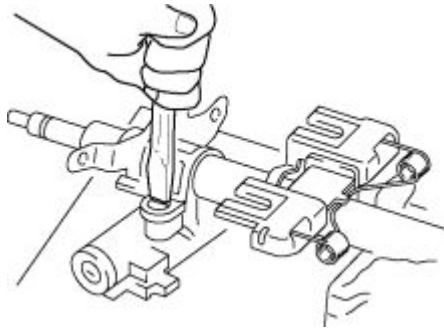

2. Remove the bolts using a flathead screwdriver.
3. Remove the steering lock.

### Steering Lock Mounting Bolt Installation Note

1. Assemble the steering lock to the steering shaft.
2. Verify the operation condition of the steering lock system.
3. Install new steering lock mounting bolts.
4. Tighten the bolts until the heads break off.

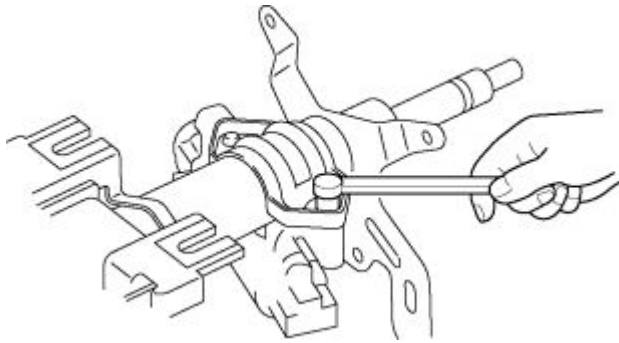

### Steering Shaft Installation Note

1. Verify that the tilt lever is in the LOCK position.
2. Temporarily tighten nuts A and B as shown in the figure.

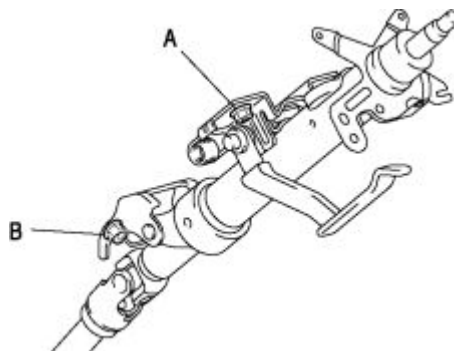

3. Tighten the nuts to the specified torque in the order of A, B.

### Tightening torque

- 15.7—22.5 N·m  
{1.60—2.29 kgf·m, 11.6—16.5 ft·lbf}

### **Bolt (Intermediate Shaft) Installation Note**

1. Align the marks made during removal and install the steering shaft to the steering gear.

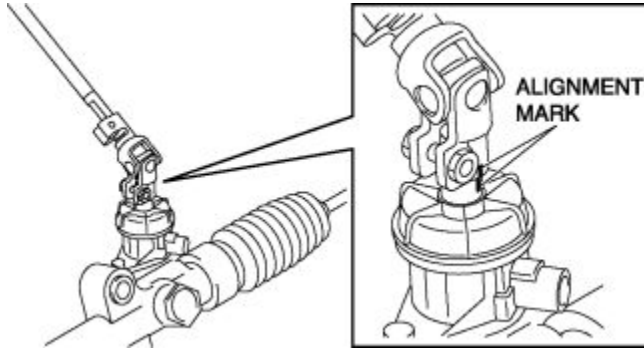

2. Tighten the joint bolts (lower and upper).

#### **Tightening torque**

- 17.6—26.5 N·m  
{1.80—2.70 kgf·m, 13.0—19.5 ft·lbf}

3. After tightening the bolts, move the intermediate shaft joint up and down and verify that it is securely installed.

### **Steering Wheel Installation Note**

1. Set the wheels in the straight-ahead position, and install the steering wheel.



# STEERING SHAFT

## STEERING SHAFT INSPECTION

1. Inspect the column bearing for excessive play and damage.
2. Verify that the measurement of the steering shaft is as specified in the figure.

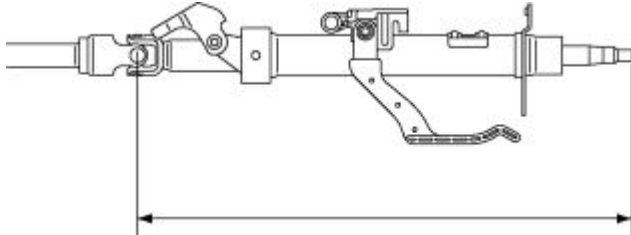

If not within the specification, replace the steering shaft component.

### Standard

- o 508.5 mm {20.02 in}
3. Inspect the tilt function operation for the following.

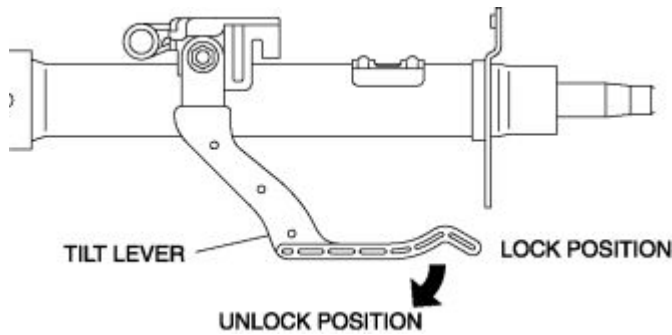

- a. Verify that the tilt lever moves smoothly from the lock to the unlock position.
- a. Verify that the steering shaft is fixed firmly when the tilt lever is locked.  
If there is any malfunction, replace the steering shaft.

# STEERING GEAR AND LINKAGE

## STEERING GEAR AND LINKAGE REMOVAL/INSTALLATION

### CAUTION:

Performing the following procedures without first removing the ABS wheel-speed sensor may possibly cause an open circuit in the wiring harness if it is pulled by mistake. Before performing the following procedures, remove the ABS wheel-speed sensor harness (axle side) and fix it to an appropriate place where the harness will not be pulled by mistake while servicing the vehicle.

After replacing the steering gear and linkage, always set the EPS system to the neutral position to prevent system malfunction. (See EPS SYSTEM NEUTRAL POSITION SETTING .)

1. Remove the under cover.
2. Remove in the order indicated in the table.
3. Install in the reverse order of removal.
4. After installation, inspect the front wheel alignment and adjust it if necessary. (See FRONT WHEEL ALIGNMENT .)
5. Set the EPS system to the neutral position. (See EPS SYSTEM NEUTRAL POSITION SETTING .)

Notes:

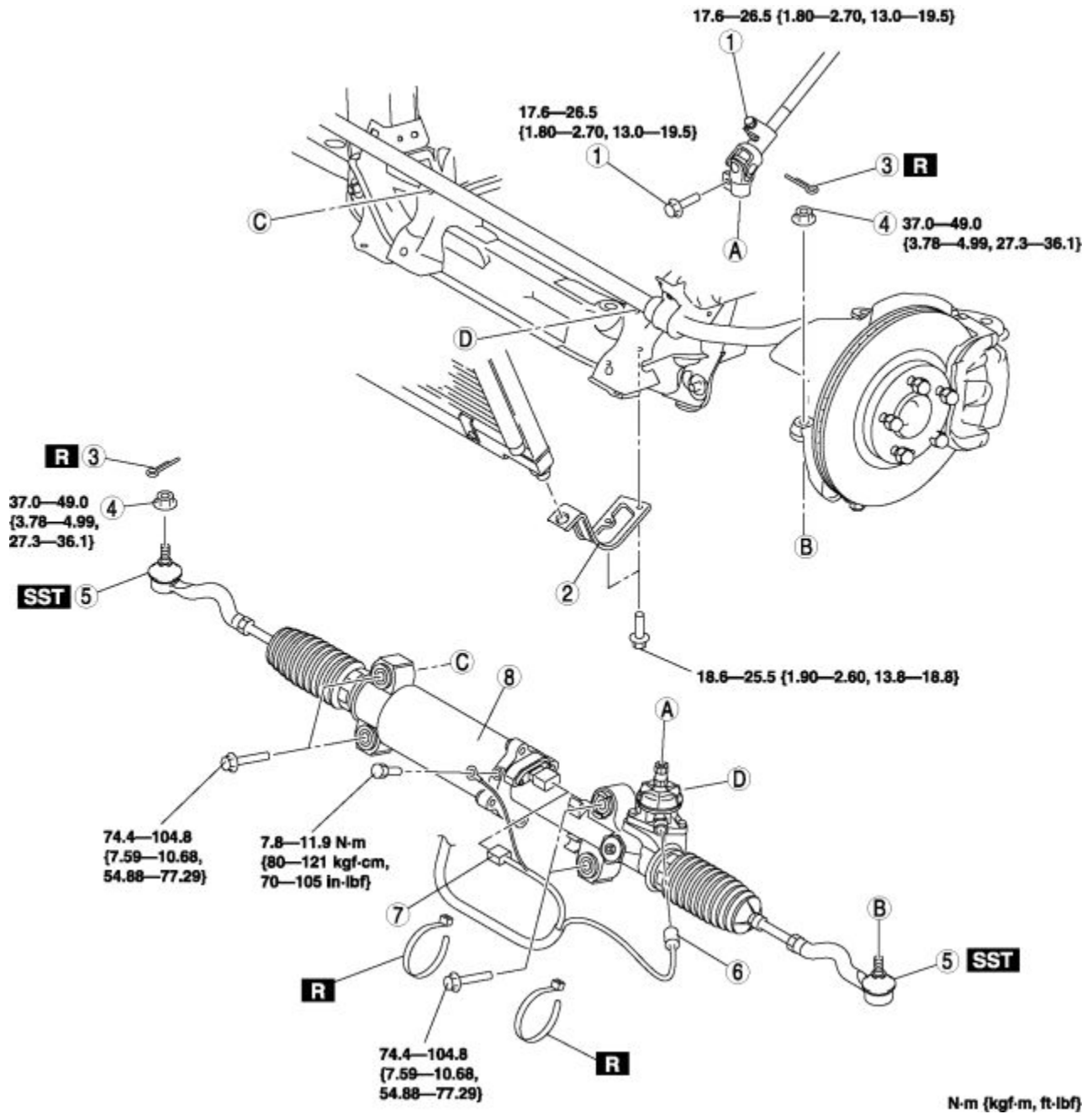

	Bolt (intermediate shaft)
1	(See Bolt (Intermediate Shaft) Removal Note .) (See Bolt (Intermediate Shaft) Installation Note .)
2	Radiator bracket
3	Cotter pin
4	Locknut (tie-rod end)
5	Tie-rod end (See Tie-rod End Removal Note .)
6	Torque sensor connector

7	EPS motor connector
8	Steering gear and linkage (See Steering Gear and Linkage Installation Note .)

### Tie-rod End Removal Note

1. Remove the outer ball joint locknut.
2. Detach the outer ball joint from the steering knuckle using the SST .

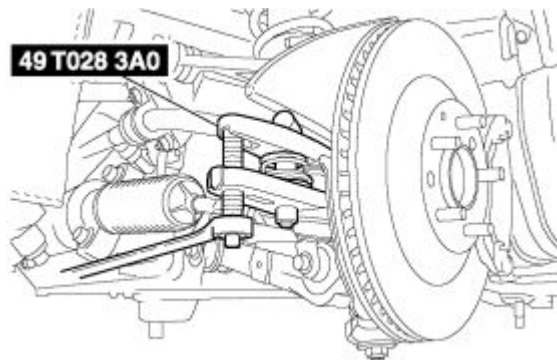

### Steering Gear and Linkage Installation Note

1. Temporarily tighten the bolts.
2. Tighten the steering gear and linkage installation bolts to the specified torque in the order shown in the figure.

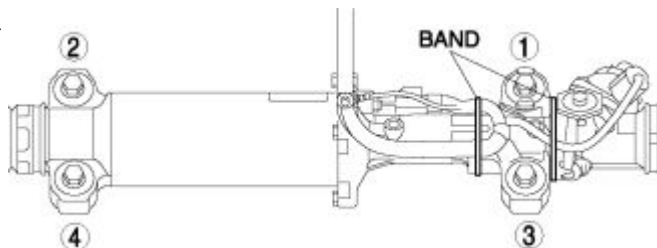

#### Tightening torque

- 74.4—104.8 N·m  
{7.59—10.68 kgf·m, 54.88—77.29 ft·lbf}

3. After connecting the connector, fix the wiring harness with the bands as shown in the figure.

## STEERING GEAR AND LINKAGE INSPECTION

### Tie-rod End Inspection

1. Inspect the tie-rod end for damage and excessive play.  
If there are any cracks, replace the tie-rod end.
2. Inspect the boot for cracks.  
If there is any malfunction, replace the tie-rod end boot.

3. Rotate the ball joint **5 times** .
4. Measure the rotational torque of the tie-rod end using the **SST** and a pull scale.

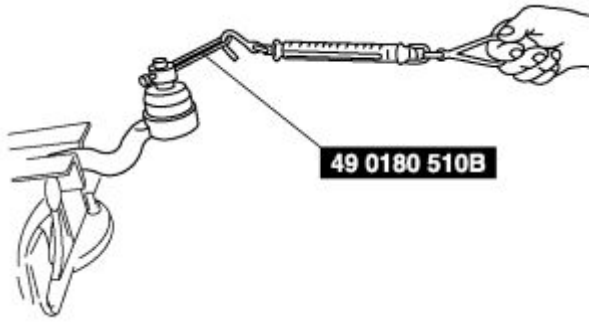

If not within the specification, replace the tie-rod end.

#### **Standard rotational torque**

- 0.6—2.0 N·m {6—20 kgf·cm, 5—17 in·lbf}

#### **Pull scale reading**

- 5.9—19.6 N {0.61—1.99 kgf, 1.33—4.40 lbf}

### **Tie rod Inspection**

1. Inspect for damage, bending and excessive play.  
If there is any malfunction, replace the steering gear and linkage.
2. Swing the ball joint **5 times** .
3. Measure the swing torque using a pull scale.

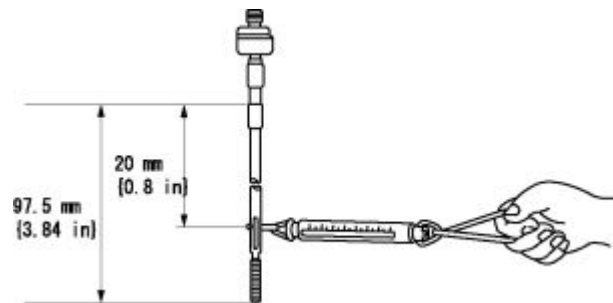

If it exceeds the specification, replace the steering gear and linkage.

#### **Standard swing torque**

- 0.68—2.45 N·m  
{7.0—24.9 kgf·cm, 6.1—21.6 in·lbf}

#### **Pull scale reading**

- 6.8—24.5 N {0.70—2.49 kgf, 1.53—5.50 lbf}

## STEERING GEAR AND LINKAGE DISASSEMBLY/ASSEMBLY

1. Disassemble in the order indicated in the table.
2. Assemble in the reverse order of disassembly.

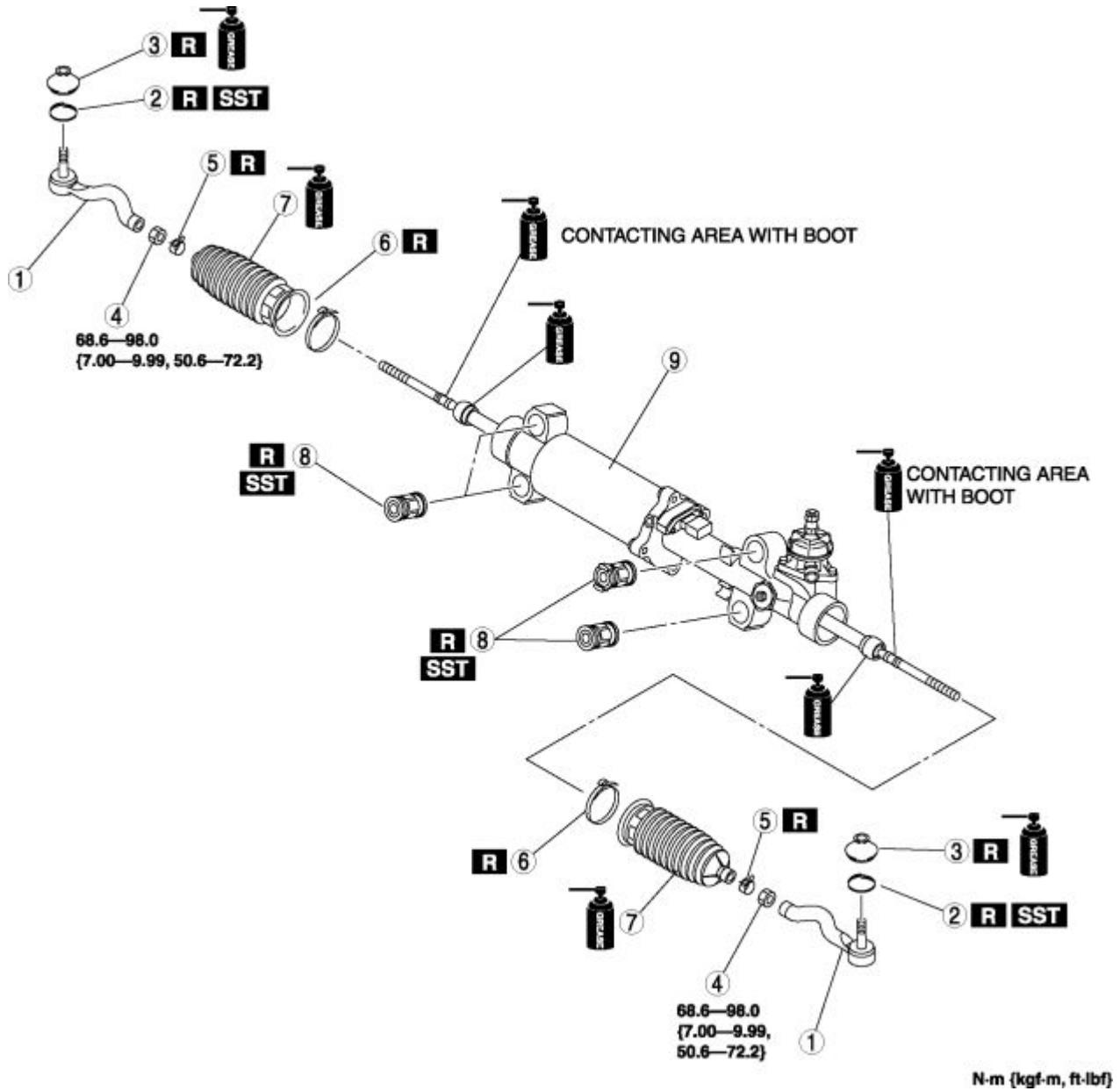

1	Tie-rod end (See Tie-rod End Disassembly Note .)
2	Clip (See Clip Assembly Note .)
3	Tie-rod end boot
4	Locknut
5	Boot clamp
6	Boot band

	(See Boot Band Assembly Note .)
7	Boot
	Mounting rubber
8	(See Mounting Rubber Disassembly Note .)
	(See Mounting Rubber Assembly Note .)
9	Steering gear and linkage

### Tie-rod End Disassembly Note

1. Place alignment marks as shown in the figure for proper installation.

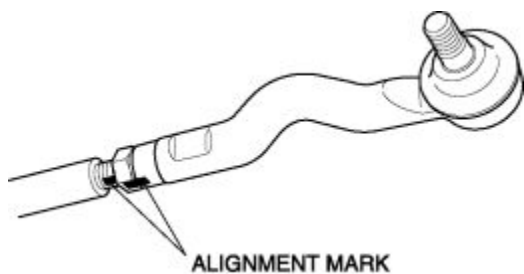

2. Remove the tie-rod end.

### Mounting Rubber Disassembly Note

1. Press the mounting rubber out from the gear housing using the SSTs and a press.

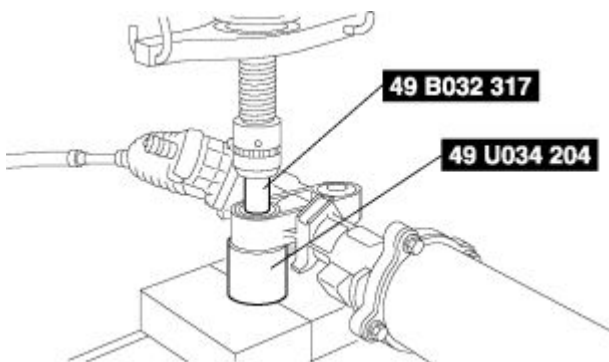

### Mounting Rubber Assembly Note

1. Apply soapy water to the rubber part of the mounting rubber.
  2. Press the mounting rubber until the mounting rubber end comes out completely from the gear housing using the SSTs and a press.
- 
3. Reverse the gear housing, then press the mounting rubber until the mounting rubber end comes out completely from the other side. At this time, verify that the mounting rubber and steel pipe are aligned.

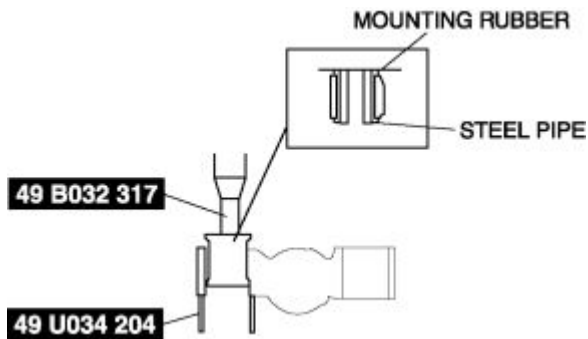

### Boot Band Assembly Note

1. Crimp the boot band using the **SST** .

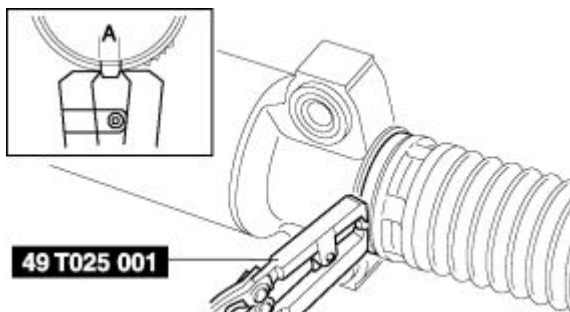

2. Verify that the crimping clearance **A** is within the specification.  
 If crimping clearance **A** exceeds the specification, reduce **SST** clearance, and crimp the boot band again.  
 If crimping clearance **A** is less than the specification, increase **SST** clearance, and crimp a new boot band.

#### Standard clearance **A**

- 2—3 mm {0.08—0.11 in}
3. Rotate the boot by hand and verify that it is securely installed to the boot band.

### Clip Assembly Note

1. Wipe off the old grease from the ball stud.
2. Fill the inside of the new dust boot with grease.
3. Install the dust boot on the ball joint.
4. Install the clip using the **SST** .

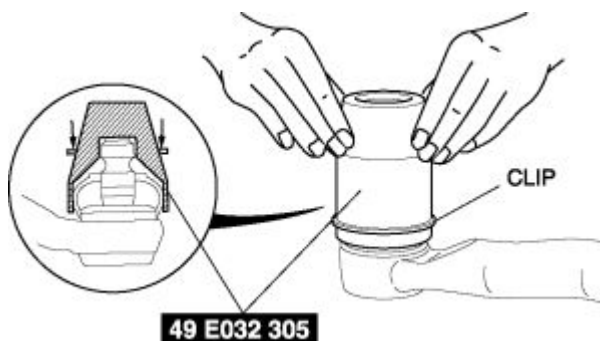



5. Verify that the clip is installed securely to the groove.
6. Wipe off any excess grease.

## STEERING GEAR AND LINKAGE ADJUSTMENT

1. Remove the locknut using the SST .

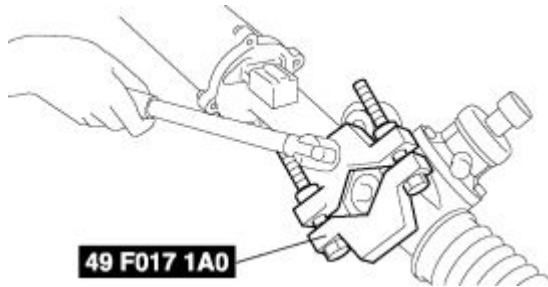

2. Apply sealant to the threads of the adjustment cover.
3. Tighten the adjustment cover to **20—29 N·m {2.1—2.9 kgf·cm, 15—21 in·lbf}** .
4. After swinging the steering rack left and right **10 times** , tighten the adjustment cover again to **5.8 N·m {59 kgf·cm, 51 in·lbf}** .
5. Loosen the adjustment cover **10—20** .

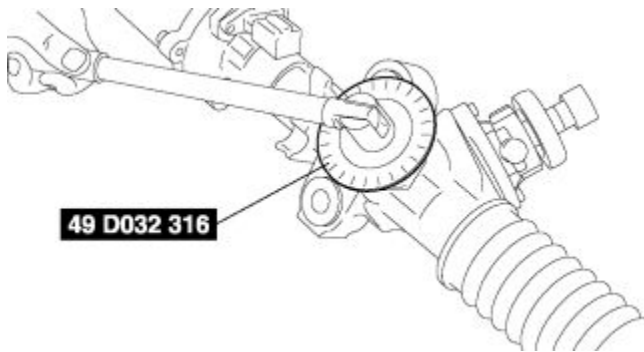

6. Lock the adjustment cover against rotation and tighten the locknut using the SST .

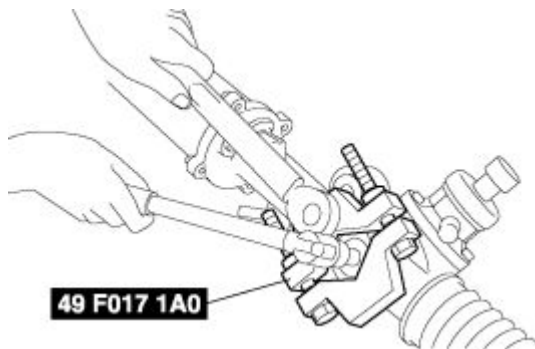

### Tightening torque

- **20—29 N·m {2.1—2.9 kgf·cm, 15—21 in·lbf}**
7. Measure the pinion shaft rotational torque using the SST and a pull scale.



If not within the specification, repeat from Steps 1—6.

### Standard rotational torque

- 1.2—2.0 N·m {13—20 kgf·cm, 11—17 in·lbf}

### Pull scale reading

- 11.2—20.0 N {1.15—2.03 kgf, 2.52—4.48 lbf}

## TORQUE SENSOR INSPECTION

1. Measure the resistance between torque sensor connector terminals A and B, and B and C.

### TORQUE SENSOR CONNECTOR



If there is any malfunction, replace the steering gear and linkage.

### Standard

- A—B: 12—15 ohms
- B—C: 12—15 ohms

# ELECRIC POWER STEERING CONTROL MODULE

## EPS CONTROL MODULE REMOVAL/INSTALLATION

### CAUTION:

If the EPS control module is replaced, set the EPS system to the neutral position. If not set to the neutral position, the system may not operate correctly. (See EPS SYSTEM NEUTRAL POSITION SETTING .)  
Do not drop the EPS control module. Replace the EPS control module if it subjected to an impact.

1. Remove the engine cover, battery cover, and PCM cover.

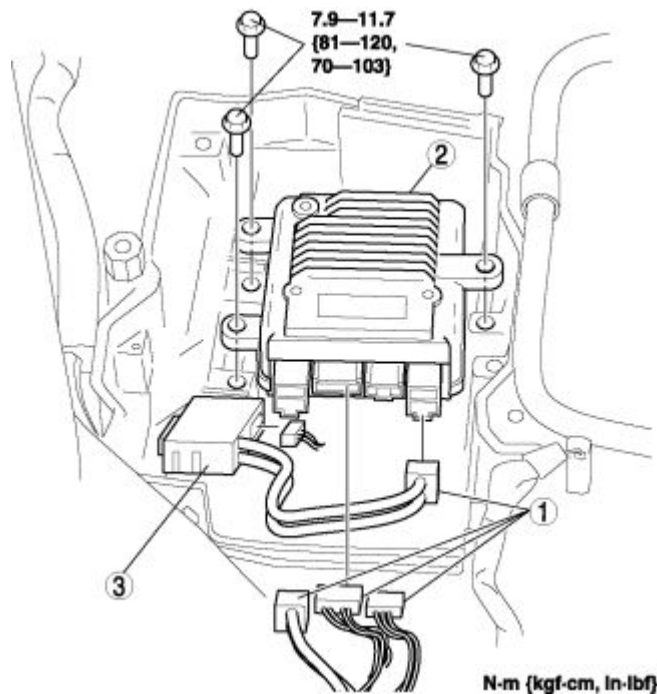

2. Remove the PCM. (See PCM REMOVAL/INSTALLATION .)
3. Remove in the order indicated in the table.
4. Install in the reverse order of removal.
5. After installation, set the EPS system to the neutral position. (See EPS SYSTEM NEUTRAL POSITION SETTING .)

1	Connector
2	EPS control module
3	Noise filter

## EPS CONTROL MODULE INSPECTION

1. Remove the engine cover, battery cover, and PCM cover.
2. Remove the PCM and the EPS control module. (See EPS CONTROL MODULE REMOVAL/INSTALLATION .)
3. Connect the PCM and EPS control module connectors.
4. Attach the tester lead to the underside of the control module connector and inspect the voltage and continuity according to the Terminal Voltage Table (Reference) indicated in the table.

### NOTE:

When inspecting the torque sensor and EPS motor for continuity, turn the ignition switch off and inspect with the connectors for the EPS control module, torque sensor, and EPS motor disconnected.

### Terminal Voltage Table (Reference)

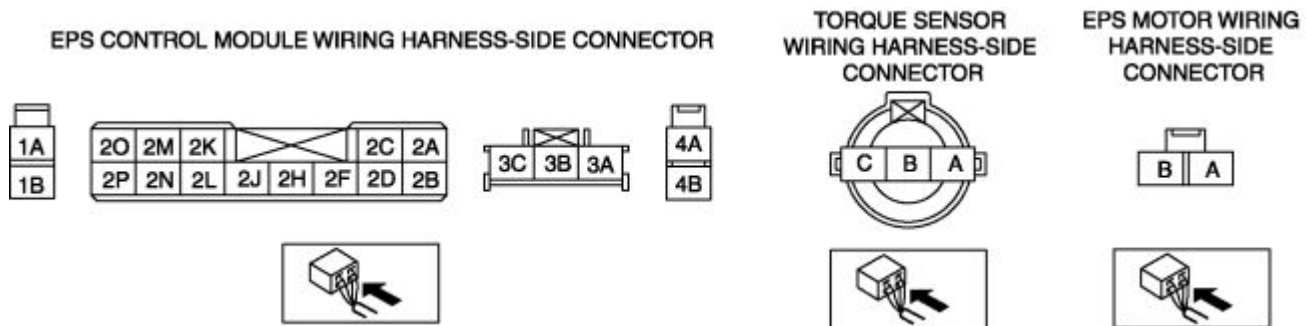

Terminal	Signal name	Connected to	Measured item	Measured terminal (measured condition)	Standard	Inspection item(s)
1A	Battery power supply	Battery	Voltage	Under any condition	B+	Wiring harness (1A—battery) Fuse (60 A)
1B	Ground	Ground point	Voltage	Under any condition	1 V or less	Wiring harness (1B—ground point)
2A	Ground	Ground point	Voltage	Under any condition	1 V or less	Wiring harness (2A—ground point)
2B	—	—	—	—	—	—
2C	—	—	—	—	—	—

2D	—	—	—	—	—	—
2E	—	—	—	—	—	—
2F	—	—	—	—	—	—
2H	—	—	—	—	—	—
2J	—	—	—	—	—	—
2K	CAN-L	—	Inspect under DTC inspection.			—
2L	—	—	—	—	—	—
2M	CAN-H	—	Inspect under DTC inspection.			—
2N	—	—	—	—	—	—
2O	Ground	Ground point	Voltage	Under any condition	1 V or less	Wiring harness (2O—ground point)
2P	Ignition power supply	Ignition switch	Voltage	Ignition switch is ON	B+	Wiring harness (2P—ignition switch—battery) Fuse (15 A)
				Ignition switch is OFF	1 or less	
3A	Torque sensor (Signal 2)	Torque sensor	Continuity	Terminal 3A—torque sensor terminal A	Continuity detected	Wiring harness (3A—torque sensor A)
3B	Torque sensor (Drive signal)	Torque sensor	Continuity	Terminal 3B—torque sensor terminal B	Continuity detected	Wiring harness (3B—torque sensor B)
3C	Torque sensor (Signal 1)	Torque sensor	Continuity	Terminal 3C—torque sensor terminal C	Continuity detected	Wiring harness (3C—torque sensor C)
4A	EPS motor	EPS motor	Continuity	Terminal 4A—EPS motor terminal A	Continuity detected	Wiring harness (4A—EPS motor

						A)
4B	EPS motor	EPS motor	Continuity	Terminal 4B—EPS motor terminal B	Continuity detected	Wiring harness (4B—EPS motor B)

## EPS SYSTEM NEUTRAL POSITION SETTING

1. Set the front wheels in the straight-ahead position. (Steering wheel is within **45** to the left or right of center position.)
2. Jack up both front tires so that there is no weight on them.
3. Lower the jack until the front tires touch the ground. At this time, be careful not to touch the tires or the steering wheel.
4. Connect the WDS or equivalent to the DLC-2.

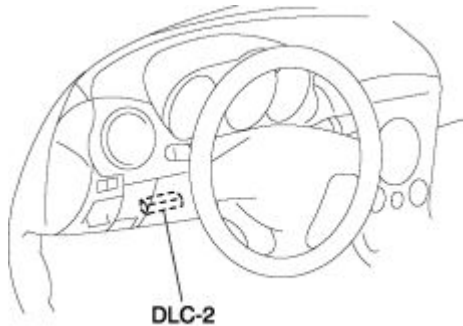

5. Set to neutral by selecting the TRQ\_S\_CAL active command mode function.
6. After setting to neutral, start the engine, rotate the steering wheel slowly in both directions within a range of **90** , and verify that the steering force does not differ in either directions.  
If the steering force is different in either direction, inspect the power steering system following a separate troubleshooting procedure. (See NO.3 POWER ASSIST DIFFERS BETWEEN RIGHT AND LEFT TURNS .)

# GENERAL PROCEDURES

## STEERING

### GENERAL PROCEDURES (STEERING)

#### Wheel And Tire Installation

1. When installing the wheels and tires, tighten the wheel nuts in a criss-cross pattern to the following tightening torque.

#### **Tightening torque**

- 88—118 N·m  
{9.0—12.0 kgf·m, 65.0—87.0 ft·lbf}

#### Connectors Disconnection

1. Disconnect the negative battery cable before performing any work that requires handling of connectors.

#### EPS Related Parts

1. Make sure that there are no DTCs in the EPS memory after working on EPS related parts. If there are any codes in the memory, clear them.

#### EPS System Neutral Setting

#### CAUTION:

After working on the steering system, always set the EPS system to the neutral position to prevent system malfunction.

1. After performing the following, set the EPS system to the neutral position. (See EPS SYSTEM NEUTRAL POSITION SETTING .)
  - Steering gear and linkage replacement
  - EPS control unit replacement
  - Disconnecting the steering shaft joint (gear side)

# SYMPTOM TROUBLESHOOTING

## ELECTRIC POWER STEERING

### ELECTRIC POWER STEERING (EPS) SYSTEM WIRING DIAGRAM

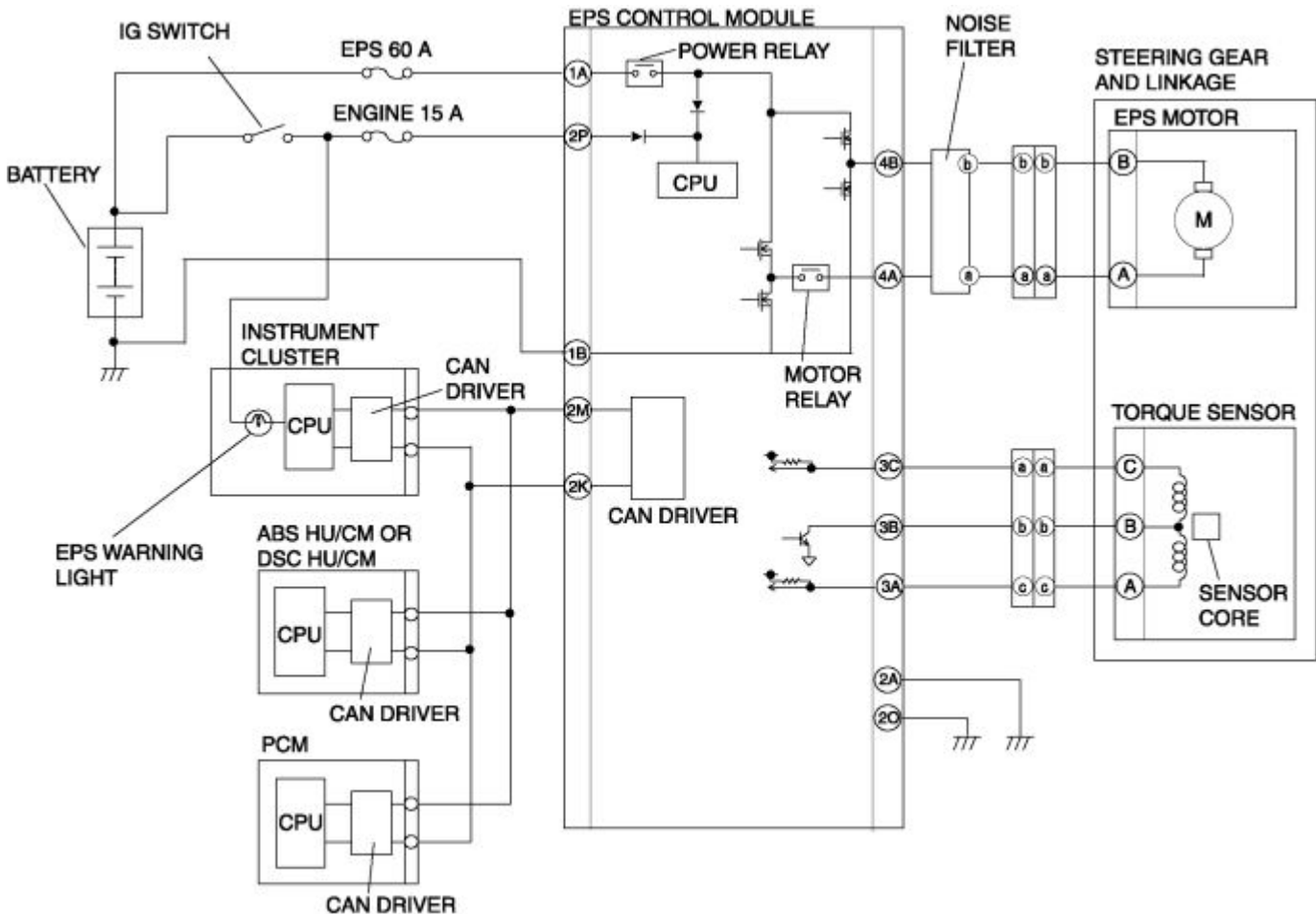

## FOREWORD

Before performing the steps in Symptom Troubleshooting, perform the On-board Diagnostic Inspection. To inspect the DTC, follow the DTC Inspection steps. (See DTC Table .)

## PRECAUTION

### Intermittent Concern Troubleshooting

#### Vibration method

If a malfunction occurs or becomes worse while driving on a rough road or when the engine is vibrating, perform the following steps.

#### NOTE:



There are several reasons why vehicle or engine vibration could cause an electrical malfunction. Inspect the following:

- Connectors not fully seated.
- Wiring harnesses not having full play.
- Wires laying across brackets or moving parts.
- Wires routed too close to hot parts.

An improperly routed, improperly clamped, or loose harness can cause wiring to become pinched between parts.

The connector joints, points of vibration, and places where wiring harnesses pass through the firewall, body panels and other panels are the major areas to be inspected.

#### **Inspection method for switch and/or sensor connectors or wires**

1. Connect the WDS or equivalent to the DLC-2.
2. Turn the ignition switch to the ON position (engine off).

#### **NOTE:**

If the engine starts and runs, perform the following steps at idle.

3. Access PIDs for the switch you are inspecting.
4. Turn the switch on manually.
5. Slightly shake each connector or wiring harness vertically and horizontally while monitoring the PID.

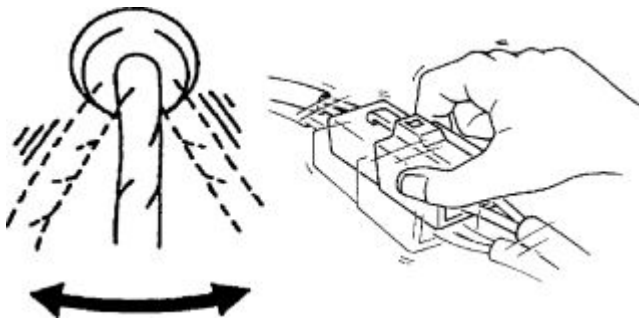

If the PID value is unstable, inspect for poor connection.

#### **Inspection method for sensors**

1. Connect the WDS or equivalent to the DLC-2.

- Turn the ignition switch to the ON position (engine off).

**NOTE:**

If the engine starts and runs, perform the following steps at idle.

- Access PIDs for the switch you are inspecting.
- Vibrate the sensor slightly with your finger.  
If the PID value is unstable or a malfunction occurs, inspect for poor connection and/or poorly mounted sensor.

**Connector terminal check method**

- Inspect the connection of each female terminal.
- Insert the male terminal and then fit the female terminal side to female terminal. Inspect whether the malfunction is in the female terminal.

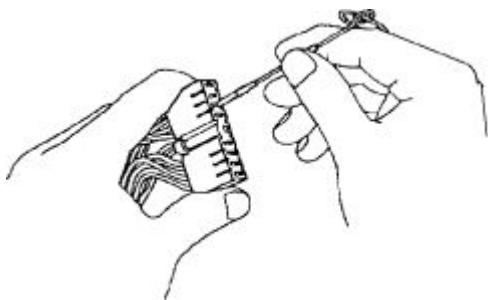

**SYMPTOM TROUBLESHOOTING**

Verify the symptom, and perform troubleshooting according to the appropriate number.

No.	Symptom
1	EPS warning light does not illuminate with ignition switch at ON.
2	EPS warning light does not go out even though engine has started.
3	Power assist differs between right and left turns.

# NO.1 ELECTRIC POWER STEERING (EPS) WARNING LIGHT DOES NOT ILLUMINATE WITH IGNITION SWITCH AT ON

<b>1</b>	<b>EPS warning light does not illuminate with ignition switch at ON.</b>
<b>TROUBLESHOOTING HINTS</b>	
<p>EPS warning light circuit malfunction in the instrument cluster            An error originates from the EPS control module, and the "off" signal is generated.</p> <ul style="list-style-type: none"> <li>▪ EPS control module malfunction</li> </ul>	

Diagnostic procedure

STEP	INSPECTION		ACTION
1	<b>INSPECT PID/DATA IN EPS CONTROL MODULE</b>  Select the following items using the WDS or equivalent Datalogger function. <ul style="list-style-type: none"> <li>▪ EPSLAMP (EPS warning light)</li> </ul> Is the EPSLAMP ON while the ignition switch is turned to the ON position?	Yes	EPS warning light circuit malfunction in the instrument cluster. Inspect the instrument cluster.  (See INSTRUMENT CLUSTER INPUT/OUTPUT CHECK MODE .)
		No	EPS control module malfunction. Replace the EPS control module.  (See EPS CONTROL MODULE REMOVAL/INSTALLATION .)

## NO.2 ELECTRIC POWER STEERING (EPS) WARNING LIGHT DOES NOT GO OUT EVEN THOUGH ENGINE HAS STARTED

<b>2</b>	<b>EPS warning light does not go out even though engine has started.</b>
<b>TROUBLESHOOTING HINTS</b>	
<p>EPS system malfunction</p> <ul style="list-style-type: none"> <li>▪ Wiring harness malfunction</li> <li>▪ Connector condition malfunction</li> <li>▪ Torque sensor malfunction</li> <li>▪ EPS motor malfunction</li> <li>▪ Fuse malfunction</li> <li>▪ EPS control module malfunction</li> </ul> <p>EPS control module detects an EPS system malfunction even though the EPS system is normal.</p> <p>CAN communication line malfunction</p> <ul style="list-style-type: none"> <li>▪ Vehicle speed signal malfunction</li> <li>▪ Engine speed signal malfunction</li> <li>▪ CAN wiring harness malfunction</li> </ul> <p>EPS warning light circuit malfunction in the instrument cluster</p> <p>CAN wiring harness malfunction</p> <ul style="list-style-type: none"> <li>▪ Malfunction in wiring harness between EPS control module and instrument cluster</li> </ul>	

### Diagnostic procedure

STEP	INSPECTION		ACTION
1	INSPECT EPS CONTROL MODULE AND DLC-2 FOR CONTINUITY OR SHORT  Perform the DTC inspection. Is an error message regarding the communication between the EPS control module and the WDS or equivalent displayed?	Yes	If a communication error message is displayed even after inspecting according to the procedures displayed on the WDS or equivalent, go to Step 5.
		No	Go to the next step.
2	INSPECT FOR DTCS IN EPS CONTROL MODULE  Have DTCS been recorded in the memory?	Yes	Perform inspection using the appropriate DTC.
		No	Go to the next step.

3	<p>INSPECT PID/DATA IN EPS CONTROL MODULE</p> <p>Select the following items using the WDS or equivalent Datalogger function.</p> <ul style="list-style-type: none"> <li>▪ EPSLAMP (EPS warning light)</li> </ul> <p>Is the EPSLAMP ON after the engine is already running?</p>	Yes	<p>Repeat the DTC inspection. If no DTCs have been recorded in the memory, replace the EPS control module.</p> <p>(See EPS CONTROL MODULE REMOVAL/INSTALLATION .)</p>
		No	<p>The EPS system is normal. Go to the next step.</p>
4	<p>INSPECT WIRING HARNESS FOR CONTINUITY BETWEEN EPS CONTROL MODULE AND INSTRUMENT CLUSTER</p> <p>Disconnect the EPS control module connector and the instrument cluster connector.</p> <p>Inspect for continuity between the EPS control module and the instrument cluster at the following terminals.</p> <ul style="list-style-type: none"> <li>▪ Terminal 2M (13-pin) and terminal 1J (12-pin)</li> <li>▪ Terminal 2K (13-pin) and terminal 1L (12-pin)</li> </ul> <p>Is there continuity?</p>	Yes	<p>Inspect the instrument cluster. (EPS warning light circuit malfunction in the instrument cluster)</p> <p>(See INSTRUMENT CLUSTER INPUT/OUTPUT CHECK MODE .)</p>
		No	<p>Repair the wiring harness between the EPS control module and the instrument cluster, then reinspect the malfunction symptoms.</p>
5	<p>INSPECT WIRING HARNESS FOR CONTINUITY BETWEEN EPS CONTROL MODULE AND DLC-2</p> <p>Disconnect the EPS control module connector.</p> <p>Inspect for continuity between the EPS control module and the DLC-2 at the following terminals.</p> <ul style="list-style-type: none"> <li>▪ Terminal 2M (13-pin) and CAN_H terminal (16-pin)</li> <li>▪ Terminal 2K (13-pin) and CAN_L terminal (16-pin)</li> </ul> <p>Is there continuity?</p>	Yes	<p>Go to the next step.</p>
		No	<p>Repair the wiring harness between the EPS control module and the DLC-2, then repeat from Step 1 if the malfunction.</p>

6	<p><b>INSPECT VOLTAGE AT EPS CONTROL MODULE</b></p> <p>Measure the voltage at EPS control module connector terminal 2P (13-pin, IG1 signal). Is the voltage within the following range?</p> <ul style="list-style-type: none"> <li>▪ IG ON: <b>10—16 V</b></li> </ul>	Yes	<p>Inspect the EPS control module connectors, then repeat from Step 1 if the malfunction recurs. If the same symptoms recur, replace the EPS control module.</p> <p>(See EPS CONTROL MODULE REMOVAL/INSTALLATION .)</p>
		No	<p>Inspect the battery. If the battery condition is normal, inspect and repair the EPS control module wiring harness (IG1 signal). Reinspect the malfunction symptoms.</p>

Notes:

## NO.3 POWER ASSIST DIFFERS BETWEEN RIGHT AND LEFT TURNS

<b>3</b>	<b>Power assist differs between right and left turns.</b>
<b>TROUBLESHOOTING HINTS</b>	
<p>Steering gear and linkage malfunction          EPS motor malfunction          Torque sensor malfunction          EPS control module malfunction          EPS system neutral position setting not performed.</p>	

### Diagnostic procedure

STEP	INSPECTION	ACTION
1	INSPECT FOR DTC IN EPS CONTROL MODULE	Yes Perform inspection using the appropriate DTC, then go to Step 3.
	Have DTCs been recorded in the memory?	No Go to the next step.
2	INSPECT STEERING WHEEL POWER ASSIST	Yes Inspect the steering gear and linkage. If it is abnormal, replace it. (See STEERING GEAR AND LINKAGE REMOVAL/INSTALLATION .)
	Disconnect the EPS motor connector. Inspect the steering wheel power assist. Is there a difference in the steering wheel power assist between right and left turns?	No Go to the next step.
3	INSPECT TORQUE SENSOR AND EPS MOTOR	Yes Inspect the torque sensor wiring harness and the EPS motor wiring harness. If they are normal, replace the EPS control module. (See EPS CONTROL MODULE REMOVAL/INSTALLATION .)
	Inspect the following items: <ul style="list-style-type: none"> <li>▪ Measure the resistance of the torque sensor.</li> </ul> <p style="text-align: center;"><b>Resistance: 12—15 ohms</b></p> <ul style="list-style-type: none"> <li>▪ Inspect the operating condition of the EPS motor.</li> </ul> Are they normal?	No Replace the steering gear and linkage. (See STEERING GEAR AND LINKAGE REMOVAL/INSTALLATION .)

# ON-BOARD DIAGNOSTIC

## ELECTRIC POWER STEERING

### ELECTRIC POWER STEERING (EPS) SYSTEM WIRING DIAGRAM

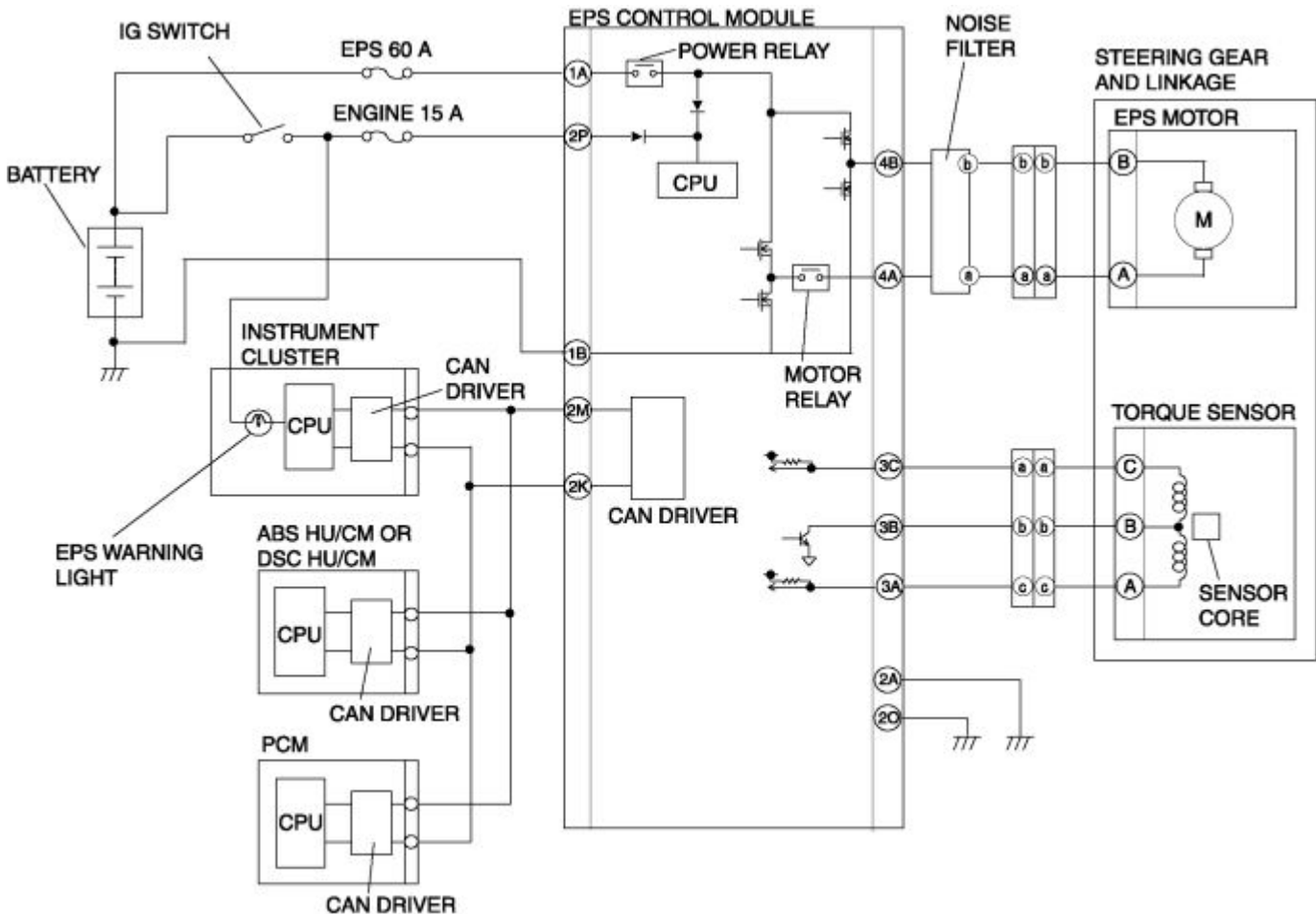

### ELECTRIC POWER STEERING (EPS) ON-BOARD DIAGNOSIS

#### On-Board Diagnostic (OBD) Test Description

The OBD test inspects the integrity and function of the EPS and outputs the results when requested by the specific tests.

On-board diagnostic test also:

- Provides a quick inspection of the EPS usually performed at the start of each diagnostic procedure.
- Provides verification after repairs to ensure that no other faults occurred during service.

The OBD test is divided into 3 tests:

- Read/clear diagnostic results, PID monitor and record and active command modes.

#### Read/clear diagnostic results

This function allows reading or clearing of DTCs in the EPS control module memory.



### **PID/Data monitor and record**

This function allows access of certain data values, input signals, calculated values, and system status information.

### **Active command modes**

This function allows control of devices through the WDS or equivalent.

### **Reading DTCs Procedure**

1. Connect the WDS or equivalent to the vehicle DLC-2 connector.

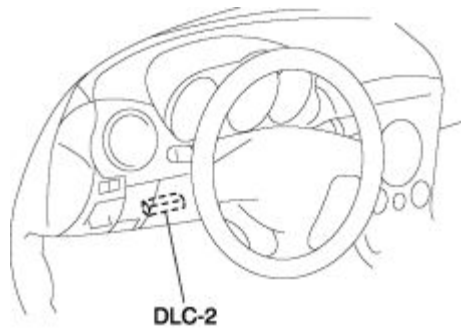

2. Retrieve DTCs using the WDS or equivalent.

### **Clearing DTCs Procedure**

1. After repairs have been made, perform the **Reading DTCs Procedure** .
2. Clear DTCs using the WDS or equivalent.
3. Verify that the customer's concern has been resolved.

### **PID/Data Monitor and Record Procedure**

1. Connect the WDS or equivalent to the vehicle DLC-2 connector.

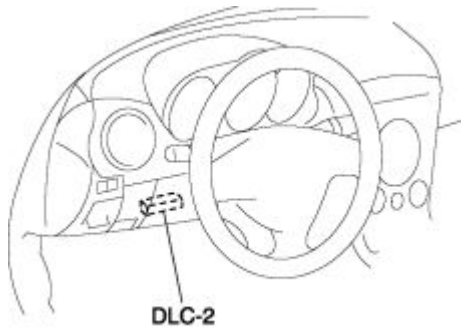

2. Access and monitor PIDs using the WDS or equivalent.

### Active Command Modes Procedure

1. Connect the WDS or equivalent to the vehicle DLC-2 connector.

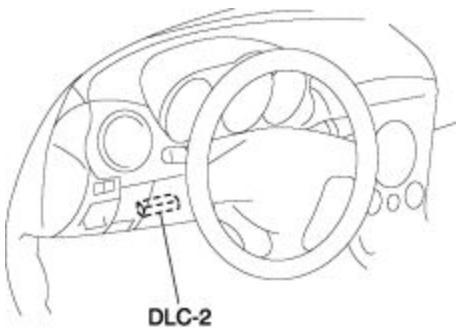

2. Activate active command modes using the WDS or equivalent.

### DTC Table

DTC	Diagnosis system component	Page
WDS or equivalent		
B1318	Battery power supply	(See DTC B1318 .)
B1342	EPS control module	(See DTC B1342 .)
B2141	EPS system (neutral position setting not performed)	(See DTC B2141 .)
B2278	Torque sensor	(See DTC B2278 .)

C1099	EPS motor	(See DTC C1099 .)
U0073	CAN bus communication error	(See MULTIPLEX COMMUNICATION SYSTEM .)
U1900	CAN communication error	(See MULTIPLEX COMMUNICATION SYSTEM .)
U2023	CAN communication error	(See MULTIPLEX COMMUNICATION SYSTEM .)

### PID/DATA Monitor Table

PID Name (Definition)	Unit/ Condition	Condition/Specification	Action	EPS control module terminal
B+ (System battery voltage value)	V	IG switch ON: <b>B+</b>	Inspect battery. (See BATTERY INSPECTION .) Inspect power supply circuit (such as IG switch, fuse).	2P
CCNT (Number of continuous codes)	—	DTCs are detected: <b>1—255</b> No DTCs are detected: <b>0</b>	Perform inspection using appropriate DTC.	—
EPS_MTR (EPS motor drive signal)	A	Steering wheel is not turned: <b>Near 0 A</b> Steering wheel is turned right: <b>0—127 A</b> Steering wheel is turned left: <b>0— -128 A</b>	Inspect EPS control module. (See EPS CONTROL MODULE INSPECTION .) Inspect EPS motor circuit. Inspect power supply circuit (such as IG switch, fuse).	4A, 4B
EPSLAMP (EPS warning light output state)	ON/OFF	EPS warning light is illuminated: ON EPS warning light is not illuminated: OFF	Inspect EPS control module. (See EPS CONTROL MODULE INSPECTION .) Inspect instrument cluster.	—
RPM (Engine speed signal)	RPM	Engine speed 1,000 rpm: <b>1000RPM</b>	Inspect PCM. (See PCM INSPECTION .)	—

		1000RPM		
TRQ_S_CORR (System neutral position setting)	NM	Steering wheel is not turned: <b>Near 0 NM</b>  (If system neutral position setting has not been performed, 31.75 NM is output.)	Perform EPS system neutral position setting. (See EPS SYSTEM NEUTRAL POSITION SETTING .)	—
TRQ_SENS (Torque sensor signal)	NM	Steering wheel is not turned: <b>Near 0 NM</b> Steering wheel is turned right: <b>0—31.75 NM</b> Steering wheel is turned left: <b>0— -32 NM</b>	Inspect torque sensor. (See TORQUE SENSOR INSPECTION .)  Inspect torque sensor circuit.	3A, 3B. 3C
VSS (Vehicle speed signal)	KPH/MPH	Vehicle is stopped: <b>0 KPH/0 MPH</b>  Vehicle speed 20 km/h {12 mph}: <b>20 KPH/12 MPH</b>	Inspect PCM. (See PCM INSPECTION .)  Inspect instrument cluster. (See INSTRUMENT CLUSTER INSPECTION .)  Inspect DSC HU/CM. (See DSC HU/CM INSPECTION .)	—

### Active Command Mode Table

Command Name	Definition	Operation	Note
TRQ_S_CAL	EPS system neutral position setting	ON/OFF	Ignition switch at ON

# DTC B1318

<b>DTC</b>	<b>B1318</b>	<b>Battery power supply</b>
<b>DETECTION CONDITION</b>	Voltage of <b>10 V or less</b> or <b>16 V or more</b> detected by EPS control module internal ignition voltage observation.	
<b>POSSIBLE CAUSE</b>	Short to ground in wiring harness between EPS control module terminal 2P and battery Battery malfunction Generator malfunction Poor connection of each connector	

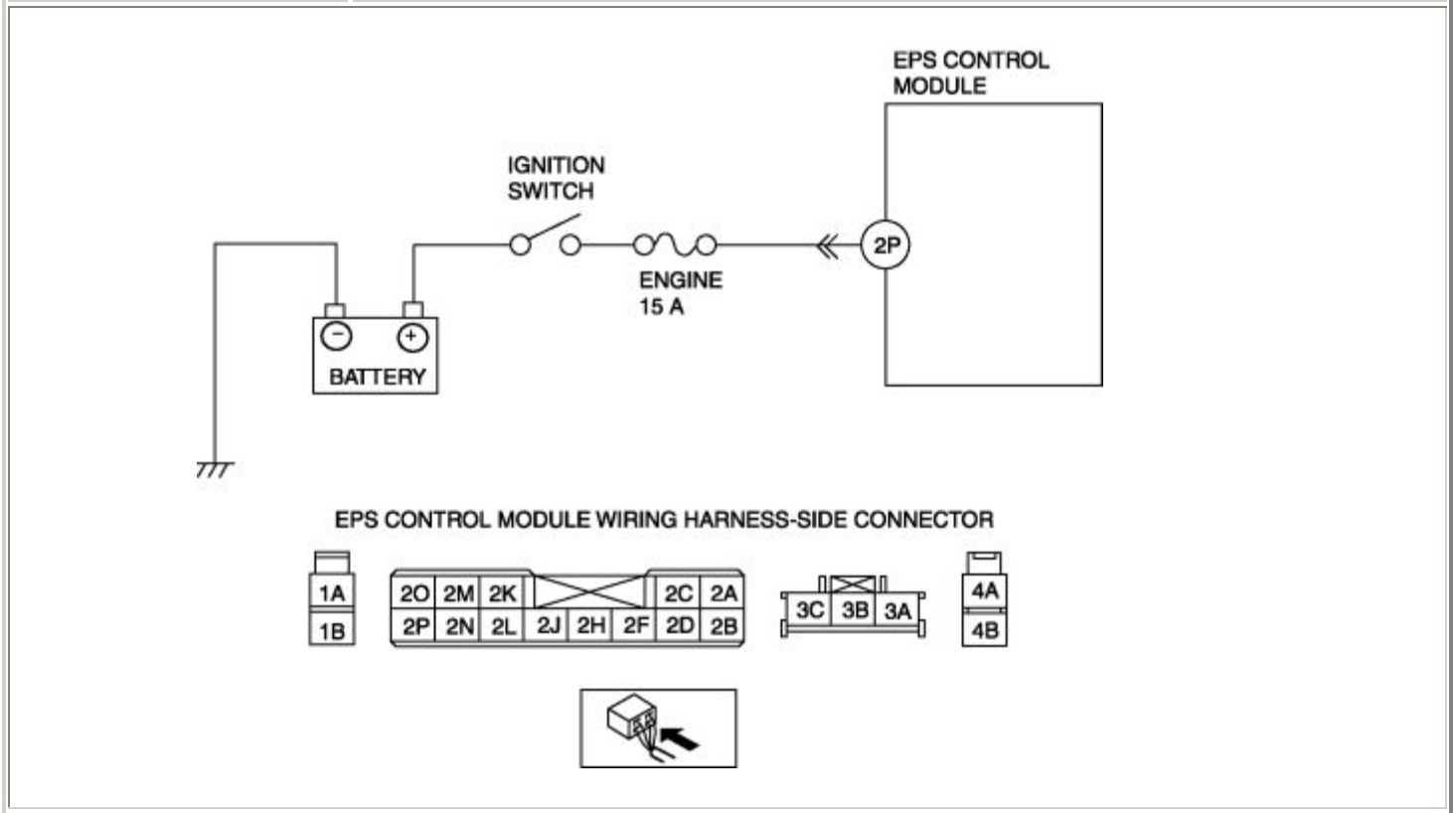

## Diagnostic procedure

STEP	INSPECTION	ACTION
1		Yes Malfunction may be temporary. Go to Step 6.

	<p><b>INSPECT POWER SUPPLY VOLTAGE USING WDS OR EQUIVALENT</b></p> <p>Turn the ignition switch off. Connect the WDS or equivalent to the DLC-2. Turn the ignition switch to the ON position (engine off). Access B+ PID. Is the voltage normal?</p>	No	Go to the next step.
2	<p><b>INSPECT BATTERY</b></p> <p>Inspect the battery.  (See BATTERY INSPECTION .)  Is it normal?</p>	Yes	Go to the next step.
		No	Repair or replace the battery, then go to Step 6.  (See BATTERY REMOVAL/INSTALLATION .)
3	<p><b>INSPECT GENERATOR</b></p> <p>Inspect the generator.  (See GENERATOR INSPECTION .)  Is it normal?</p>	Yes	Go to the next step.
		No	Repair or replace the generator, then go to Step 6.  (See GENERATOR REMOVAL/INSTALLATION .)
4	<p><b>INSPECT WHETHER MALFUNCTION IS CAUSED BY POOR CONNECTION OF EPS CONTROL MODULE OR PIN DEFORMATION</b></p> <p>Turn the ignition switch off. Inspect connection of the EPS control module and wiring harness. Disconnect the EPS control module connector. Inspect whether malfunction is caused by bent or poorly connected EPS control module connector pin. Are the connector connection, connector pins, and wiring harness normal?</p>	Yes	Go to the next step.
		No	Repair or replace the malfunction connector wiring harness, then go to Step 6.
5	<p><b>INSPECT EPS CONTROL MODULE POWER SUPPLY CIRCUIT FOR SHORT TO GROUND</b></p>	Yes	Repair or replace the wiring harness for short to ground between EPS control module terminal 2P and ground, then go to Step 6.

	<p>Disconnect the battery positive terminal.</p> <p>Inspect for continuity between EPS control module terminal 2P and ground.</p> <p>Is there continuity?</p>	No	Go to the next step.
6	<p>VERIFY TROUBLESHOOTING COMPLETED</p> <p>Make sure to reconnect all disconnected connectors.</p> <p>Clear the DTC from the memory.</p> <p>(See Clearing DTCs Procedure .)</p> <p>Turn the ignition switch off.</p> <p>Start the engine.</p> <p>Is the same DTC present?</p>	Yes	<p>Replace the EPS control module, then go to the next step.</p> <p>(See EPS CONTROL MODULE REMOVAL/INSTALLATION .)</p>
		No	Go to the next step.
7	<p>VERIFY AFTER REPAIR PROCEDURE</p> <p>Are any other DTCs present?</p>	Yes	<p>Go to the applicable DTC inspection.</p> <p>(See DTC Table .)</p>
		No	DTC troubleshooting completed.

Notes:

## DTC B1342

DTC	B1342	EPS control module
<b>DETECTION CONDITION</b>	The on-board diagnostic function detects control module malfunction.	
<b>POSSIBLE CAUSE</b>	<p>Open or short to ground circuit in wiring harness between EPS control module terminal 1A and battery positive terminal.</p> <p>Open or short circuit in wiring harness between the following EPS control module terminals and EPS motor terminals:</p> <ul style="list-style-type: none"><li>▪ EPS control module terminal 4A—EPS motor terminal A</li><li>▪ EPS control module terminal 4B—EPS motor terminal B</li></ul> <p>Open circuit in wiring harness between EPS control module terminal 1B and battery negative terminal</p> <p>EPS control module malfunction</p> <p>EPS motor malfunction</p> <p>EPS 60 A fuse malfunction</p> <p>Noise filter malfunction</p> <p>Poor connection of each connector</p>	

Notes:



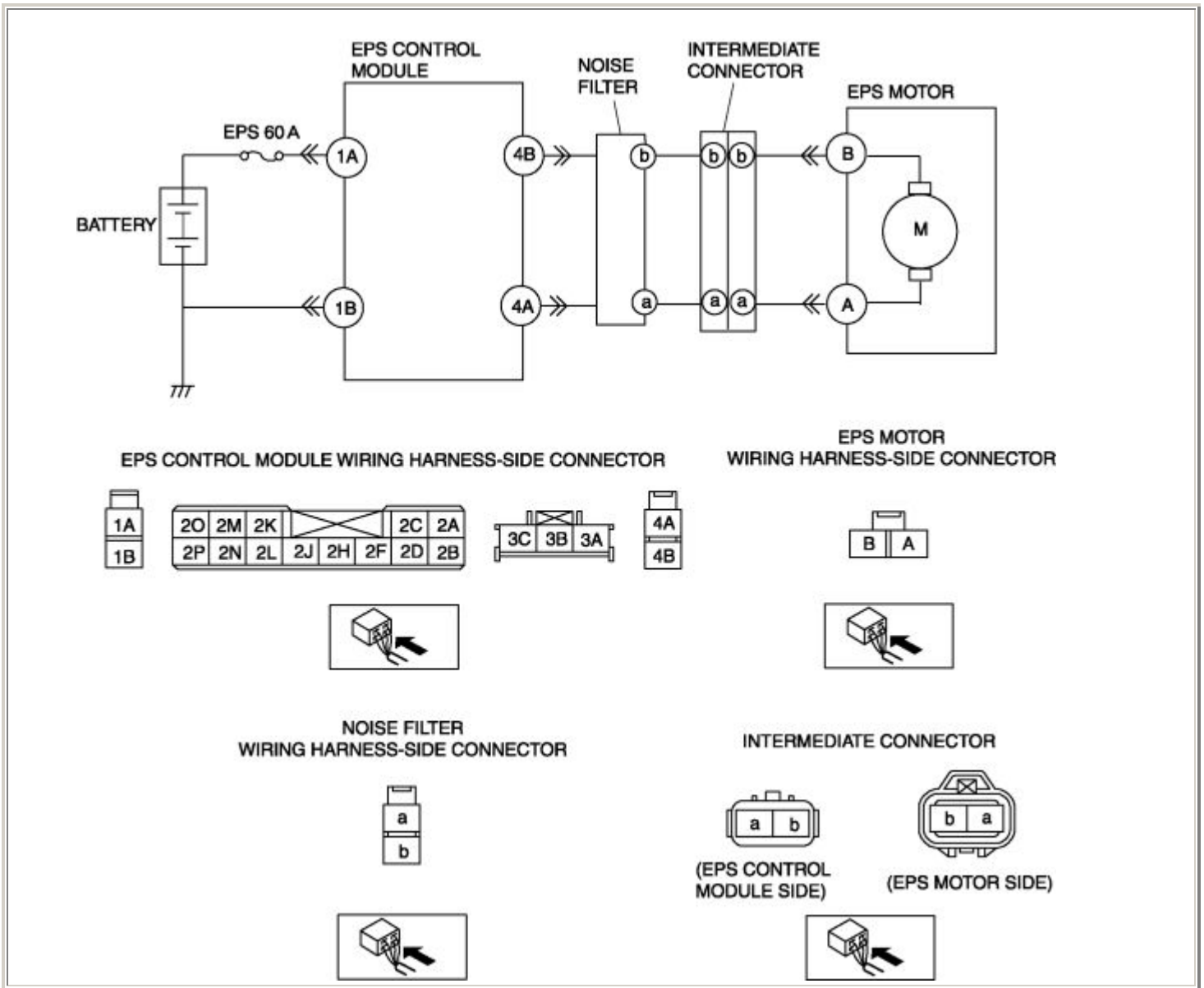

Diagnostic procedure

STEP	INSPECTION	ACTION	
1	INSPECT FUSE  Inspect EPS 60 A fuse. Is EPS 60 A fuse normal?	Yes	Go to the next step.
		No	Replace EPS 60 A fuse, then go to Step 10.
2		Yes	Go to the next step.

	<p>INSPECT WHETHER MALFUNCTION IS CAUSED BY POOR CONNECTION OF EPS CONTROL MODULE OR PIN DEFORMATION</p> <p>Turn the ignition switch off. Inspect connection of the EPS control module and wiring harness. Disconnect the EPS control module connector. Inspect whether malfunction is caused by bent or poorly connected EPS control module connector pin. Are connection and pin of connector and wiring harness normal?</p>	No	Repair or replace faulty connector harness, then go to Step 6.
3	<p>INSPECT EPS MOTOR POWER SUPPLY CIRCUIT FOR OPEN CIRCUIT</p> <p>Disconnect the battery positive terminal. Inspect for continuity between EPS control module terminal 1A and battery positive terminal. Is there continuity?</p>	Yes	Go to the next step.
		No	Repair or replace the wiring harness for open circuit between the EPS control module and battery, then go to Step 10.
4	<p>INSPECT EPS MOTOR POWER SUPPLY CIRCUIT FOR SHORT TO GROUND</p> <p>Inspect for continuity between EPS control module terminal 1A and ground. Is there continuity?</p>	Yes	Repair or replace the wiring harness for short to ground between the EPS control module and battery, then go to Step 10.
		No	Go to the next step.
5	<p>INSPECT EPS MOTOR CIRCUIT FOR OPEN CIRCUIT</p> <p>Disconnect the noise filter connector. Inspect for continuity between the EPS control module terminals and noise filter terminals.</p> <ul style="list-style-type: none"> <li>▪ EPS control module terminal 4A—noise filter terminal a.</li> <li>▪ EPS control module terminal 4B—noise filter terminal b.</li> </ul> <p>Is there continuity?</p>	Yes	Go to the next step.
		No	Replace the noise filter, then go to Step 10.
6		Yes	Go to the next step.

	<p><b>INSPECT EPS MOTOR CIRCUIT FOR OPEN CIRCUIT</b></p> <p>Disconnect the EPS motor connector. Inspect for continuity between the EPS motor terminals and noise filter terminals.</p> <ul style="list-style-type: none"> <li>▪ EPS motor terminal A—noise filter terminal a.</li> <li>▪ EPS motor terminal B—noise filter terminal b.</li> </ul> <p>Is there continuity?</p>	No	Repair or replace the wiring harness for open circuit between the EPS motor and noise filter, then go to Step 10.
7	<p><b>INSPECT EPS MOTOR CIRCUIT FOR SHORT TO POWER</b></p> <p>Measure the voltage between the EPS motor terminals and ground.</p> <ul style="list-style-type: none"> <li>▪ EPS motor terminal A—ground</li> <li>▪ EPS motor terminal B—ground</li> </ul> <p>Is there any B+?</p>	Yes	Repair or replace the wiring harness for short to power between the EPS motor and noise filter, then go to Step 10.
		No	Go to the next step.
8	<p><b>INSPECT EPS MOTOR CIRCUIT FOR SHORT TO GROUND</b></p> <p>Inspect for continuity between the EPS motor terminals and ground.</p> <ul style="list-style-type: none"> <li>▪ EPS motor terminal A—ground</li> <li>▪ EPS motor terminal B—ground</li> </ul> <p>Is there continuity?</p>	Yes	Repair or replace the wiring harness for short to ground between the EPS motor and noise filter, then go to Step 10.
		No	Go to the next step.
9	<p><b>INSPECT EPS MOTOR GROUND CIRCUIT FOR OPEN CIRCUIT</b></p> <p>Disconnect the battery negative terminal. Measure continuity between EPS control module terminal 1B and battery negative terminal.</p> <p>Is there continuity?</p>	Yes	Go to the next step.
		No	Repair or replace the wiring harness for open circuit between the EPS control module and battery, then go to the next step.
10	<p><b>VERIFY TROUBLESHOOTING COMPLETED</b></p> <p>Make sure to reconnect all disconnected connectors.</p> <p>Clear the DTC from the memory.</p>	Yes	<p>Replace the EPS control module and/or steering gear and linkage, then go to the next step.</p> <p>(See EPS CONTROL MODULE REMOVAL/INSTALLATION .)</p> <p>(See STEERING GEAR AND LINKAGE REMOVAL/INSTALLATION .)</p>

	(See Clearing DTCs Procedure .)  Turn the ignition switch off. Start the engine. Is the same DTC present?	No	Go to the next step.
11	VERIFY AFTER REPAIR PROCEDURE  Are any other DTCs present?	Yes	Go to the applicable DTC inspection. (See DTC Table .)
		No	DTC troubleshooting completed.

Notes:

## DTC B2141

<b>DTC</b>	<b>B2141</b>	<b>EPS system (neutral position setting not performed )</b>
<b>DETECTION CONDITION</b>	Failure to perform EPS control module neutral position setting detected.	
<b>POSSIBLE CAUSE</b>	EPS system neutral position setting not performed.	

### Diagnostic procedure

STEP	INSPECTION	ACTION
1	<b>PERFORM EPS SYSTEM NEUTRAL POSITION SETTING</b>  Perform the EPS system neutral position setting.  (See EPS SYSTEM NEUTRAL POSITION SETTING .)	After completing the EPS system neutral position setting, go to the next step.
2	<b>VERIFY CURRENT MALFUNCTION STATUS</b>  Clear the DTC from the memory.  (See Clearing DTCs Procedure .)  Turn the ignition switch off. Start the engine. Is the same DTC present?	Yes Replace the EPS control module, then go to the next step.  (See EPS CONTROL MODULE REMOVAL/INSTALLATION .)
		No Go to the next step.
3	<b>VERIFY AFTER REPAIR PROCEDURE</b>  Are any other DTCs present?	Yes Go to the applicable DTC inspection.  (See DTC Table .)
		No DTC troubleshooting completed.

## DTC B2278

DTC	B2278	Torque sensor
<b>DETECTION CONDITION</b>	Abnormal input signal detected from torque sensor.	
<b>POSSIBLE CAUSE</b>	Open or short circuit in wiring harness between EPS control module terminals and torque sensor terminals: <ul style="list-style-type: none"><li>▪ EPS control module terminal 3A—torque sensor terminal A</li><li>▪ EPS control module terminal 3B—torque sensor terminal B</li><li>▪ EPS control module terminal 3C—torque sensor terminal C</li></ul> EPS control module malfunction Torque sensor malfunction Poor connection of connectors	

Notes:

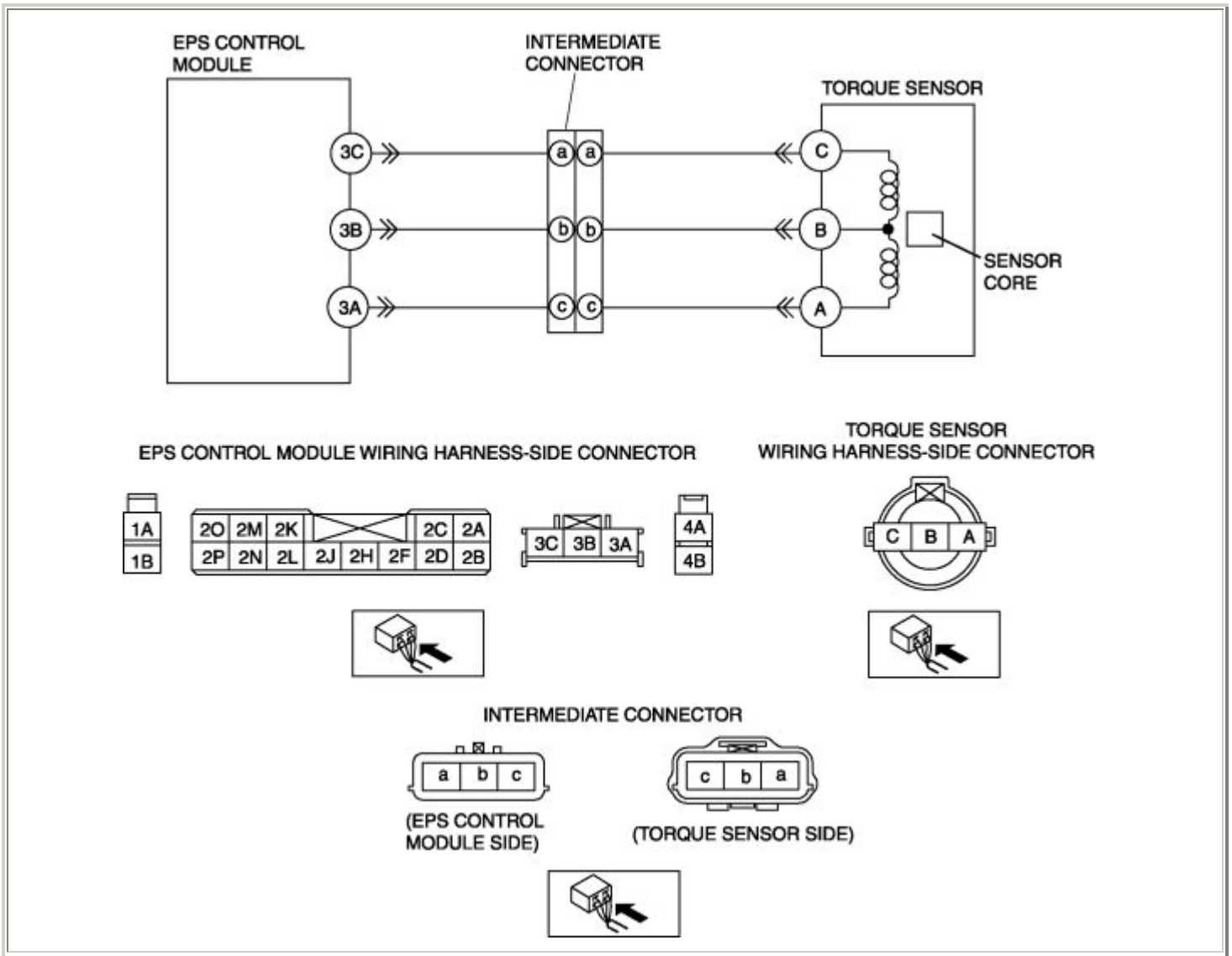

Diagnostic procedure

STEP	INSPECTION	ACTION
1		Yes Malfunction may be temporary. Go to step 7.

Notes:

	<p>INSPECT TORQUE SENSOR USING WDS OR EQUIVALENT</p> <p>Turn the ignition switch off. Connect the WDS or equivalent to the DLC-2. Turn the ignition switch to the ON position (engine OFF). Access TRQ_SENS PID. Verify that the data monitor value changes when the steering wheel is turned.</p> <p><b>Left: 0— -32 NM</b></p> <p><b>Right: 0—31.75 NM</b></p> <p>Do the torque sensor signal values change in the same way?</p>		
2	<p>INSPECT WHETHER MALFUNCTION IS CAUSED BY POOR CONNECTION OF EPS CONTROL MODULE OR PIN DEFORMATION</p> <p>Turn the ignition switch off. Inspect connection of the EPS control module and wiring harness. Disconnect the EPS control module connector. Inspect whether malfunction is caused by bent or poorly connected EPS control module connector pin. Are the connector connection, connector pins, and wiring harness normal?</p>	Yes	Go to the next step.
		No	Repair or replace the faulty connector wiring harness, then go to Step 7.
3	<p>INSPECT TORQUE SENSOR CIRCUIT FOR OPEN CIRCUIT</p> <p>Inspect for continuity between the EPS control module terminals and torque sensor terminals.</p> <ul style="list-style-type: none"> <li>▪ EPS control module terminal 3A—torque sensor terminal A</li> <li>▪ EPS control module terminal 3B—torque sensor terminal B</li> <li>▪ EPS control module terminal 3C—torque sensor terminal C</li> </ul> <p>Is there continuity?</p>	Yes	Go to the next step.
		No	Repair or replace the wiring harness for open circuit between the EPS control module and torque sensor, then go to Step 7.



4	<p><b>INSPECT TORQUE SENSOR CIRCUIT FOR SHORT TO POWER</b></p> <p>Measure the voltage between the torque sensor terminals and ground.</p> <ul style="list-style-type: none"> <li>▪ Torque sensor terminal A—ground</li> <li>▪ Torque sensor terminal B—ground</li> <li>▪ Torque sensor terminal C—ground</li> </ul> <p>Is there any B+?</p>	Yes	Repair or replace the wiring harness for short to power between the EPS control module and torque sensor, then go to Step 7.
		No	Go to the next step.
5	<p><b>INSPECT TORQUE SENSOR CIRCUIT FOR SHORT TO GROUND</b></p> <p>Inspect for continuity between the torque sensor terminals and ground.</p> <ul style="list-style-type: none"> <li>▪ Torque sensor terminal A—ground</li> <li>▪ Torque sensor terminal B—ground</li> <li>▪ Torque sensor terminal C—ground</li> </ul> <p>Is there continuity?</p>	Yes	Repair or replace the wiring harness for short to ground between the EPS control module and torque sensor, then go to the next step.
		No	Go to the next step.
6	<p><b>INSPECT TORQUE SENSOR</b></p> <p>Turn the ignition switch off. Disconnect the torque sensor connector. Measure the resistance between the torque sensor terminals.</p> <ul style="list-style-type: none"> <li>▪ Terminals A—B</li> <li>▪ Terminals B—C</li> </ul> <p><b>Resistance: 12—15 ohms</b></p> <p>Is the torque sensor normal?</p>	Yes	Go to the next step.
		No	Replace the steering gear and linkage, then go to Step 7.  (See STEERING GEAR AND LINKAGE REMOVAL/INSTALLATION .)
7	<p><b>VERIFY TROUBLESHOOTING COMPLETED</b></p> <p>Make sure to reconnect all disconnected connectors.</p>	Yes	Replace the EPS control module, then go to the next step.  (See EPS CONTROL MODULE REMOVAL/INSTALLATION .)

	<p>Clear the DTC from the memory.</p> <p>(See Clearing DTCs Procedure .)</p> <p>Turn the ignition switch off. Start the engine. Is the same DTC present?</p>	No	Go to the next step.
8	<p>VERIFY AFTER REPAIR PROCEDURE</p> <p>Are any other DTCs present?</p>	Yes	Go to the applicable DTC inspection. (See DTC Table .)
		No	DTC troubleshooting completed.

Notes:

## DTC C1099

DTC	C1099	EPS motor
<b>DETECTION CONDITION</b>	Abnormality detected in control current from EPS control module to EPS motor.	
<b>POSSIBLE CAUSE</b>	<p>Open or short to ground circuit in wiring harness between EPS control module terminal 1A and battery positive terminal</p> <p>Open or short circuit in wiring harness between the following EPS control module terminals and EPS motor terminals:</p> <ul style="list-style-type: none"><li>▪ EPS control module terminal 4A—EPS motor terminal A.</li><li>▪ EPS control module terminal 4B—EPS motor terminal B.</li></ul> <p>Open circuit in wiring harness between EPS control module terminal 1B and battery negative terminal</p> <p>EPS control module malfunction</p> <p>EPS motor malfunction</p> <p>EPS 60 A fuse malfunction</p> <p>Noise filter malfunction</p> <p>Poor connection of each connector</p>	

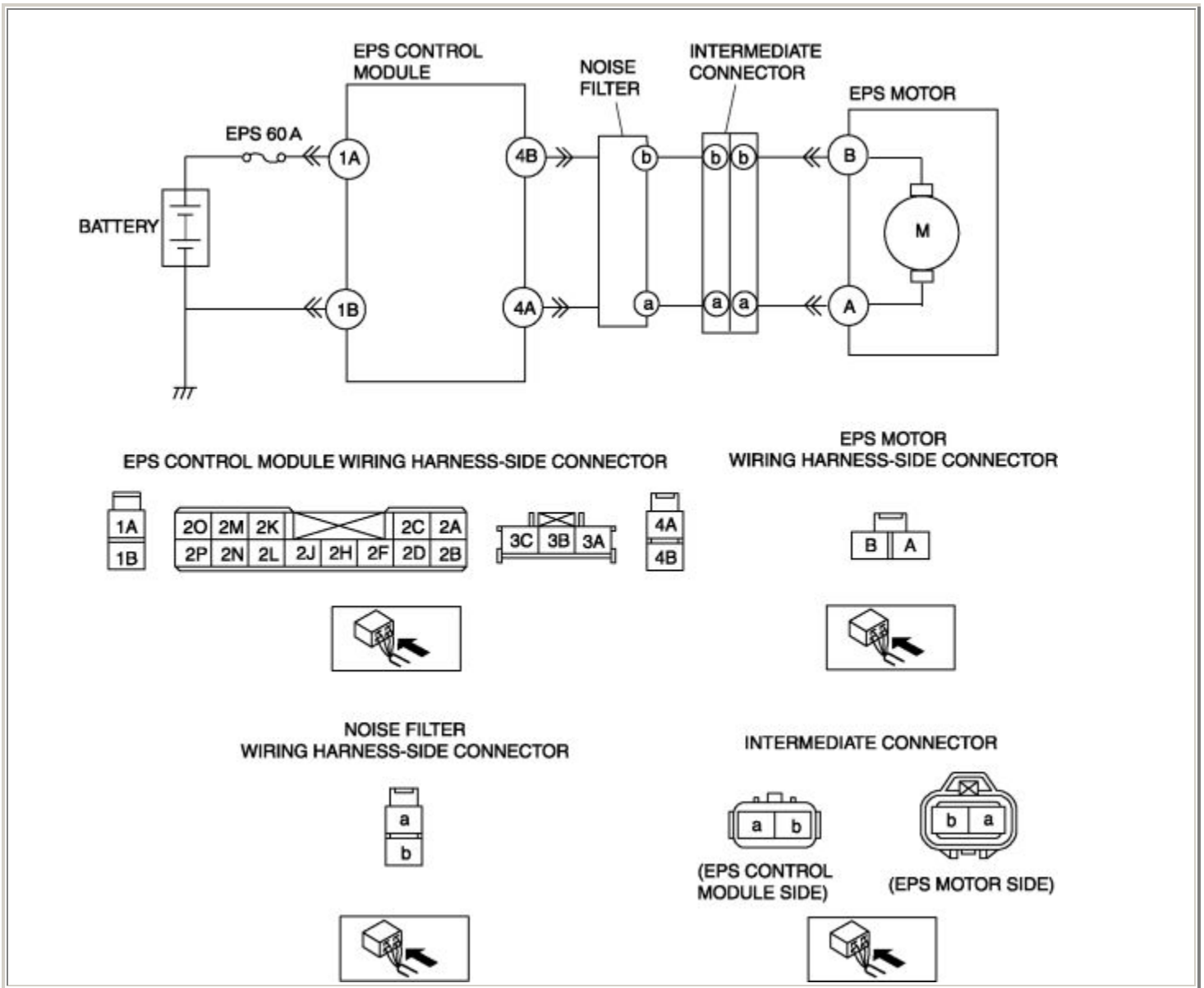

Diagnostic procedure

STEP	INSPECTION	ACTION	
1	INSPECT FUSE  Inspect EPS 60 A fuse. Is EPS 60 A fuse normal?	Yes	Go to the next step.
		No	Replace EPS 60 A fuse, then go to Step 10.
2		Yes	Go to the next step.

	<p>INSPECT WHETHER MALFUNCTION IS CAUSED BY POOR CONNECTION OF EPS CONTROL MODULE OR PIN DEFORMATION</p> <p>Turn the ignition switch off. Inspect connection of the EPS control module and wiring harness. Disconnect the EPS control module connector. Inspect whether malfunction is caused by bent or poorly connected EPS control module connector pin. Are the connector connection, connector pins, and wiring harness normal?</p>	No	Repair or replace the faulty connector wiring harness, then go to Step 6.
3	<p>INSPECT EPS MOTOR POWER SUPPLY CIRCUIT FOR OPEN CIRCUIT</p> <p>Disconnect the battery positive terminal. Inspect for continuity between EPS control module terminal 1A and battery positive terminal. Is there continuity?</p>	Yes	Go to the next step.
		No	Repair or replace the wiring harness for open circuit between the EPS control module and battery, then go to Step 10.
4	<p>INSPECT EPS MOTOR POWER SUPPLY CIRCUIT FOR SHORT TO GROUND</p> <p>Measure the voltage between EPS control module terminal 1A and ground. Is there continuity?</p>	Yes	Repair or replace the wiring harness for short to ground between the EPS control module and battery, then go to Step 10.
		No	Go to the next step.
5	<p>INSPECT EPS MOTOR CIRCUIT FOR OPEN CIRCUIT</p> <p>Disconnect the noise filter connector. Inspect for continuity between the EPS control module terminals and noise filter terminals.</p> <ul style="list-style-type: none"> <li>▪ EPS control module terminal 4A—noise filter terminal a.</li> <li>▪ EPS control module terminal 4B—noise filter terminal b.</li> </ul> <p>Is there continuity?</p>	Yes	Go to the next step.
		No	Replace the noise filter, then go to Step 10.
6		Yes	Go to next step.

	<p><b>INSPECT EPS MOTOR CIRCUIT FOR OPEN CIRCUIT</b></p> <p>Disconnect the EPS motor connector. Inspect for continuity between the EPS motor terminals and noise filter terminals.</p> <ul style="list-style-type: none"> <li>▪ EPS motor terminal A—noise filter terminal a.</li> <li>▪ EPS motor terminal B—noise filter terminal b.</li> </ul> <p>Is there continuity?</p>	No	Repair or replace the wiring harness for open circuit between the EPS motor and noise filter, then go to Step 10.
7	<p><b>INSPECT EPS MOTOR CIRCUIT FOR SHORT TO POWER</b></p> <p>Measure the voltage between the EPS motor terminals and ground.</p> <ul style="list-style-type: none"> <li>▪ EPS motor terminal A—ground</li> <li>▪ EPS motor terminal B—ground</li> </ul> <p>Is there any B+?</p>	Yes	Repair or replace the wiring harness for short to power between the EPS motor and noise filter, then go to Step 10.
		No	Go to the next step.
8	<p><b>INSPECT EPS MOTOR CIRCUIT FOR SHORT TO GROUND</b></p> <p>Inspect for continuity between the EPS motor terminals and ground.</p> <ul style="list-style-type: none"> <li>▪ EPS motor terminal A—ground</li> <li>▪ EPS motor terminal B—ground</li> </ul> <p>Is there continuity?</p>	Yes	Repair or replace the wiring harness for short to ground between the EPS motor and noise filter, then go to Step 10.
		No	Go to the next step.
9	<p><b>INSPECT EPS MOTOR GROUND CIRCUIT FOR OPEN CIRCUIT</b></p> <p>Disconnect the battery negative terminal. Measure continuity between EPS control module terminal 1B and battery negative terminal.</p> <p>Is there continuity?</p>	Yes	Go to the next step.
		No	Repair or replace the wiring harness for open circuit between the EPS control module and battery, then go to the next step.
10	<p><b>VERIFY TROUBLESHOOTING COMPLETED</b></p> <p>Make sure to reconnect all disconnected connectors.</p>	Yes	<p>Replace the EPS control module, then go to the next step.</p> <p>(See EPS CONTROL MODULE REMOVAL/INSTALLATION .)</p>

	<p>Clear the DTC from the memory.</p> <p>(See Clearing DTCs Procedure .)</p> <p>Turn the ignition switch off. Start the engine. Is the same DTC present?</p>	No	Go to the next step.
11	<p>VERIFY AFTER REPAIR PROCEDURE</p> <p>Are any other DTCs present?</p>	Yes	Go to the applicable DTC inspection. (See DTC Table .)
		No	DTC troubleshooting completed.

Notes:

# TECHNICAL DATA

## STEERING

### STEERING SYSTEM

Item			Specifications	
Steering wheel	Play	(mm {in})	0—30 {0—1.2}	
	Effort (reference value)	(N·m {kgf·cm, in·lbf})	5.0 {50, 44} or less	
Steering shaft	Length	(mm {in})	508.5 {20.02}	
Steering gear and linkage	Pinion shaft	Rotation torque	(N·m {kgf·cm, in·lbf})	1.2—2.0 {13—20, 11—17}
		[Pull scale reading]	(N {kgf, lbf})	11.2—20.0 {1.15—2.03, 2.52—4.48}
	Tie-rod end ball joint	Swinging torque	(N·m {kgf·cm, in·lbf})	0.6—2.0 {6—20, 5—17}
		[Pull scale reading]	(N {kgf, lbf})	5.9—19.6 {0.61—1.99, 1.33—4.40}
	Tie rod ball joint	Rotation torque	(N·m {kgf·cm, in·lbf})	0.68—2.45 {7.0—24.9, 6.1—21.6}
		[Pull scale reading]	(N {kgf, lbf})	6.8—24.5 {0.70—2.49, 1.53—5.50}

Notes: