



Features

- Temperature and supply voltage compensated flashing frequency
- Frequency doubling indicates lamp outage
- Two relay driver outputs with high current-carrying capacity and low saturation voltage
- Minimum lamp load for flasher operation: $\geq 1W$
- Very low susceptibility to EMI
- Protection according to ISO/TR7637/1 level 4
- Extremely low current consumption $< 10\mu A$ (with switches open)
- Reverse polarity protection
- Three control inputs: left, right and hazard warning

Description

The Atmel® integrated circuit U2044B is used in relay-controlled automotive flashers. With two output stages, each side of the vehicle is controlled separately. A left and a right direction indicator input with only a small control current makes switch contacts for small loads possible.

The separate hazard warning input simplifies the construction of the hazard switch. Lamp outage is indicated by frequency doubling during direction mode. Thanks to extreme low current consumption the U2044B can be directly connected to the battery.

Figure 1. Block Diagram

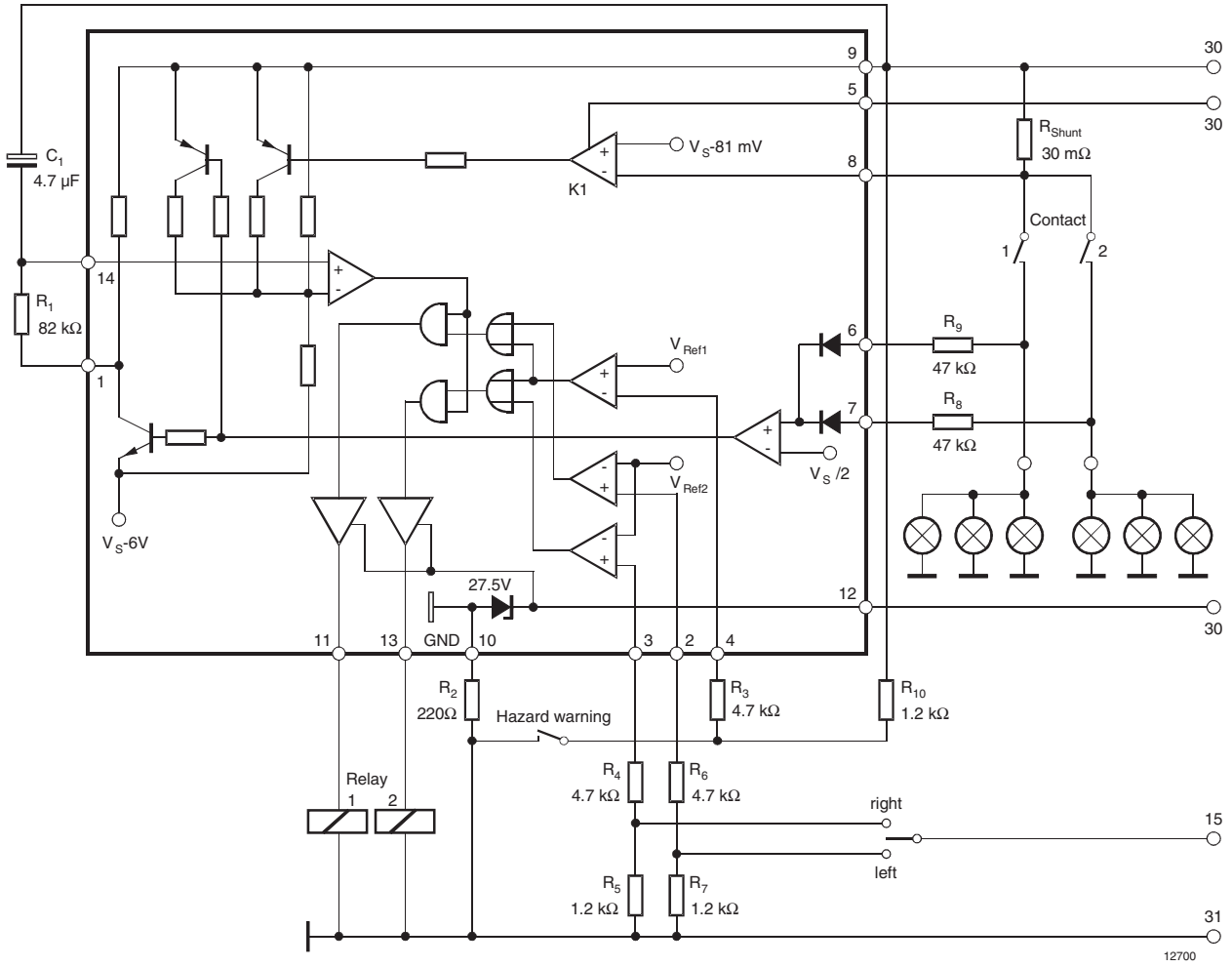

1. Pin Configuration

Figure 1-1. Pinning SO14

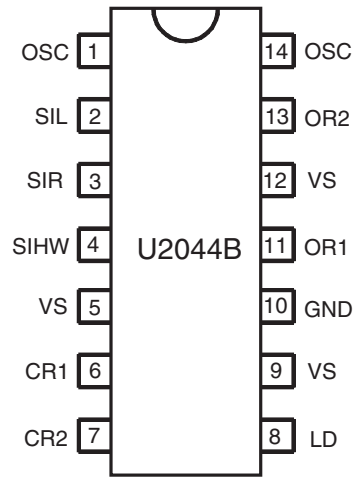

Table 1-1. Pin Description

Pin	Symbol	Function
1	OSC	Oscillator
2	SIL	Start input left
3	SIR	Start input right
4	SIHW	Start input hazard warning
5	VS	V _S
6	CR1	Control input relay 1
7	CR2	Control input relay 2
8	LD	Lamp failure detection
9	VS	V _S
10	GND	IC ground
11	OR1	Output relay 1
12	VS	V _S
13	OR2	Output relay 2
14	OSC	Oscillator

2. Functional Description

2.1 Oscillator (Pin 1 and 14)

Flashing frequency, f_1 , is determined by the R_1C_1 components as follows (see [Figure 1 on page 2](#)):

$$f_1 \approx \frac{1}{R_1 \times C_1 \times 1.5} \text{ Hz}$$

where $C_1 \leq 47\mu\text{F}$
 $R_1 = 6.8 \text{ k}\Omega$ to $180\text{k}\Omega$

In the case of a lamp outage, the oscillator frequency is switched to the lamp outage frequency f_2 with $f_2 \approx 2.2 \times f_1$.

Duty cycle in normal flashing mode: 50%
Duty cycle in lamp outage mode: 40% (bright phase)

2.2 Start Input Right and Left (Pin 2 and 3)

Flashing is disabled as long as the input comparator is tied to GND (pull-down resistor R_7 or R_5). The high-side flasher switch left or right changes the comparator status and enables the output stage at pin 11 or pin 13. R_6 and R_4 are protection resistors for the input stage.

With an open flasher switch the current consumption is only $I < 10 \mu\text{A}$. The IC is kept in stand-by mode until there is a voltage drop of $V \approx 6.9\text{V}$ at the pull-down resistor.

Direction mode can only be activated when the ignition switch is in the ON-position as shown in [Figure 1 on page 2](#).

2.3 Start Input Hazard Warning (Pin 4)

In contrast to the direction switches, the hazard input is a low-side type. The pull-up resistor R_{10} provides the off-state. R_3 is a protection resistor for the input stage. Hazard warning can be activated independent of the ignition switch position.

2.4 Supply Voltage Sense (Pin 5)

This pin supplies the lamp outage comparator at pin 8 and is externally connected to the battery (KI 30).

2.5 Control Input Relay 1 and 2 (Pin 6 and 7)

The feedback detects the bright phase and the dark phase and enables the oscillator.

2.6 Lamp Outage Detection (Pin 8)

The lamp current is monitored via an external shunt resistor, R_{Shunt} and an internal comparator, K1, with its reference voltage of typically 81mV ($V_S = 12\text{V}$). The outage of one lamp out of two lamps is detected according to the following calculation:

Nominal current of 1 lamp: $21\text{W}/(V_S = 12\text{V})$: $I_{\text{lamp}} = 1.75\text{A}$
Nominal current of 2 lamps: $2 \times 21\text{W}/(V_S = 12\text{V})$: $I_{\text{lamp}} = 3.5\text{A}$

We recommend setting the detection threshold in the middle of the current range: $I_{\text{outage}} \approx 2.7\text{A}$

Thus the shunt resistor is calculated as:

$$R_{\text{Shunt}} = V_T (K1) / I_{\text{outage}}$$
$$R_{\text{Shunt}} = 81\text{mV} / 2.7 \text{ A} = 30 \text{ m}\Omega$$

Comparator K1's reference voltage is matched to the characteristics of filament lamps (see section "Control Signal Threshold").

The combination of the shunt resistor and the resistance of the wire harness prevents pin 8 from a too high voltage in the case of shorted lamps.

2.7 Supply Voltage (Pin 9)

This pin supplies the oscillator, the comparators and the logic parts of the IC.

2.8 GND (Pin 10)

The integrated circuit is protected against transients according to ISO-TR 7637-3 level 3 via resistor R_2 to ground (-31). An integrated protection circuit together with external resistors R_2 , R_3 , R_4 , R_6 , R_8 and R_9 limits the current pulses in the IC. The IC is also protected against reversed battery.

2.9 Control Output Relay 1 and 2 (Pin 11 and 13)

The relay control outputs are high-side drivers with a low saturation voltage and capable of driving a typical automotive relay with a coil resistance of 60Ω .

2.10 Supply Voltage Power (Pin 12)

This pin supplies the relay drivers connected directly to the battery (KI 30). It is internally clamped by a 27-V Z-diode.

3. Absolute Maximum Ratings

Stresses beyond those listed under “Absolute Maximum Ratings” may cause permanent damage to the device. This is a stress rating only and functional operation of the device at these or any other conditions beyond those indicated in the operational sections of this specification is not implied. Exposure to absolute maximum rating conditions for extended periods may affect device reliability.

Reference point pin 1

Parameters	Symbol	Value	Unit
Supply voltage, 1 min, pins 5, 9 and 12	V_S	24	V
Junction temperature	T_j	150	°C
Ambient temperature range	T_{amb}	-40 to +100	°C
Storage temperature range	T_{stg}	-55 to +150	°C

4. Thermal Resistance

Parameters	Symbol	Value	Unit
Junction ambient, SO14	R_{thJA}	120	K/W

5. Electrical Characteristics

Typical values under normal operation in application circuit [Figure 1 on page 2](#), $V_S (+30) = 12V$.

Reference point ground (-31), $T_{amb} = 25^\circ C$, unless otherwise specified

Parameters	Test Conditions	Symbol	Min.	Typ.	Max.	Unit
Supply voltage range	Pins 5, 9, 12	V_S	8		18	V
Supply current, switches open	Pins 5, 9, 12	I_S			10	μA
Output current for relay driver	Pins 11, 13	I_O			300	mA
Saturation voltage	$R_L = 82\Omega$ $V_S = 8V$ $V_S = 12V$	V_O			1.0	V
					1.2	V
Relay output reverse current	Pin 11, 13	I_O			0.1	mA
Relay coil resistance		R_L	60			Ω
Start delay	First bright phase	t_{on}			10	ms
Control signal threshold	$V_S = 9V$ $V_S = 13.5V$ $V_S = 16V$	V_S		70.6		mV
				85.0		mV
				93.0		mV
Tolerance of control signal threshold	$V_S = 9V$ to $16V$, pin 8, $T_{amb} = -140^\circ C$ to $100^\circ C$		-6		+6	%
Temperature coefficient of control signal threshold	$V_S = 13.5V$, pin 8	T_K		10		$\mu V/K$
Clamping voltage	$T_{amb} = -40^\circ C$ to $100^\circ C$	V_{12}	25.0	27.5	30.0	V
Relay output overvoltage detection (relay disabled)	$T_{amb} = -40^\circ C$ to $100^\circ C$	V_{12}	18	20	22	V

6. Tolerances

Typical values under normal operation in application circuit [Figure 1 on page 2](#), $V_S (+30) = 12V$.
Reference point ground (-31), $T_{amb} = 25^\circ C$, unless otherwise specified

Parameters	Test Conditions	Symbol	Min.	Typ.	Max.	Unit
Frequency determining resistor		R_1	6.8		510	$k\Omega$
Frequency determining capacitor		C_1			47	μF
Frequency tolerance	Normal flashing, basic frequency f_1 not including the tolerance of the external components R_1 and C_1	Δf_1	-5		+5	%
Bright period	Basic frequency f_1	Δf_1	47		53	%
	Control frequency f_2	Δf_2	37		45	%
Frequency increase	Lamp failure	f_2	$2.15 \times f_1$		$2.3 \times f_1$	Hz
Lamp load		P_L	1			W

7. Ordering Information

Extended Type Number	Package	Remarks
U2044B-MFPY	SO14	Tubed, Pb-free
U2044B-MFPG3Y	SO14	Taped and reeled, Pb-free

8. Package Information

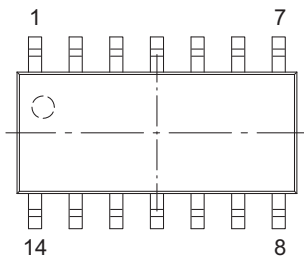
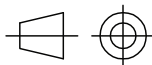
technical drawings according to DIN specifications

Dimensions in mm

Note¹): Dimensions "D" and "E1" do not include Moldflash or protrusion. (MAX. 0.15mm per side)

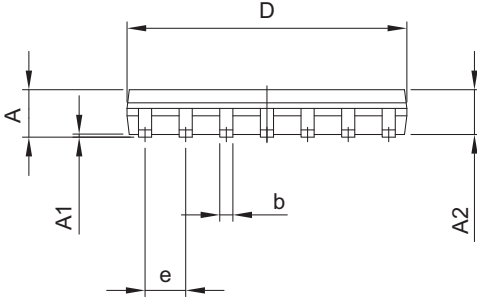
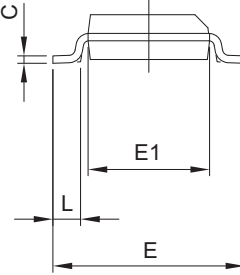
Bemerkung: ASE

COMMON DIMENSIONS (Unit of Measure = mm)			
Symbol	MIN	NOM	MAX
A	1.35	1.55	1.75
A1	0.10	0.18	0.25
A2	1.25	1.38	1.50
b	0.33	0.42	0.51
C	0.19	0.22	0.25
D ¹)	8.55	8.65	8.75
E ¹)	3.80	3.90	4.00
E	5.80	6.00	6.20
e		1.27 BSC	
L	0.40	0.84	1.27

04/13/12

Package Drawing Contact: packagedrawings@atmel.com	TITLE Package: SO14	GPC	DRAWING NO. 6.541-5053.01-4	REV. 1

9. Revision History

Please note that the following page numbers referred to in this section refer to the specific revision mentioned, not to this document.

Revision No.	History
4721D-AUTO-05/12	<ul style="list-style-type: none">• Section 8 “Package Information” on page 8 changed
4721C-AUTO-02/08	<ul style="list-style-type: none">• Put datasheet in the newest template• Pb-free logo on page 1 deleted• Figure title Figure 2-1 on page 3 renamed• Section 5 “Thermal Resistance” on page 6 changed• Section 8 “Ordering Information” on page 7 changed• Section 9 “Package Information” on page 7 changed
4721B-AUTO-09/05	<ul style="list-style-type: none">• Put datasheet in the newest template• Pb-free logo on page 1 added• New heading rows in Table “Absolute Maximum Rating” on page 6 added• Ordering Information on page 7 changed



Enabling Unlimited Possibilities™

Atmel Corporation

2325 Orchard Parkway
San Jose, CA 95131
USA

Tel: (+1) (408) 441-0311

Fax: (+1) (408) 487-2600

www.atmel.com

Atmel Asia Limited

Unit 01-5 & 16, 19F
BEA Tower, Millennium City 5
418 Kwun Tong Roa
Kwun Tong, Kowloon

HONG KONG

Tel: (+852) 2245-6100

Fax: (+852) 2722-1369

Atmel Munich GmbH

Business Campus
Parkring 4
D-85748 Garching b. Munich
GERMANY

Tel: (+49) 89-31970-0

Fax: (+49) 89-3194621

Atmel Japan G.K.

16F Shin-Osaki Kangyo Building
1-6-4 Osaki
Shinagawa-ku, Tokyo 141-0032
JAPAN

Tel: (+81) (3) 6417-0300

Fax: (+81) (3) 6417-0370

© 2012 Atmel Corporation. All rights reserved. / Rev.: 4721D-AUTO-05/12

Atmel®, Atmel logo and combinations thereof, Enabling Unlimited Possibilities®, and others are registered trademarks or trademarks of Atmel Corporation or its subsidiaries. Other terms and product names may be trademarks of others.

Disclaimer: The information in this document is provided in connection with Atmel products. No license, express or implied, by estoppel or otherwise, to any intellectual property right is granted by this document or in connection with the sale of Atmel products. EXCEPT AS SET FORTH IN THE ATMEL TERMS AND CONDITIONS OF SALES LOCATED ON THE ATMEL WEBSITE, ATMEL ASSUMES NO LIABILITY WHATSOEVER AND DISCLAIMS ANY EXPRESS, IMPLIED OR STATUTORY WARRANTY RELATING TO ITS PRODUCTS INCLUDING, BUT NOT LIMITED TO, THE IMPLIED WARRANTY OF MERCHANTABILITY, FITNESS FOR A PARTICULAR PURPOSE, OR NON-INFRINGEMENT. IN NO EVENT SHALL ATMEL BE LIABLE FOR ANY DIRECT, INDIRECT, CONSEQUENTIAL, PUNITIVE, SPECIAL OR INCIDENTAL DAMAGES (INCLUDING, WITHOUT LIMITATION, DAMAGES FOR LOSS AND PROFITS, BUSINESS INTERRUPTION, OR LOSS OF INFORMATION) ARISING OUT OF THE USE OR INABILITY TO USE THIS DOCUMENT, EVEN IF ATMEL HAS BEEN ADVISED OF THE POSSIBILITY OF SUCH DAMAGES. Atmel makes no representations or warranties with respect to the accuracy or completeness of the contents of this document and reserves the right to make changes to specifications and products descriptions at any time without notice. Atmel does not make any commitment to update the information contained herein. Unless specifically provided otherwise, Atmel products are not suitable for, and shall not be used in, automotive applications. Atmel products are not intended, authorized, or warranted for use as components in applications intended to support or sustain life.

Mouser Electronics

Authorized Distributor

Click to View Pricing, Inventory, Delivery & Lifecycle Information:

[Atmel:](#)

[U2044B-MFPG3Y](#) [U2044B-MFPY](#) [U2044B-MY](#)