

## DIY Mazda RX8 2005 Series 1 Automatic Sport Suspension 60K Maintenance (Fuel Line [Update 11/11/2017](#))

This 2005 Series 1 4-Port Automatic Grand Touring RX8 drove routinely between San Diego and Area 51 Nevada. Within 5000 miles a new engine was installed due to Nevada heat and original engine design. Synthetic 5-30W Mobil 1 Oil has been used consistently [Link](#). A MazdaSpeed Air Intake was installed by Mazda that removed the VDI and changed the Upper Intake Manifold. 12 years and 55K miles, the desire is to keep this exciting car. This exhaustive DIY Maintenance was performed with RX8Club references [Link](#). What starts out simple gets complex, all pods get knocked off course.

* Purchased (√ Installed or Used)	Links	Qty	Remarks	\$ Cost
<b>Tools</b>				<b>0</b>
√ Torque Socket Wrench (10-150 ft.-lb.)		1	Does not need to be fancy or long	20
√ Oil Drain Pan		1	One gallon oil total comes out	17
√ Oil Filter Wrench		1	Hard reach, used K&N w top nut	10
√ Funnel (FloTool Measu-Funnel)	<a href="#">Link</a>	1	Put in Oil and Transmission Fluid	4
√ Turkey Baster		1	Removes reservoir brake fluid	3
√ Jack Stands 2 ton		2 pair	All 4 Corners Up Solid	50
√ Transfer Pump Hand Operated		1	Worked good on differential	12
√ Rotor Set Screw Impact Screwdriver		1	Worked good, screwed off easy	19
√ Rear Brake Caliper Piston Reseat Socket Adapter		1	Rotates piston back in	10
√ Fuel Pressure Gauge		1	100 psi max	45
√ Vacuum Pressure Gauge		1	30 in hg max	25
√ BAFX Blue Tooth OBD II		1	Clear Check Engine Light	20
√ OBD II Diagnostic Bluetooth Torque Pro software	<a href="#">Link</a>	1	Not much learned, fun 2 watch	5
√ Fuel Pump Removal Tool	<a href="#">Link</a>	1	Required to force over black tabs	14
√ Brake Bleeder End Wrench 10mm and 8mm		1 each	Rear 10 mm Front 8 mm	10
√ Narrow Pivot Socket Extension		1	Spark Plug Tight Space	10
√ Fast Orange Hand Cleaner & Shop Towels (5 Pack)			Messy jobs	10
			<b>Tools Sub Total \$284</b>	<b>-0</b>
<b>Fluids</b>				
√ Brake Dot 3 Valvoline Brake Fluid \$7.99 1 Liter DOT3/4		2 Qrts	Sold everywhere	8
√ R Differential GL-5 MTL 75W90		2 Qrts	Only GL-5	17
√ Engine Oil Mobile 1 Synthetic 5-30w		5 Qrts	Also Amsoil XLF1G 5W30 <a href="#">Link</a>	7
√ Oil Filter K&N PN: HP1008: HP-1015		1	Hard reach, used K&N w top nut	15
√ Spark Plugs anti-seize grease		1	Sold everywhere	5
√ Brake Cleaner		1	Sold everywhere	5
√ Sea Foam Spray Clean & Lube		1	Debris removed fouls plugs	13
√ Chevron Techron Fuel Injector Cleaner		1	Caution debris removed fouls	10
√ Caliper Pin Lubricant and Rotor Antiseize Lubricant		4 each	Small packs also larger tubes	8
√ 3M Headlight Restoration Kit with Drill Attachment		1	1 hour each light works good	22
√ CRC QD or CRC MAF Sensor Cleaner		1	CRC MAF has cleaner propellant	8
√ Transmission Fluid M3 (0000-77-112E-01)	<a href="#">Link</a>	6-9 qts	Long discussion on attached page	48
√ R134A Air Conditioner Refill w gauge (versus R12A)		1	Gauge is fun, not needed	-0
Transmission Filter and Seal Kit	<a href="#">Link</a>	1	18 Bolt Pan Drop, messy	-0
			<b>Fluids Sub Total \$166</b>	<b>-0</b>
<b>Parts</b>				
√ Trans Fill / Trans Drain Washers Y601-17-361 18 mm		1 pair	No drain/fill plugs in 2005 RX8 AT	0
√ Oil Drain Washer 9956-41-800 ½" 14mmx1.5mm (0.55")	<a href="#">Link</a>	1	653306 OD=13/16";ID=9/16"	5
√ Diff Fill / Drain Washers Copper 18 mm		1 pair	Always use new crush washers	3
√ Air Filter (MazdaSpeed RX-8 GRMS-8M-K0 Installed)	<a href="#">Link</a>	No need to	replaced just wash	0
√ Slotted Gold Zinc (F/R Rotors/Pads RX8 Sports Suspension)	<a href="#">Link</a>	1	Slotted only, drilled adds no value	244
√ Spark Plugs NKG RE7C-L 3, NKG RE9B-T 2 (18mm)	<a href="#">LL LT</a>	4	Make sure 2 Leading 2 Trailing	80
√ Ignition Coils N3H1-18-100B-9U 18mm Kit (4 coils in kit)	<a href="#">Link</a>	1	New fail, check before install	40
√ Ignition Wires Kit 4	<a href="#">Link</a>	1	A good wire set goes forever	25
√ Permatex 22058 Dielectric Grease for Spark Plug Boots	<a href="#">Link</a>	1 Tube	Fuel Injector use verified email	4
√ Tires	<a href="#">Link</a>	4	Lowest price \$65, Highest \$200	400
√ Battery	<a href="#">Link</a>	1	Lowest price U install, bring core	65
√ 04-11 Rx8 Center Console Lid Latch (F151-55-28XA)	<a href="#">Link</a>	1	Replace broken plastic piece	20
√ Cabin Air Filter	<a href="#">Link</a>	2	Got 3 Stage house filter at Lowes	8
√ Fuel Filter 5/16" In Line Mr. Gasket #9745 40 microns	<a href="#">Link</a>	1	(Keep debris from injectors)	9
√ Fuel Pump Delphi FG1250 \$135	<a href="#">Link</a>	1	(using fuel filter to isolate)	135
√ Fuel Injectors 4: 2 Primary / 2 Secondary	<a href="#">LP LS</a>	6 total	2005 RX8 Automatic Trans	254
√ Gates 27334 Fuel Injection Hose 5/16" 225 psi 275° F 4'	<a href="#">Link</a>	1	To Replace Quick Connect Hoses	14
√ Fuel Injection Hose Clamps 5/16"	<a href="#">Link</a>	8	To Replace Quick Connect Hoses	15
√ Gasket Upper Intake Manifold N3H413112A	<a href="#">Link</a>	2	Long Lead 10+ days deliver	12
√ Gasket Throttle Body RX8 N3H113655A	<a href="#">Link</a>	1	Long Lead 10+ days deliver	19
√ Gasket Oil Filler N3H613112	<a href="#">Link</a>	1	Long Lead 10+ days deliver	5
√ Fuel Hose N3H1-13-49XB	<a href="#">Link</a>	1	Long Lead 10+ days deliver	47
			<b>Parts Sub Total \$1404</b>	<b>\$1854</b>
<b>Total</b>				

## DIY RX8 2005 Series 1 60K Maintenance Notes

**Warnings before Incantations:** Remove the negative battery terminal if working with fuel. Don't present sparks or ignitions around fuel (smoking). Be sure the engine is cold if working with fluids. Wear gloves to avoid skin cancer risks.

**Process Control:** Go slow. Take pictures. Store groups of nuts, bolts, or parts in separate plastic baggies marked with a Sharpie. Put a flattened cardboard box under the car to catch fluids. When hard to reach nuts, bolts, and tools slip out of your hand and fall through the engine they will make a resounding thud on the cardboard box. No thud, then you will have to go fishing with a magnet attached to 3/8" PVC or a stick. The strut frames and transmission top are likely catch spots.

**Tires:** Four new tires were installed [Link](#). Lug nuts are 21 mm (13/16") torqued 87 ft-lb, used pinch weld for jack stands.

**Battery:** A new battery was purchased for \$65 and installed at home [Link](#). Bring old battery core to save time and money.

**Spark Plugs:** Removed driver front wheel, replaced NKG Iridium plugs torqued to 18- ft/lbs, felt crush washers give.

**Engine & Differential Oils and Filter:** Replaced engine and differential oils. The oil plug was torqued 22 ft/lbs. The differential plug was torqued 29 ft/lbs. The K&N oil filter top nut is 1" or 25.4 mm. Smear oil on the rubber ring. Understand mineral vs. synthetic oil and 520W vs. 530W oil weight discussions, always used 530W Mobil 1 Synthetic Oil.

**Automatic Transmission Fluid & Filter:** There are no 2005 RX8 4-Speed Automatic Transmission fluid drain/fill plugs. Eighteen bolts are removed and the pan dropped. Transmission fluid selection and filter selection is complex. Mazda sells the required M3. Royal Purple ATF is not compatible and will destroy the syncros. Did not drop pan, removed fluid through the transmission dip stick with a hand pump. 3/8" I.D. PVC tube was inserted into the hand pump PVC. A funnel with measure marks, screen filter, and stop cock was used to accurately measure amount out and inspect for debris [Link](#). Got 10 quarts of M3 at Mazda Parts Department for \$80, removed 4 quarts, replaced and drove, removed 2 quarts, replaced. In 4 weeks 4 more quarts will be removed and replaced, a total of 10 quarts. The transmission is operating very smooth.

**Rotors and Pads:** The 'slotted only' rotor boxes were marked left-right. The new rotors were cleaned with brake cleaner. Antiseize was placed inside the rotor hubs. Lubricated the caliper pins and metal pad holders. A Rear Caliper Piston tool cube seated rear calipers. After research, drilled rotors provide no extra performance, not used in racing, just look good.

**Brake Fluid Replace and Bleed:** A bottle with a top 5/8" hole was used to hold brake bleed fluid. A turkey baster was used to partially drain the master cylinder reservoir to remove old fluid while leaving enough not to get air into the system. The bottle was filled 1/3. 3/8" I.D. PVC tube was looped above bleeder to bottle. An upside down bucket held the bottle. To finish bleeding, the engine was turned on. Replaced both 8 mm-1" front bleeder screws. Calipers/lines were banded to dislodge air bubbles. The master cylinder was bleed several times. Always kept the reservoir full with Dot 3 brake fluid.

**Headlights:** Used 3M Headlight Restore Kit to sand/polish the headlights crystal clear. The kit worked lights crystal clear.

**Spark Plug Coils & Wires:** New spark plug coils and spark plug wires were installed with dielectric grease on the wire boots. Put dielectric grease under the spark plug coils before mounting. WD40 removed nuts, 3M oil to replaced nuts.

**Throttle Body Cleaning:** Injected Sea Foam Spray. Placed tube 1/4" in front of throttle flap with engine on, hot soaked for 15 minutes, then performed aggressive driving. There was not as much smoke from the tailpipes as the videos showed. There were warnings loosened debris could foul the plugs/fuel injectors resulting in a trim-system-to-lean P0171 code.

**Injector Cleaning:** Put Chevron Techron Fuel Injector Cleaner in gas tank. There were warnings that loosened debris could foul fuel injectors resulting in trim-system-to-lean P0171 OBD II code. Later, the primary injectors were fully clogged.

**Console Cover Latch / Cabin Filter:** The center front console cover latch was bent, ordered new [Link](#). A new cabin air filter was installed. A kit of 2x 1 stage filters was offered for \$34. A higher quality 3 stage trimable house filter was bought at Lowes for \$5. Ripped out old material, cut new to size, and slipped the new filter material into the old plastic frames.

**Reset NVRAM & KAM:** After Sea Foam and Techron, got P0171. Performed NVRAM/KAM reset procedures. Removed negative battery terminal, pressed brake 30 sec, reconnected battery, ignition on and engine off, did 20 brakes presses. Oil pressure gauge may jump on 20th press. With engine cold, turned engine on, idled for 20 min to relearn idle trims.

**MAF Sensor:** Idle a tad bit rough after Sea Foam and Techron with small hesitations at higher RPMs. Those symptoms did not exist before using those cleaners. The MAF Sensor was cleaned. Part # L321 TN197400-2160 82202 did not appear very dirty. The MAF and electrical contacts were cleaned with CRC QD. A new MAF was \$39. Idle is still a bit rough with small higher RPM hesitations after Sera Foam and Techron. At idle the MAF is a ~0.750 lb/min, at 70mph 2100 rpm ~5 to 7 lb/min range. The MAF sensor passed. Mazda desired \$95 for a new MAF, marketplace was \$34.

**O2 Sensor:** An [O2 sensor](#) cycles between 0.1 to 0.9 volts. An O2 sensor must reach 0.1 to 0.8 Volts to be operational. The O2 sensor must be warmed to above the 600 deg F. The O2 sensor must cycle at least once per second, 3 cross counts on the scan tool PID. The O2 Sensor affects the fuel ratio at idle. Bank 1 Sensor 1 (B1S1) is the pre-catalytic converter sensor and has the most affect on the fuel ratio. Used OBD II with Torque Pro smart phone software to verify the sensor was operational. This RX8 has a non-continuous O2 B1S1 (pre catalytic) and O2 B1S2 (post catalytic) OBD III accessible tests. The ECU tests are not immediate. Both RX8 ECU non-continuous tests passed.

**Struts / Shocks:** Front and Rear struts were checked by pushing down at the four corners (bounce test) and a road test. On the driving test, front dip and cornering passed. However, it is recommended shocks and struts be replaced at this 60k maintenance. Having passed, decided to leave this issue alone and defer for the 75k Maintenance.

**Air Intake Filter:** The entire front body work must be removed to get to the MazdaSpeed filter. The filter is good for life but needs to have cleaner sprayed on and water blown through the filter inside to out. Left in place, sprayed water, dried.

**Fuel Pump:** The RX8 has no OBD II measurement for fuel pressure. Desired 50+ psi, replace at 40- psi. A gauge was mounted, measurements taken. Given the 12 year old age, drop off in fuel pressure over 60 minutes with engine off, slight rough idle and slight hesitations at higher RPMs, **Fuel Pump Delphi FG1250** was ordered. An engine compartment 5/16" 40 micron push-in canister fuel filter was added. The higher rpm hesitations disappeared with the new fuel pump, a slight rough idle remained, primary fuel injectors suspect. The fuel line quick connect came off several days later, reseated.

**Fuel Injectors:** Installed GB Remanufacturing **84212330** Primary (2) and **84212331** Secondary (2) into this 4-Port Automatic. The boots were greased. Permatex email said Permatex Dielectric Grease is good, oil or gas good. Found one red Primary Front Injector clogged, the Primary Rear Injector was a carbon mess. The blue Secondary Injectors appeared good. UIM Intake Gaskets (2), Oil Gasket (1), and Throttle Gasket (1) took 10 business days to deliver, order well ahead.

**UIM Remove and Replace:** There are three hard to reach bolts, three hard to reach electrical connectors, and one plastic hose fitting near the oil filler port that goes nowhere, remains open with no hose to connect. A 4 1/4" 10mm open ended wrench helps to remove and replace two upside down bolts under a bracket connecting the upper and lower extensions.

**Fuel Hoses:** This issue started with an important diagnostic measuring fuel pressure, no place to connect that gauge, and no available quick connects to insert that gauge [Link](#). The fuel line next to the brake booster was cut, the rubber cover peeled back to expose the nylon inner tubing and a T connector inserted fuel hose clamped with 2x 5/16" high pressure fuel injection hose. Possibly not the best method, but it worked, the important measurements were taken. Later, during UIM rebuild after new fuel injectors were mounted, the cut hose line to secondary fuel rail was replaced with Gates Barricade MPI 27335 225 PSI SAE 30R9 high-pressure [fuel-injection system hose](#) fastened with double clamped high-pressure [fuel injection hose clamps](#). **11/11/2017: The Double Clamps Method failed**, as stated in the RX8 Club, the fuel line needs .70mm I.D., Gates is .78mm I.D. On the second test drive the quick connect at the fuel pump came off. An OEM fuel Hose connecting to the secondary fuel rail was purchased, the Gates hose and double clamps removed. [Link](#)

**Air Conditioning:** Note where the AC pump and clutch are. The low pressure refill valve is marked with an "L" on top of the gray cap located above the window washer fluid. If the AC is working, use a small can with gauge of R134A fluid and pressure to 35 lbs. It is easy to overfill the AC. If overfill, the clutch with turn on then off rapidly with no cooling, release some pressure. Drop the pressure down slowly until the clutch engages and stays engage for a period of time. Eye safety, gloves, a rag, and a small flat end are needed to push in the low pressure valve to release pressure. The **ACPro** trigger is also effective. R134a in your eyes can blind you permanently. The gloves and/or rag keep hands from freezing. If way under pressure (<25 lbs) you may need to fill to get the AC pump clutch to engage.

**OBD II/Torque Pro/Smart Phone:** An array of dynamic graphic charts on one screen with red circles showing bad transitions helps. However, there is no Fuel Pressure sensor, no Vacuum Pressure sensor, and no fuel pressure or vacuum pressure OBD II ECU reports on this 2005 RX8. Those two measurements are required for nearly all engine problem diagnostics. There is no valve to connect a fuel pressure gauge, there is an adapter you can purchase for \$60 with a Mazda quick connect [Link](#), a make shift can be created by cutting the fuel line and inserting a T with clamps and 5/16" high pressure fuel injector hose, or the expensive Mazda SST Fuel Pressure Gauge can be purchased [Link](#).

**Isolating Problems:** Mazda RX8 Workshop and Service manuals can be found [Here](#), [Here](#), and [Here](#) for free. Measuring vacuum and fuel pressure helps resolve rough idle and hesitations at speed problems. Coils, wires and plugs can be readily replaced and do not cost much. Because only the primary fuel injectors are active at idle, secondary injectors kick in >3000 rpm, clogged primaries are the rough idle suspects. The fuel pump is a primary suspect for hesitations at high speed. Coils, spark plugs, spark plug wires, fuel injectors, and the fuel pump are suspects for long crank engine turn on. Hoses do get old, a vacuum pressure measurement isolates the fault, brake cleaner fluid spray on hose or smoke locates. Finally, SSV and VDI carbon build up stuck mechanisms can be easily checked by manually moving the control arms. Is it a Fuel Problem or a Vacuum Problem? Need Fuel Pressure and Vacuum gauges to isolate.

**VIN JM1FE17N750142050:** This 4-port standard horsepower engine produces **191** hp (142 kW) with a 4-speed automatic transmission, a sunroof and leather seats (Grand Touring model). Prior to this 60k Maintenance there has never been a Check Engine Light, the original engine was replaced at 5k miles due to Nevada heat and the original engine design. Questions or comments can be sent email or to the RX8Club forum [Link](#).

**Detailing:** With everything working, this RX8 went to the beauty parlor for a wash, rinse, and detail. Although towels were used to cover the fenders, some grease and goop found a home. The grease and goop were cleaned off quickly to protect the paint. At 75k miles, the struts/shocks will be reviewed, 4 mores quarts of transmission fluid R&R in three weeks.

**Happy +7000 RPM Revs**

## DIY Check Engine Fault Code P0171 and P2096

**No Fault Codes have ever been generated on this RX8 prior to this 60K Maintenance (2005-2017)**

**Intermittent Engine Fault P0171 & P2096:** Sea Foam and Chevron Techron Fuel Injector Cleaner were used with warnings that debris may foul spark plugs and/or fuel injectors. The Sea Foam required the throttle body be exposed after the MAF sensor to inject the spray. New ignition coils, wires, and plugs had been installed. One day later after aggressive driving, the engine started dying at idle rpm and we have a P0171 code, cleared with OBD II. One week later, on a long freeway drive, P0171 and P2096 codes occurred, too much air or too little fuel. OBD II freeze frame data showed STFT1 at 25%, LTFT1 at 0%. After the CEL came on, the RX8 continued to run with slight rough idle and slight high rpm hesitations. Wrote down data, cleared fault, and ran the engine cold at idle. No fault returned. Suspect an intermittent vacuum hose, fuel pump, air intake fault, or clogged fuel injectors. After the engine is warm and turned off it takes longer to crank engine at startup. Four vacuum line hose clamps were added. The O2 sensors passed their non-continuous ECU tests. The MAF sensor was cleaned, data normal. The SSV and VDI actuators are not stuck, manually move smoothly.

Trim System to Lean: P0171 & P2096 Freeze Frame Data				
Fuel Sys 1	CC	Check Code Fault		
STFT B1	25.0%	Short Term Fuel Trim Bank 1		
LTFT B1	0%	Long Term Fuel Trim Bank 1		
MAF	5.817 Lb/Min	Mass Air Flow Sensor		
CLR DIST	21 Miles	Distance traveled before fault		
Warm DTC CLR	1	Warmed up		
Command EVAP	0%	Purge valve closed		
TPS	29.8%	Throttle Position Sensor		
IAT	66 Deg F	Intake Air Temperature Sensor		
Spark ADV	17 Deg	Spark Advance		
Vehicle Speed	65 Mph	Speed		
ECT	183 Deg F	Engine Coolant Temperature		
Fuel Pressure (FP) and Vacuum Pressure (VP) Tests (Engine Off) (No OBD II Sensors, Connected Gauges)				
Before Fuel Injectors and Fuel Pump Replace			After Fuel Injectors and Fuel Pump Replace	
Engine Off Minutes	FP (PSI)	VP (In Hg)	FP (PSI)	VP (In Hg)
0	55	16	56	16
15	48	16	56	16
30	38	15.5	56	15.5
45	28	15	55	15
55	22	15	55	15
60	19	15	54	15

### Intermittent P0171 & P2096 Diagnostics

**Fuel Pressure Inspection:** Cut the fuel line near brake booster. An Innova 3640 Fuel Injection Pressure Tester Kit (\$43) [Link](#) with T connector and clamps was inserted by cutting back the rubber hose cover each side by 1" and inserting the inner nylon hose into 5/16" high pressure fuel line. The check connector was grounded. The ignition switch was turned on with the engine off to operate the fuel pump. Measured the fuel line pressure, expected 54.4 - 65.2 psi, measured 55 psi. Disconnected the jumper wire and stopped the fuel pump. Waited 5 min and measured the fuel hold pressure at 48 psi.

Turned the car on to start the fuel pump with the engine off, then turned the ignition off and watched for 15 minutes. Expecting a steady 55 psi, the pressure dropped down 8 psi. Started the engine, measured, stays solid at 55 psi. Revved the engine, the engine maintained a fairly constant fuel pressure, quick revs showed a decrease and quick bounce back. At idle there is fast dither around 55 psi apparently related to the slight rough idle. Vacuum pressure stayed constant.

With engine off the fuel pressure should remain constant for an hour. If it drops fast, then the switched check valve in the fuel pump maybe faulty. The fuel pressure does drop slowly to 19 psi at 60 minutes. A slow leak of fuel pressure indicates the fuel injectors o-rings are leaking resulting in fuel to rich. There is rattling on the SSV Valve Control Arm hitting the end stop with rough idle. The SSV control arm rattles due to the slight rough idle. On first glance the fuel pump is good, but the drop off to 38 psi in 30 minutes remains a concern with the pump internal switched check valve. A fuel pump was ordered.

**Vacuum Pressure Inspection:** Used a vacuum pressure gauge inserted at the brake booster line. At idle and 2000 rpm pressure holds steady at 16 in hg (moving a bit) and stays steady at 16 in hg with engine off for over an hour.

**Fuel Injectors:** The MAF and vacuum pressure tests passed. Fuel pressure has a concern. Symptoms: Slight rough idle, slight hesitations at higher RPMs and the fuel pressure dither at idle with constant good vacuum. The SSV Valve Control Arm rattles (slight rough idle) as the fuel pressure dithers. Removed the test gauges, replaced connectors, tightened, and checked for leaks. A BAFX Blue Tooth OBD II with [Torque Pro](#) captured live data downloaded to a PC and viewed in Excel. The P0171 CEL, rough idle, and hesitation at high RPMs occurred after using Sea Foam and Techron Injector Cleaner. For slight rough idle, dirty primary fuel injectors are suspect. For high rpm hesitations the fuel pump is suspect.

## DIY Fuel Pump Remove and Replace (R&R) Check List

**R&R:** The **fuel pump** and **removal tool** (SST) arrived before the fuel injectors. Recommend a removal tool with thinner slotted arms than purchased. Tight work area for the purchased tool, the two black tabs takes lots of force to overcome. The decision to replace the fuel pump is due to fuel pump 12 year age and fuel pressure falloff rate 55 psi to 38 psi in 30 minutes with the engine off. That pressure fall off could be leaking fuel injectors.

**Cautions:** Securely attach the removal tool so that there is no gap between the removal tool tabs and the side of the cap, the fuel pump cap can be damaged if there is play. If the fuel pump unit is lifted too much the fuel suction pipe might be damaged, Make sure to lift the pump only a small amount when removing internal quick connects. Let fuel drain before removal old pump. The Rotation Angle is 50-140° (Total removal angle is 410-500°). The Cap Torque is 59-99 ft-lbf. Perform a fuel leak inspection by driving car back and forth 4-5 times.

**Black Locking Tabs:** There are two black tabs securing the ring, they don't move much, prying won't work, turn the ring with force. The top fuel connector has a center blue tab that needs to be pulled back to release. Electrical and fuel lines inside the pump go through the pump to reconnect. The inner fuel line needs the blue ring removed only. The o-ring appeared in good condition, did not replace. When placing the cover back on the new fuel pump, those same two black locking tabs required strong turning force to overcome, torqued to 89 ft-lbf. Checked for fuel leaks, none found. Reused the top fuel line quick connect, made sure connect is solid.

**Partial Success, slight hesitations at higher RPMs are gone.** Still slightly rough idle, even after cold idle fuel trims NVRAM and KAM resets. Fuel pump replace took about 2 hours. Suspect primary fuel injectors are clogged/dirty causing slight rough idle. Secondary injectors are active >~3000 rpm and do not affect idle. Added a fuel filter canister where the fuel pressure gauge was connected.

**Quick Connect Fail:** On a test drive, after fuel injector installation, the top fuel line quick connect line came off, leaked fuel all over. The desire is to cut off the quick connect, peeled back the outer cover exposing the nylon line inside, push into 5/16" high pressure fuel injection hose and clamp with high pressure fuel injection hose clamps. Mazda says the clamps will crush the inner nylon fuel hose. Another path is to replace the Main Fuel Pipe # F151-45-110A that runs the full length of the car from the pump to the rail and is about \$95 [Link](#). Due to failures, Mazda put a new style quick connect on that part [Link](#). Another alternative is to replace the last 11"-14" of flexible nylon fuel hose with high pressure fuel hose and high pressure fuel hose clamps. Instead, reseated the quick connect for now.

### Steps:

1. Remove the rear seat.
2. Remove the fuel pump service cover.
3. Make sure the fuel tank is 1/4 full or less.
4. Turn the engine on, pull the full pump fuse (20 amp yellow fuse third away from car center), then let the engine stop.
5. Turn the ignition off and remove the negative battery cable.
6. Put the full pump fuse back in.
7. Remove the fuel tank gas cap. (Ground yourself by touching car metal at each step)
8. Remove in the order indicated in the following page table. (Do not let connects and lines fall into the gas tank)
9. Install in the reverse order of removal. (Place rags underneath connectors when removing)

## DIY Fuel Pump Remove and Replace (R&R) Check List

1	Connector	<p style="text-align: right;">N-m {kgf-m, ft-lbf}</p> <p style="text-align: right;">CHU0114W028</p>	<p style="text-align: right;">BHJ0114W044</p>
2	Fuel pump cap	<p style="text-align: right;">N-m {kgf-m, ft-lbf}</p> <p style="text-align: right;">CHU0114W009</p>	<p style="text-align: right;">CHU0114W040</p>
3	Fuel pump unit	<p style="text-align: right;">N-m {kgf-m, ft-lbf}</p> <p style="text-align: right;">CHU0913W105</p>	<p style="text-align: right;">CHU0114W040</p>
4	Fuel suction pipe	<p style="text-align: right;">N-m {kgf-m, ft-lbf}</p> <p style="text-align: right;">CHU0913W105</p>	<p>Align the fuel pump unit alignment marks and the retainer notch as shown in the figure. If the retainer and cap cannot be tightened by hand, remove the cap, verify that there is no damage or misalignment on the retainer and cap, and then tighten again.</p>

## DIY 2005 RX8 4-Port Automatic Fuel Injectors Remove & Replace

**Clogged Fuel Injector Symptoms:** Engine stutter, hesitation, stumbling, misfire, performance loss, rough idle, stall, failed emission tests, increased fuel use, start issues, surge and buck. Fuel injectors clog when short period multiple ignitions and shut offs occur. Six fuel injectors were purchased, only 4 were needed for this 4-Port. Two ports are primary two are secondary. The primary are always on, the secondary kick in at >~3000 rpm. The figure shows both 4-port automatic and 6-Port manual systems. Found No flow rate specs for 84212330 (Red) and 84212331 (Blue). [RX8Club provides](#) the Primary Injectors are Red at 290cc and 4-Port Engine Secondary Injectors Blue at 480cc (4-port = 4 injectors = 1540cc total). The secondary is on the top outside rail, primary on the bottom inside rail. The internal fuel pump filter satisfies the GBR warranty. A 40 micron canister fuel filter was added in the engine compartment.

A reference for removing the Upper Intake Manifold is [2009 - 2011 RX8 UIM Removal](#). The UIM has two parts, Extension Upper (UIMU) for Air/Exhaust and Extension Lower (UIML) for Oil. The Lower Intake Manifold (LIM) is not removed.

**2005 RX8 Automatic** has 2 Primary in housing **N3R113250** and 2 Secondary in LIM **N3R213251**

**GB Remanufacturing 84212330:** Primary (4) GBR Ordered \$ 30.51 (\$254.22 6 injectors + Core) (2 Extra)

**GB Remanufacturing 84212331:** Secondary (2) GBR Ordered \$ 30.51 (Automatic Transmission)

**Mind Set:** Not a light hearted project, this will take a day. Go slow, have patience, be careful, step back. Record steps. Put each set of bolts and nuts in separately marked plastic bags. Make note of where hoses connect. Take many photos.

**Preparation:** Engine on, pulled fuel pump fuse to release fuel pressure, engine off replaced that fuse. Removed the negative battery cable, strut bar, MAF connector, air intake hoses, MazdaSpeed air intake, throttle body connector and hose, throttle body, UIMU to transmission dip stick bracket bolt (1), Washer Fluid Reservoir bolts (2) to get to the back UIMU bolt, and UIMU bolts (3). You cannot just "lift & remove" the UIM. Three difficult bolts, two are upside down in a tight space, one required releasing the window wash reservoir, and three difficult electrical connectors are annotated herein. The washer reservoir was moved over without disconnecting.

**UIMU Removal:** Started lifting Upper Intake Manifold (UIM). Found it has two parts, UIMU (Air) and UIML (Oil), See RX8 Engine Manual graphics on the last page. Fuel return quick connects had to be removed. The UIMU is connected to the UIML in two places. Pictures are shown on the following page. On the driver side, there are 2 bolts under the fuel line holder bracket. In the middle there is a Purge Solenoid Valve with two vacuum lines going up to UIMU and one atmosphere line going down not connected. Behind the bracket the two bolts attach the UIMU to the UIML. Getting two upside down 10 mm bolts out to separate the UIM proved difficult. The easiest way to get to these bolts is to pop the fuel line out of the two holders and bend the bracket up (straightening it). A short open end was used to break bolts free, fingers to unscrew. One small vacuum hose popped off the UIMU in back on the driver side, 2 hours later the UIMU is removed. If you can reach/remove the three difficult to reach electrical connectors, no need to remove those 2 bolts.

**UIML Removal:** Three electrical connectors and three small vacuum hoses on the back of the UIML are shown on the following page. The connectors, blue, white, and black top to bottom, were disconnected by pushing in the side plastic clips and wiggling. The UIML cleared the work area without disconnecting the vacuum hoses. Noted build up of grease in the oil flange, removed. Grease was removed from the matching housing port. The Secondary fuel rail is now visible.

**VDI Valve:** Removed the VDI valve mount bracket 10 mm bolt, swung the VDI up without removing clip. Removed two fuel line quick connects red (source) and blue (to primary rail). Removed two secondary fuel line rail bolts. The secondary fuel rail was removed.

**Secondary Rail Removal:** The RX8Club provides [DIY: Injector Replacement](#) with a 6-Port photo set (not this 4-Port). Wiggled the fuel rail out. Pushed a small screw driver under the wire harness plastic tabs, careful not to break, and pulled the wire harnesses off of the injectors. The Secondary Front wire is Green/Red. The Secondary Rear wire is Blue/Black. All White/Blue wires go to ground.

**Primary Rail Removal:** Removed two bolts below the secondary rail that holds the primary injector plate in place. Wiggled the fuel rail out. Flipped the plate over and removed the primary injectors from rail. Pushed a small screw driver under the wire harness plastic tabs, careful not to break, and pulled the wire harnesses off of the injectors. The Primary Front wire is Light Green/Red. The Primary Rear wire is Light Green/Black. All White/Blue wires go to ground. Note: Mazda uses "L" to indicate "Blue" in the wiring diagrams.

**Injector Install:** Inspected injector ports, found one rubber boot end fallen off, embedded and stuck, removed. Cleaned connectors with contact spray. Prepped injector seals with a thin coat of Permatex dielectric grease (email verified) being very careful not to get grease on the tips. Installed harnesses on injectors before placing into rails. Primary injector cups are deep, be sure to push the primary injectors in all the way down. Secondary tops need a push. Rails bolted back in. Made sure rail to rail fuel quick connects were tight.

**Fuel Lines:** Found note not to reuse high pressure quick connect lines due to fuel leaks, recommends new lines, true or false? The rail to rail fuel quick connect line was reused, removed 1 side only. Replaced rail fuel line with 2 feet of Gates 27335 4210BF 5/16" MPI high pressure fuel injection line (225 working psi 275° F) using four 5/16" fuel injection clamps. Double clamped the main fuel line at the secondary rail, and then single clamped other end to added canister fuel filter. Double clamped the canister fuel filter at the fuel source. On 2nd test drive the quick connect at the fuel pump came off. Reseated the quick connect and the connector has held.

**UIMU & UIML Rebuild:** Installed four O-ring gasket seals that took 10+ days to delivery, longest lead items of all, 2 UIMU Intake, 1 UIMU Oil Intake, and 1 Throttle gasket. Cleaned out the gaskets seats and oiled the gaskets. Removed white grease found in UIML oil port. The VDI valve was bolted on. The UIM oil filler driver side 2 nuts were inserted. With cleaned electrical connects and UIML in place, the three blue, white, and black UIML electrical connectors were inserted. With the UIMU placed, the passenger side 3 bolts and upside down two bolts on the driver side were bolted in without the bracket. All remaining fuel and vacuum hoses were connected. The Throttle Body gasket was inserted, the body bolted on, hose and electrical connected. The Air intake was mounted. The MAF electrical was connected. Fuel lines and vacuum were fastened to their holders. After checking all bolts and connects, the ignition was turned on with the engine off. A check for fuel leaks was made. The engine was then turned on and another check for leaks was made. We are now in a 20 minute NVRAM KAM idle trim reset calibration. Slight rough idle is gone. SSV Valve Control Arm rattling is gone.

**Nine hours have elapsed since project start to this point. Numerous breaks were taken, a go slow policy.**

**Test Drive:** Turned on OBD II with Torque Pro. The low speed uphill test is good. The high speed road test is very good. Loves hitting 7000+ RPM, this RX8 engine is running as smooth as silk. At 12 years old, this RX8 is now a very powerful young puppy again. This car has a lot of spirit, very fun to drive. Up until this 60K Maintenance, there has never been any problems since engine replace at 5k.

**Update 11/01/2017: The added High Pressure Fuel Injection filter blew out:** A garden hose has about 50 psi of water pressure, about the same as the RX8 fuel pump pressure. Removed the added in blown fuel filter and replaced with an in-line barb connector between the two sides of the Gates high pressure fuel injection fuel hose.

**Update 11/11/2017: Gates Hose with Double Clamp Method Failed:** the RX8 Club states the fuel line needs 7mm I.D., the Gates fuel hose is 7.94mm I.D. The Gates hose double clamps failed after six months, the clamps and hose were removed, an OEM Fuel Hose N3H1-13-49XB connecting to the secondary fuel rail was purchased and inserted. See figure below: [Link](#). (I.D. = Inner Diameter)

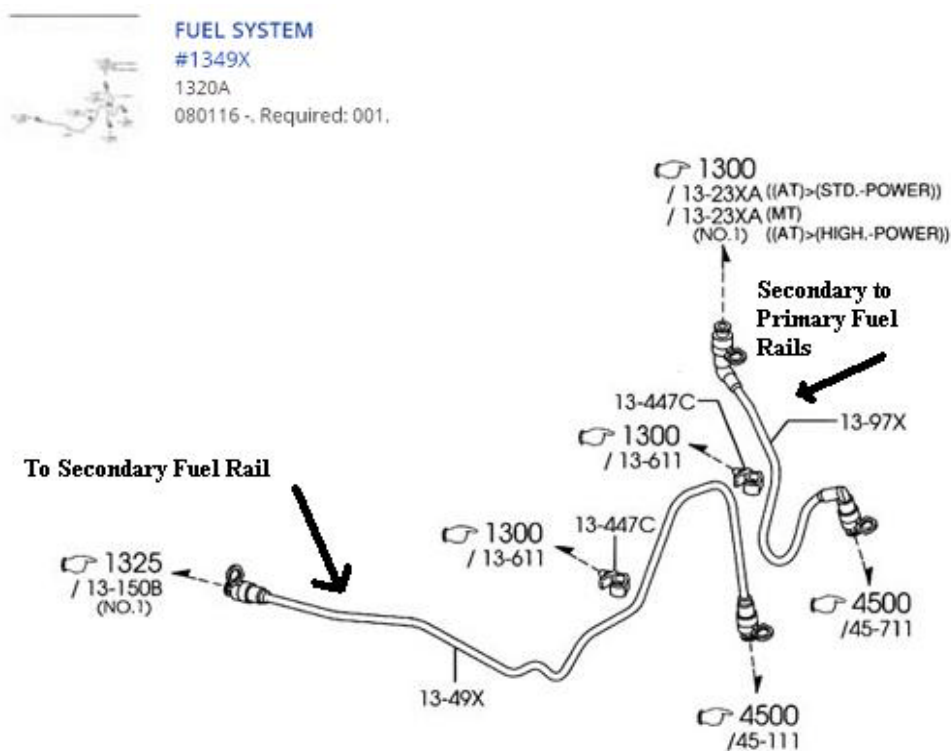

## DIY 2005 RX8 Automatic Fuel Injector R&R

Remove entire upper intake manifold. Remove the bolt holding the VDI actuator in place and swing it out of the way. Remove the hoses on the fuel rails. Remove the two bolts holding the fuel rail in place. Wiggle the fuel rail out and pull the injectors out of the rail and Lower Intake Manifold (LIM). Write down where wires went or mark the wire harness. Remove primary injectors from the second fuel rail.

1. Disconnect the negative battery cable
2. Remove Air Intake and Throttle Body (7)
3. Remove extension manifold (upper) (8)
4. Remove extension manifold (lower) (Not 2005 AT)
5. Remove the VDI actuator bracket installation bolt
6. Position the VDI actuator out of the way
7. Disconnect the fuel injector connector
8. Quick release connector
9. Fuel rail distributor (housing side)
8. Fuel rail distributor (intake manifold side)
10. Fuel injectors

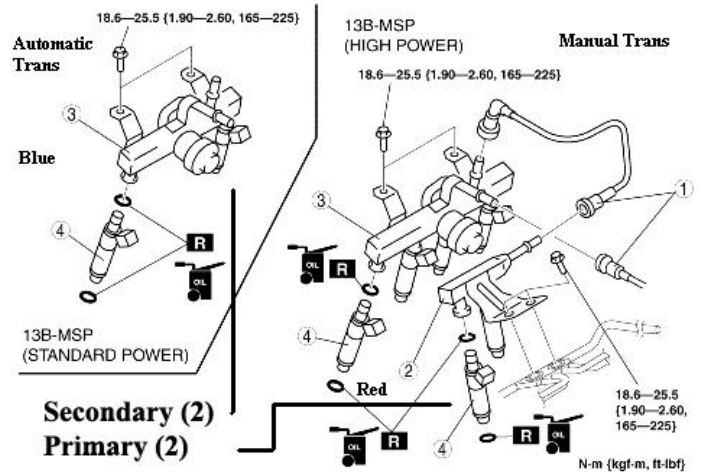
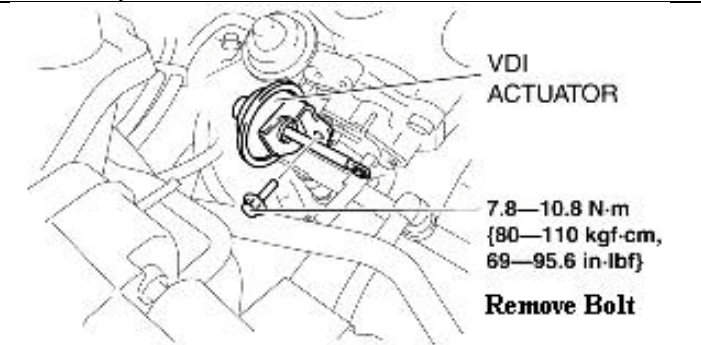

### Condition of Removed Fuel Injectors

Secondary Fuel Injectors (Top Blue)	Very Clean	Very Clean
Primary Fuel Injectors (Bottom Red)	Clogged	Carbon Dirt

The primary fuel injectors are on from idle through high revs. The secondary injectors come on at >~3000 rpm, don't affect idle.

Front Primary Injector is completely clogged with white oil-grease. Rear Primary Injector 4-Port Engine holes filled with carbon grime.

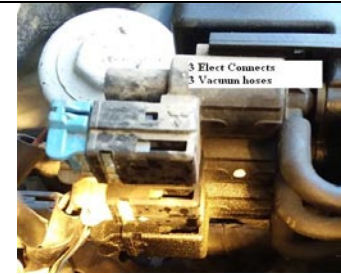
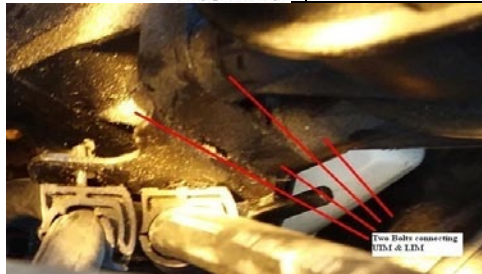

### RX-8 Basic Maintenance Information

Engine Oil	(3,000 miles)	Oil Filter	(3,000 miles)
Cabin Air Filter	(30-60,000 miles)	Inspect Drive belt	(24,000 miles)
Transmission Oil	(30,000 miles)	Differential Oil	(30,000 miles)
Spark Plugs	(30,000 miles)	Ignition Coils	(30,000 miles)
Plug Wires	(30-60,000 miles)	Brake Fluid	(45-60,000 miles)
Fuel Filter:	(60-100,000 miles)	Engine Coolant	(60,000 miles)

## DIY RX8 2005 Mazda M3 D3 Approved 4 Speed Automatic Transmission Fluid Maintenance

2005 MAZDA RX-8 1.3L Engine Code [N] ATF AF3	Link	Viscosity	6 Quarts	MD Compatibility
Valvoline Max-Life DEX/MERC Synthetic Transmission Fluid VV324	<a href="#">Link</a>	169	\$56.10	Mercon/D3
Pentosin ATF 1 (5 Liters) 5.2 Qts 20% off Code no good	<a href="#">Link</a>	171	\$75.99	M3/D6
AMSOIL OE Multi-Vehicle Synthetic Automatic Transmission Fluid	<a href="#">Link</a>	180	\$59.10	M3/D3
2005 RX8 Mazda Automatic Transmission M3 Fluid (0000-77-112E-01)	<a href="#">Link</a>	179	\$48	M3 (MIII)
<b>DIY FLUSH PARTS (Not Used, Removed Fluid Through Dip Stick and Replaced)</b>				
BANJO BOLT 18MM X 1.50 - \$5.50, MALE JIC TO 18MM X 1.50 - \$8.00, 18MM COPPER WASHER - \$0.60			<a href="#">Link</a> - <a href="#">Link</a> - <a href="#">Link</a>	
Oil Extractor Pump (Free Shipping)	<a href="#">Link</a>		\$16.98	
Auto Trans Filter Kit ATP 04-05 Mazda RX-8 1.3L-R2 (Filter and Gasket)	<a href="#">Link</a>		\$14.99	

Total Capacity 8.7 L 9.2 US qt. 2004-2005 4 speed automatic RX-8's use regular Dexron III ATF. Mazda Spec says ATF M-III or equivalent Dextron(R) III. Mazda Part # 0000-77-112E-01 says M3 (M-III). See picture below. Drop the transmission oil pan to drain the fluid, needs a new gasket to reinstall, refill thru dipstick [RX8Club Reference](#).

ATF M-III had a Viscosity Index (ASTM D-2270) of 179 [Link](#). Mazda Part # 0000-77-112E-01 has a high viscosity index. Lower viscosity = slight mpg up. Max-life ATF lower viscosity causes a down shifting dilemma. Dexron III ATF has a Viscosity index of 190. Dexron VI ATF has a lower viscosity index < 165 (to increase mpg). AMSOIL OE Online Product Application Guide [Link](#), has the same Mazda M3 high viscosity index, also recommended.

**Fluid:** After extensive research, the desire to get the best automatic transmission fluid, and the desire to pay the dollars, 10 quarts of 2005 RX8 Mazda Automatic Transmission Fluid M3 were purchased from the Mazda Parts Department. There are lots of stories out there to review [Link](#). Too low viscosity and down shift problems, too high viscosity results in sluggish shift and lower MPG. A twelve year old transmission can be tricky. 2017 Mazda Fluid says M3, see picture. The factor deciding not to drop the transmission pan was at least 2' of clearance under the RX8 is needed to remove the 18 bolts and prepare the surface for a new rubber seal. The old fluid color indicated replacement, there was no burnt smell.

**Fluid Remove & Install:** Got Genuine Mazda Fluid recommended for this 2005 RX8. Deferred filter replacement for the 75K maintenance. Used a hand pump to suck out the old fluid through the dip stick filling used oil quart containers, and replaced exactly what was removed with new 2005 RX8 Mazda Automatic Transmission M3 Fluid. Got 4 quarts out within 10 minutes, filled with 4 quarts, mixed by driving. Got 2 quarts out, the first mixed fluid was pretty pink with a slight brown tint. Filled with 2 quarts and mixed again by driving. Four more quarts will be exchanged in a month. There were no metal particles in old fluid. Local shops wanted \$160-\$175 to replace the fluid. The 10 quarts cost \$80, best price at the Mazda Parts Department. Used a marked funnel to measure how much fluid came out to put exact amount back in. [Link](#)

**DIY Transmission Full Fluid Removal:** Unscrew the return line, screw a [Line Adapter 18MM X 1.5 TO 9/16](#) into the oil cooler's return line output port, put an 9/16" ID hose into an old ATF dump bucket in view for a visual inspection while filling new fluid into the transmission. That will purge the oil cooler. Screw a banjo bolt [18MM-1.50](#) into the return line that goes to the transmission held with an 18 mm nut and 2x 18mm crush washers. Fit a PVC tube from the end of the bolt with a hose clamp. The other end of the PVC tube goes to the output port of an [Oil Extractor Pump](#) \$16.98. A PVC tube on the input side of the Oil Extractor Pump goes into a clean bucket filled with new ATF. Torque banjo bolts to 18 ft-lbs. The election was to remove and replace through the dip stick tube.

**DIY Transmission Filter Replace:** To replace filter, use a plastic scraper and a scotch bright pad on the rubber gasket placement area on the pan and transmission, they will not gauge the metal. Make sure the gasket and filter match. Place a flat cardboard box under the car to protect the concrete. Use aluminum foil to divert ATF from cross members. Use brake cleaner to clean out the transmission pan. Use 3M silicon paste on the pan edge before placing the new gasket. Use brake clean on the bolts. Torque to bolts 5.0 - 6.5 ft-lbs starting from the center and going in a crisscross star pattern. The election was to remove and replace through the dip stick tube.

### GENUINE MAZDA AUTOMATIC TRANSMISSION FLUID TYPE: M3

**Mazda genuine automatic transmission fluid is a unique formulation specifically manufactured to meet the exacting standards of quality established by Mazda.**

*This automatic transmission fluid meets Mazda's M3 specification and is recommended for use in all Mazda vehicles requiring ATF M3. Mazda ATF M3 is formulated to provide maximum performance from Mazda automatic transmissions. Optimum shift quality is maintained through a wide range of conditions and over long periods of use by the additions of special friction modifiers. A high viscosity index fluid with special low temperature characteristics is used to ensure stable operation over a wide temperature range. This allows for easier engine starting and smoother low temperature shifting in cold weather. Special anti-wear characteristics help to protect the transmission from copper corrosion and excessive wear. Transmission seals and "o" rings are protected by the use of special ingredients to prolong life. Always follow equipment manufacturers fluid recommendations.*

Mazda RX8 2004-2008 Section 1300A 02/03 Inlet Manifold (AT) (UIMU – UIML)

