

Service Information

Mazda Motor Corporation

3-1, Shinchi, Fuchu-cho, Aki-gun
Hiroshima 730-8670, Japan
TEL : 81(82)287-5323
FAX : 81(82)287-5220



Category S	Repair Guidance	Ref. No. R041/14A	Page 1 of 7
Coverage <input type="checkbox"/> Distributor only <input checked="" type="checkbox"/> Please inform your dealers		Date Issued May 14, 2014	
Please convey this information to your <input type="checkbox"/> Director <input checked="" type="checkbox"/> General Manager <input checked="" type="checkbox"/> Warranty Dept. <input checked="" type="checkbox"/> Parts Dept. <input checked="" type="checkbox"/> Training Dept. <input checked="" type="checkbox"/> Field Rep.		Date Revised August 26, 2014	
Applicable Model Mazda3 (BL), Mazda6 (GJ), CX-5(KE)		Applicable Countries or Specifications Worldwide	

REVISED

Revision Note: "Applicable model", "BEGINNING VIN & DATE OF MODIFICATION", "REPAIR PROCEDURE" and "WARRANTY INFORMATION" have been changed

Subject: Cracking Noise from Windshield and/or rear window

DESCRIPTION

Some vehicles may exhibit a cracking noise originated at the positioning pins near the top corners of the windshield and/or rear window when driving on uneven road surface with ambient temperatures of approximately minus 10 degrees C or lower and the vehicle cabin not yet being warmed up.

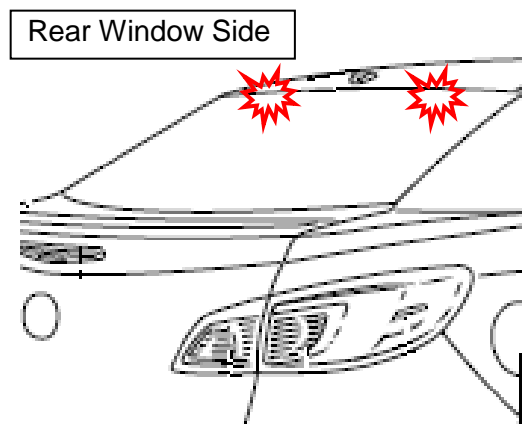
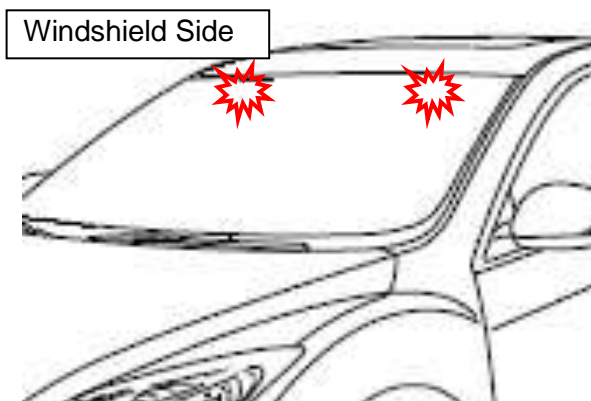

CAUSE

This noise is caused by the windshield and/or rear window locating stopper contacting the panel.

BEGINNING VIN & DATE OF MODIFICATION

Mazda3(BL): Mass production has been discontinued.

Mazda6 (GJ):

Windshield Side:

ADR spec

JM0 GJ **** ** 114247 June 03, 2013

Algerian spec

GJ **** ** 114247 June 03, 2013

General spec

JM6 GJ **** ** 114247 June 03, 2013

JM7 GJ **** ** 114247 June 03, 2013

Israel spec

JMZ GJ **** ** 114247 June 03, 2013

EU spec

JMZ GJ **** ** 140034 June 03, 2013

US spec

JM1 GJ **** ** 125986 June 03, 2013

Rear Widow Side:

ADR spec

JM0 GJ **** ** 119164 August 01, 2013

Algerian spec

GJ **** ** 119164 August 01, 2013

General spec

JM6 GJ **** ** 119164 August 01, 2013

JM7 GJ **** ** 119164 August 01, 2013

Israel spec

JMZ GJ **** ** 119164 August 01, 2013

EU spec

JMZ GJ **** ** 144696 August 01, 2013

US spec

JM1 GJ **** ** 137237 August 01, 2013

CX-5(KE):

ADR spec

JM0 KE **** ** 225624 October 1, 2013

Algerian spec

KE **** ** 225624 October 1, 2013

Chinese spec

JM7 KE **** ** 225624 October 1, 2013

General spec

JM6 KE **** ** 225624 October 1, 2013

JM8 KE **** ** 225624 October 1, 2013

Israel spec

JMZ KE **** ** 225624 October 1, 2013

EU spec

JMZ KE **** ** 251437 October 1, 2013

UK spec

JMZ KE **** ** 163783 October 1, 2013

US spec

JM3 KE **** ** 398378 October 1, 2013

REPAIR PROCEDURE

When you encounter a customer complaint on this concern, cut the end of the stopper and bend the panel at the affected windshield and/or rear window side as per the following procedure.

Windshield Side:

1. Remove the assist handle according to the workshop manual. Refer to ASSIST HANDLE REMOVAL/INSTALLATION.
2. Remove the sun visor according to the workshop manual. Refer to SUNVISOR REMOVAL/INSTALLATION.
3. Partially peel back the seaming welt.
4. Pull out the A-pillar trim from A-pillar referring to the workshop manual.
5. Attach masking tape to the black portion of the windshield around the area you are working to prevent scratches.

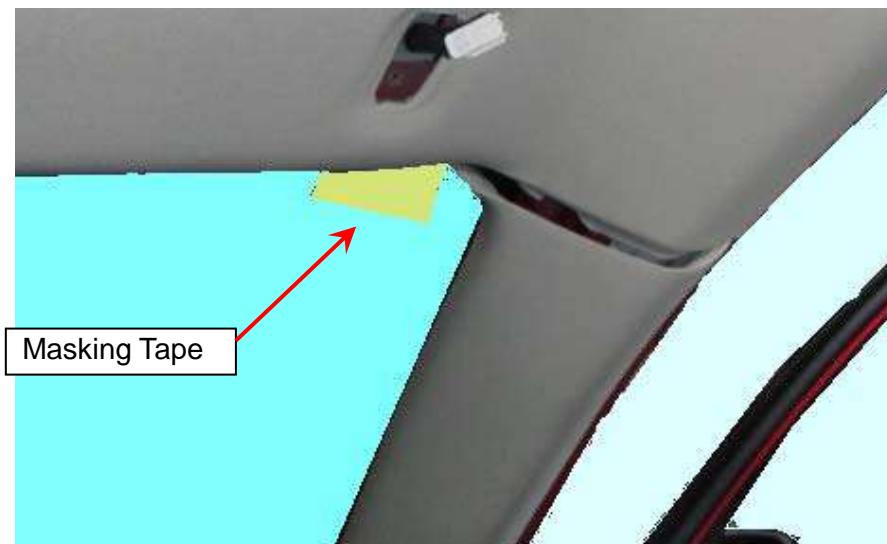

6. Gently pull down on the headliner to provide enough space to insert side cutters.
7. Insert side cutters between the headliner and the reinforcement panel, and cut the end of the pin.

NOTE: * Do not apply excessive force to the pin, or the windshield may crack.
* Avoid any damage on the windshield.

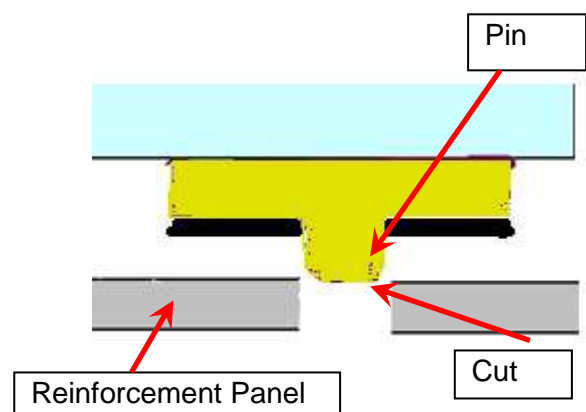
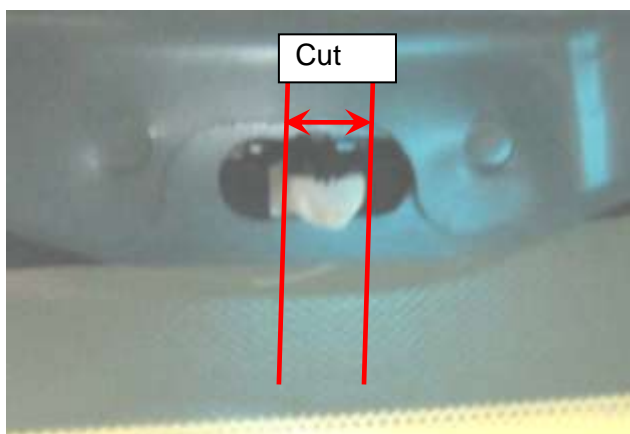

8. Pull down the reinforcement panel to provide clearance between the reinforcement panel and the remainder of the cut pin using a suitable tool (e.g a retaining clip remover). Ensure there is no remaining contact between the pin and reinforcement panel.

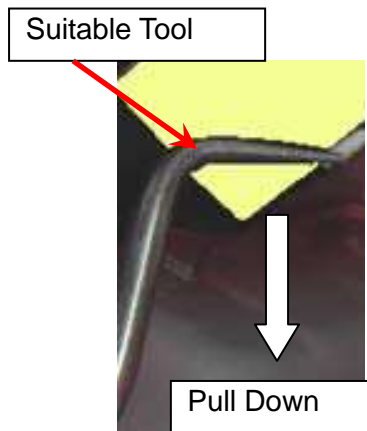

9. Repeat on the other side and reassemble the removed components in the reverse order of removal.

Mazda6 and Mazda3

Rear Window Side: (Only for Sedan)

1. Remove the "C" pillar trim as per the workshop manual. Refer to C-PILLAR TRIM REMOVAL/INSTALLATION.

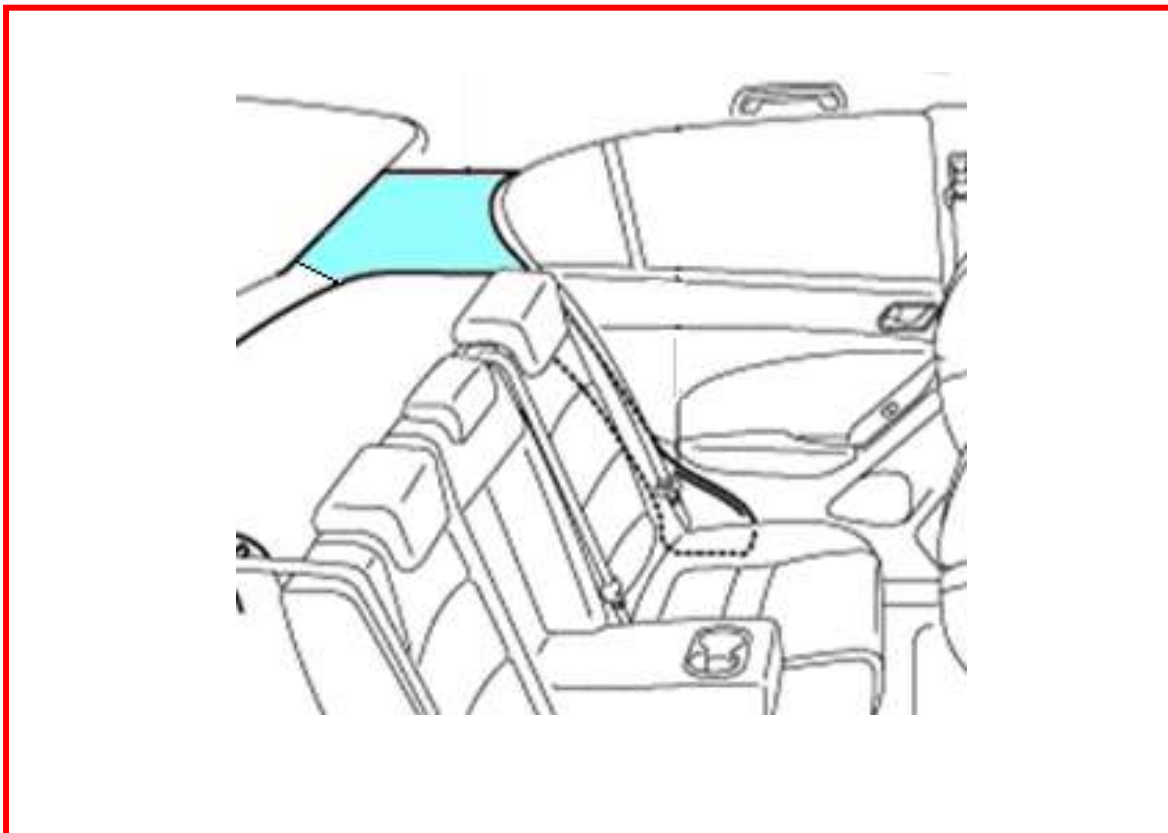

- 2. Remove the clips securing the headliner to the roof panel. Take care when handling the headliner to prevent any dirt or contamination as it can be easily stained.

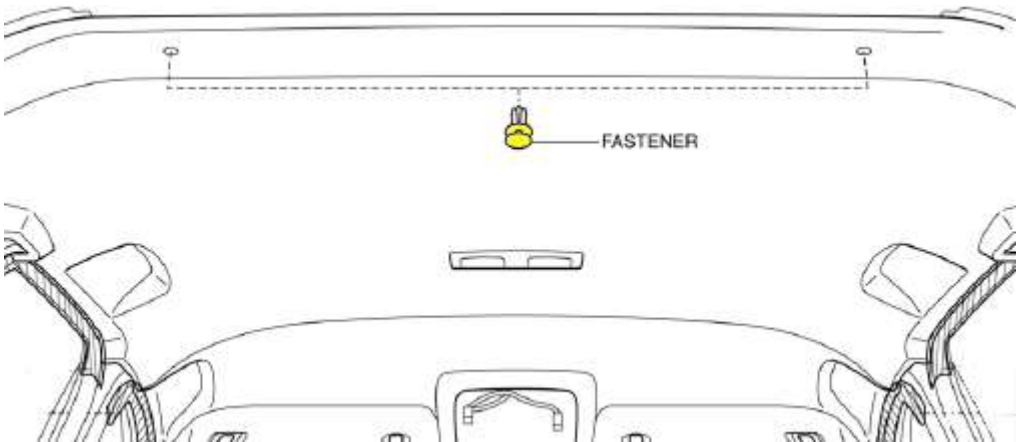

- 3. Attach masking tape to the black portion of the rear window around the area you are working to prevent scratches.
- 4. Gently pull down the headliner to provide enough space to insert side cutters.
- 5. Insert side cutters between the headliner and the reinforcement panel, and cut the end of the pin.

Note: * Do not apply excessive force to the pin, or the rear window may crack.
* Avoid any damage on the rear window.

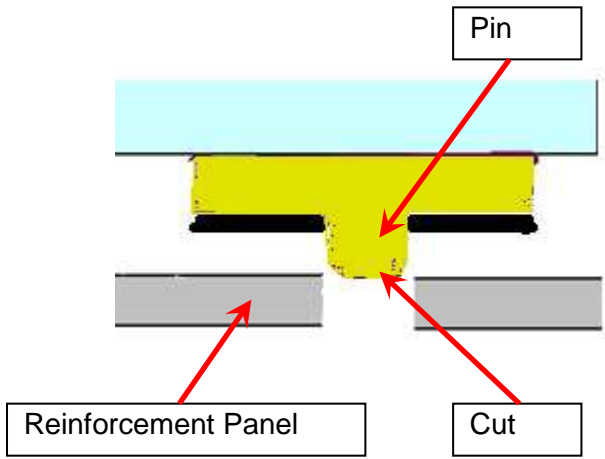
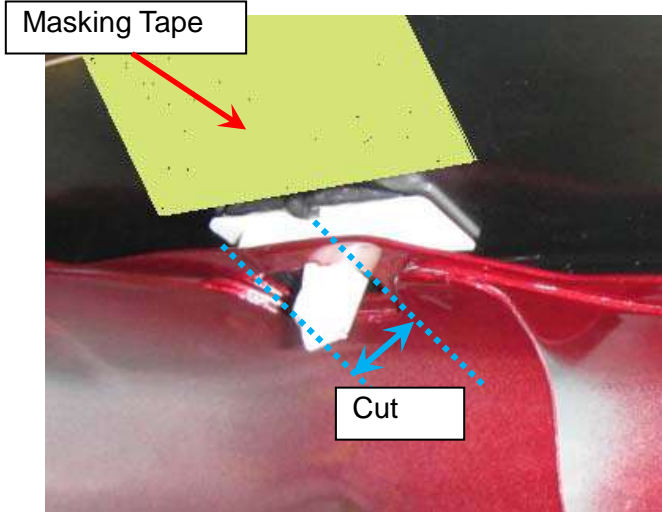

6. Pull down the reinforcement panel to provide clearance between the reinforcement panel and the remainder of the cut pin using a suitable tool (e.g. a retaining clip remover). Ensure there is no remaining contact between the pin and the reinforcement panel.

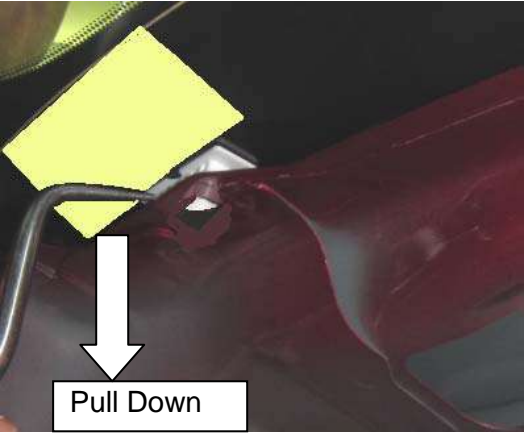

7. Repeat on the other side and reassemble removed components in reverse order of removal.

PART INFORMATION

Part Number	Part Name	Q'ty
D651-68-162A	Clip	2 / For A-pillar 2 / For C Pillar (Only for Mazda3)

WARRANTY INFORMATION

All Models

Windshield Side:

Assembly group	S – Body
Subassembly group	14 – WINDOW GLASSES
Symptom Code	82
Damage Code	97
Causal Part No.	7777-SP-J60
Q'ty	0
Operation No.	XXK7DARX
Labor Hours	0.3 Hrs.(without i-stop) 0.4 Hrs.(with i-stop)
Period Covered	Normal Warranty Period

Note: Claim Clip(s) D651-68-162A as related part.

Mazda3 and Mazda6 (Only for Sedan)

Rear Window Side:

Assembly group	S – Body	
Subassembly group	14 – WINDOW GLASSES	
Symptom Code	82	
Damage Code	97	
Causal Part No.	7777-SP-J60	
Q'ty	0	
Operation No.	XXK7DBRX	
Labor Hours	Mazda3 0.6 Hrs.	Mazda6 0.4 Hrs.
Period Covered	Normal Warranty Period	

Note: Claim Clip(s) D651-68-162A as related part (Mazda3 only).

Windshield and Rear Window Side:

Assembly group	S – Body	
Subassembly group	14 – WINDOW GLASSES	
Symptom Code	82	
Damage Code	97	
Causal Part No.	7777-SP-J60	
Q'ty	0	
Operation No.	XXK7DCRX	
Labor Hours	Mazda3 0.8 Hrs. (without i-stop) 0.9 Hrs. (with i-stop)	Mazda6 0.6 Hrs. (without i-stop) 0.7 Hrs. (with i-stop)
Period Covered	Normal Warranty Period	

Note: Claim Clip(s) D651-68-162A as related part.

Ryu Shimizugawa
Manager, Technical Information Gr.
Technical Service Dept.
Mazda Motor Corporation
2D21811558 (MC Internal Use)