

Service Information

Mazda Motor Corporation

3-1, Shinchi, Fuchu-cho, Aki-gun
Hiroshima 730-8670, Japan
TEL : 81(82)287-5323
FAX : 81(82)287-5220



Category S	Repair Guidance	Ref. No. R027/13C	Page 1 of 7
Coverage <input type="checkbox"/> Distributor only <input checked="" type="checkbox"/> Please inform your dealers		Date Issued April 4, 2013	
Please convey this information to your <input type="checkbox"/> Director <input checked="" type="checkbox"/> General Manager <input checked="" type="checkbox"/> Warranty Dept. <input checked="" type="checkbox"/> Parts Dept. <input checked="" type="checkbox"/> Training Dept. <input checked="" type="checkbox"/> Field Rep.		Date Revised May 8, 2015	
Applicable Model CX-5 (KE), Mazda3 (BM) and Mazda6 (GJ)		Applicable Countries or Specifications Worldwide	

REVISED

REVISION NOTE

- Mazda3 (BM) and Mazda6 (GJ) have been added to the applicable model.
- "REPAIR PROCEDURE" has been completely revised to cover Mazda3 (BM) and Mazda6 (GJ).

Subject: Rattle Noise from Front Door Window Glass

DESCRIPTION

When driving a vehicle with the front door window glass partially opened for about 1 to 10 cm from the closed position, the door window glass causes a rattle noise.

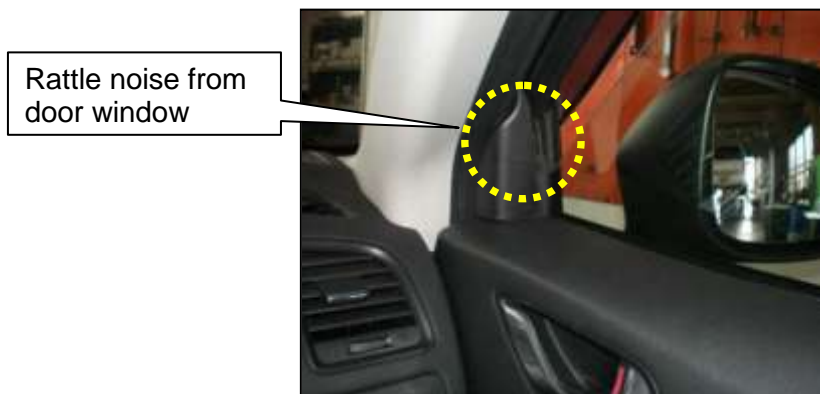

CAUSE

The holding force of glass run channel is not sufficient.

MASS PRODUCTION CHANGE

1. The shape of glass run channel has been changed to increase the holding force.
2. Non-woven fabric sheets have been attached to the glass run channel to increase the holding force.

SUBJECT VIN RANGES

CX-5 (KE): *** KE**** **100001 – 999999 (TBD)
Mazda3 (BM): *** BM**** **100001 – 999999 (TBD)
Mazda6 (GJ): *** GJ**** **100001 – 999999 (TBD)

Note: A few vehicles even after the mass-production changes experience the concern so the ending VINs have not been decided at the moment.

REPAIR PROCEDURE (Completely revised)

When you receive a customer complaint on this concern, verify that the rattle noise disappears when holding the partly opened window glass by hand or when the window is completely closed. If the noise has gone, attach non-woven fabric sheets to the glass run channel to increase the holding force according to the following procedure.

[POSITIONS TO ATTACH NON-WOVEN FABRIC SHEET]

Attach non-woven fabric sheets to Position A, B and C of the glass run channel as shown.

Note: Depending on vehicle types (production change levels), non-woven fabric sheet or resin foam has already been attached to **Position C or Position C & A**. In this case, it is not necessary to additionally attach a non-woven fabric sheet to this position(s).

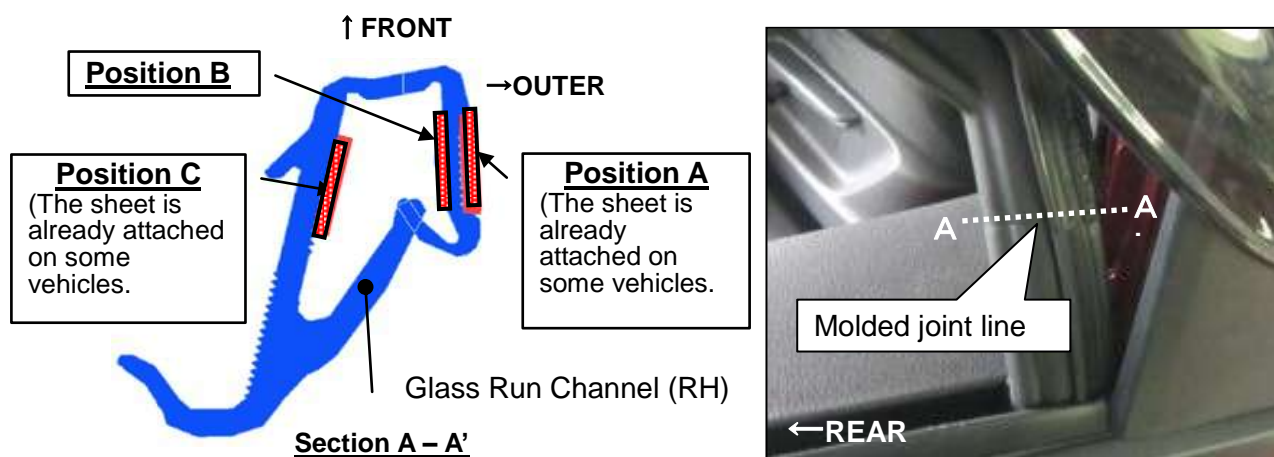

[NON-WOVEN FABRIC SHEET SIZE AND POSITION TO ATTACH ACCORDING TO VEHICLE TYPE (MASS-PRODUCTION CHANGE LEVEL)]

- Attach the specified size of non-woven fabric sheet.
- × A non-woven fabric sheet or a resin foam has already been attached to this position so it is not necessary to attach additionally.

FOR EUROPE

CX-5

Vehicle Type	Production Date Range	VIN Range		Position and Size (t x W x L mm)		
				Position A	Position B	Position C
A	Job#1 - 12/1/28	JMZ KE**** **	100001 - 150422	○(1x7x100)	○(1x7x40)	○(1x7x60)
B	12/1/29 - TBD		150423 - 999999	○(1x7x40)	○(1x7x40)	×

Mazda3 (JAPAN built)

B	Job#1 - 2014/7/1	JMZ BM**** **	100001 - 169778	○(1x7x50)	○(1x7x40)	×
C	2014/7/2 - TBD		169779 - 999999	×	○(1x7x40)	×

Mazda3 (MEXICO built)

C	Job#1 - TBD	3MZ BM**** **	100001 - 999999	×	○(1x7x40)	×
---	-------------	---------------	-----------------	---	-----------	---

Mazda6

C	Job#1 - TBD	JMZ GJ**** **	100001 - 999999	×	○(1x7x40)	×
---	-------------	---------------	-----------------	---	-----------	---

FOR USA

CX-5

Vehicle Type	Production Date Range	VIN Range		Position and Size (t x W x L mm)		
				Position A	Position B	Position C
A	Job#1 - 12/1/28	JM3 KE**** **	100001 - 300112	O(1x7x100)	O(1x7x40)	O(1x7x60)
B	12/1/29 - TBD		300113 - 999999	O(1x7x40)	O(1x7x40)	×

Mazda3 (JAPAN built)

B	Job#1 - 2014/7/1	JM1 BM **** **	100001 - 218352	O(1x7x50)	O(1x7x40)	×
C	2014/7/2 - TBD		218352 - 999999	×	O(1x7x40)	×

Mazda3 (MEXICO built)

B	Job#1 - 2014/6/2	3MZ BM **** **	100001 - 117653	O(1x7x50)	O(1x7x40)	×
C	2014/6/3 - TBD		117654 - 999999	×	O(1x7x40)	×

Mazda6

C	Job#1 - TBD	JM1 GJ **** **	100001 - 999999	×	O(1x7x40)	×
---	-------------	----------------	-----------------	---	-----------	---

FOR ADR/GENERAL/ALGERIA/ISRAEL/CHINA

CX-5

Vehicle Type	Production Date Range	VIN Range		Position and Size (t x W x L mm)		
				Position A	Position B	Position C
A	Job#1 - 12/1/28	JM0 KE**** ** JM6 KE**** ** JM7 KE**** **	100001 - 134693	O(1x7x100)	O(1x7x40)	O(1x7x60)
B	12/1/29 - TBD	JM8 KE**** ** JMZ KE**** **				

Mazda3 (JAPAN built)

B	Job#1 - 2014/7/1	JM0 BM **** ** JM6 BM **** **	100001 - 218352	O(1x7x50)	O(1x7x40)	×
C	2014/7/2 - TBD	JM7 BM **** ** JMZ BM **** **				

Mazda3 (MEXICO built)

B	Job#1 - 2014/6/2	3MZ BM **** **	100001 - 100827	O(1x7x50)	O(1x7x40)	×
C	2014/6/3 - TBD		100828 - 999999	×	O(1x7x40)	×

Mazda3 (THAILAND built)

B	Job#1 - 2014/7/31	MM8 BM **** **	100001 - 104587	O(1x7x50)	O(1x7x40)	×
C	2014/8/1 - TBD		104588 - 999999	×	O(1x7x40)	×

Mazda6

C	Job#1 - TBD	JM0 GJ **** ** JM6 GJ **** ** JM7 GJ **** ** JMZ GJ **** **	100001 - 999999	×	O(1x7x40)	×
---	-------------	--	-----------------	---	-----------	---

[PROCEDURE TO ATTACH NON-WOVEN FABRIC SHEET]

Note: The following procedure shows CX-5 right-side glass run channel. The same procedure is applicable to all models' right and left side glass run channel.

1. Open the door window glass fully.
2. Pull out the glass run channel from the door frame.



3. Select a non-woven fabric sheet of 0.25mm thickness from the "Noise Parts Set" and cut it into sizes necessary for the vehicle in repair. Select appropriate repair according to above VIN table.

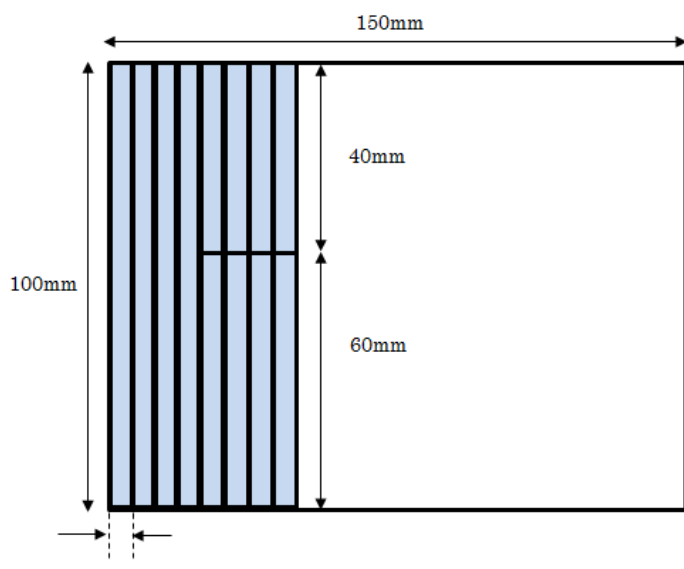

3-1. Cutting sample

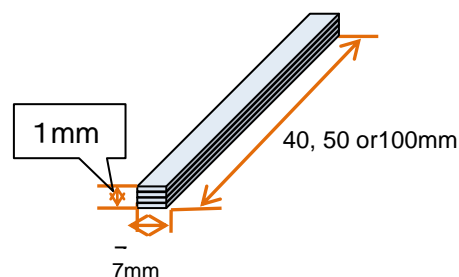

4. Degrease the glass run channel where the sheets should be attached.
Note: Depending on the vehicle type, degreasing is not necessary for C or C and A if a non-woven fabric sheet or a resin foam has already been attached there.

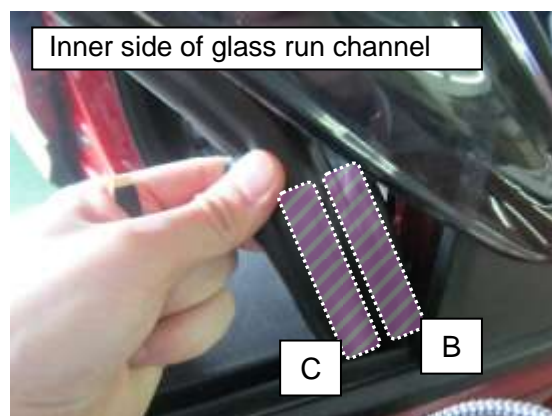
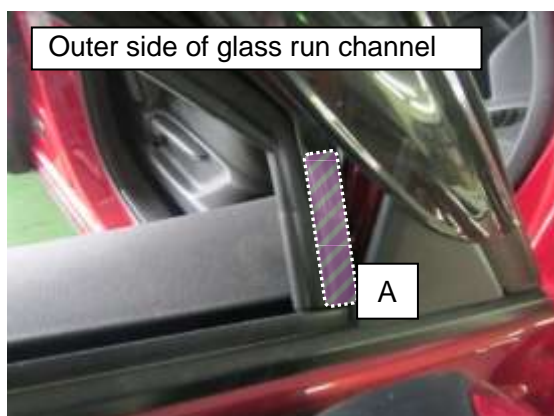

5. Apply primer (silicone remover) to the area where the sheets should be attached.
Note: Procure the primer locally.
Recommendation: 3M product K-540NT, K-500 or 4298UV. If this product cannot be procured, any silicone remover suitable for plastics can be used.

6. According to the vehicle type, attach the non-woven fabric sheet(s) by the following steps.

1) Attach the sheet of the below size to **Position A**.

Vehicle Type	Sheet Size (mm)
CX-5 TYPE A:	1x7x100
CX-5 TYPE B:	1x7x40
Mazda3 TYPE B:	1x7x50

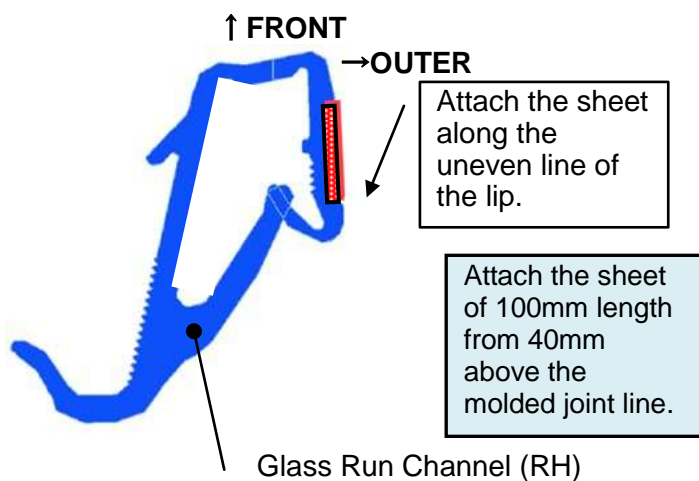

For CX-5 Type A

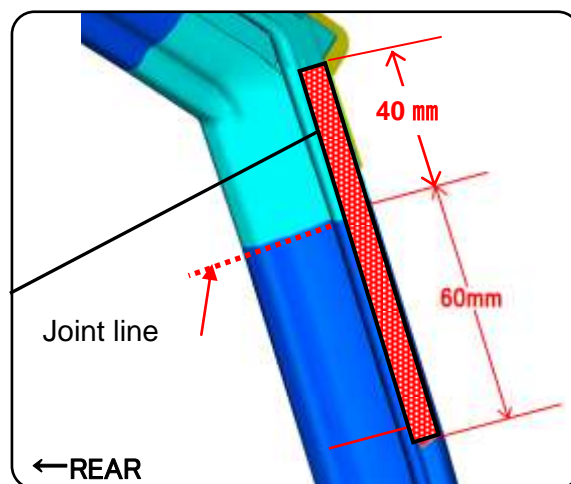

For CX-5 Type B

Attach the sheet of 40mm length right above the molded joint line.

This sheet has already been attached to this portion.

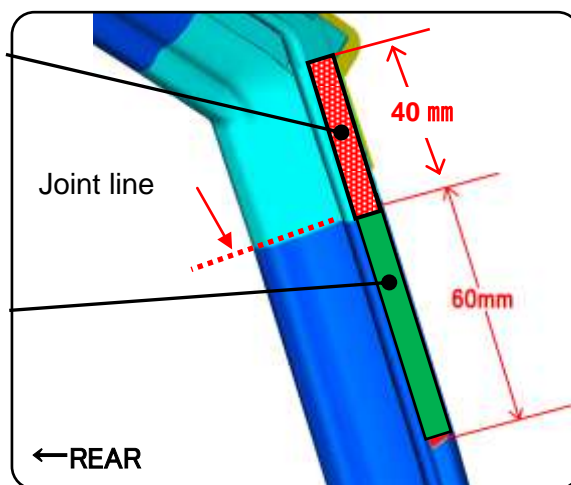

For Mazda3 Type B

Attach the sheet of 50mm length right below the molded joint line.

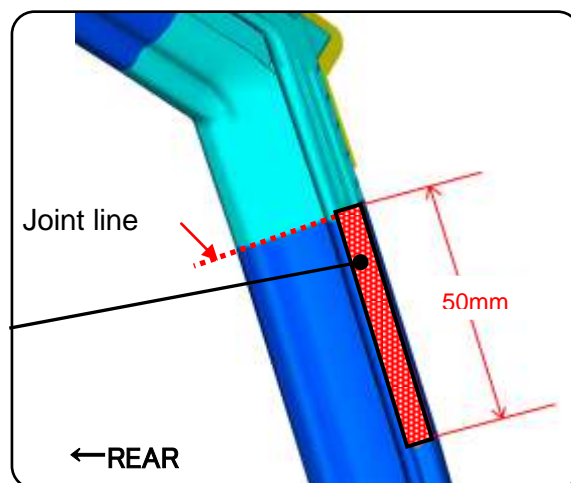

2) Attach the sheet of the below size to **Position B.**

Vehicle Type	Sheet Size (mm)
CX-5 ALL:	1x7x40
Mazda6 ALL:	1x7x40
Mazda3 ALL:	1x7x40

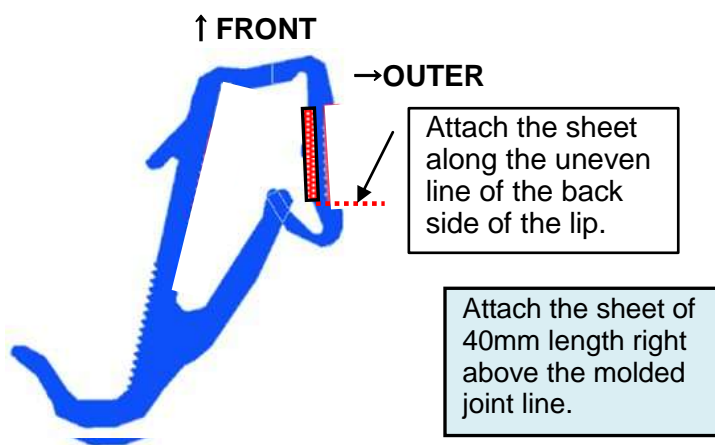

For All Vehicle Types

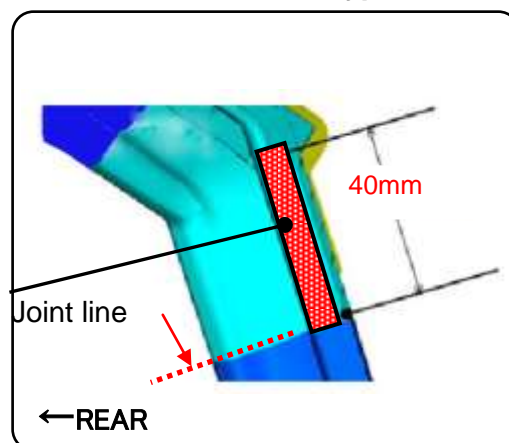

Note: The picture is perspective view. In the actual work, attach the sheet by flipping the outer lip

3) Attach the sheet of the below size to **Position C.**

Vehicle Type	Sheet Size (mm)
CX-5 TYPE A:	1x7x60

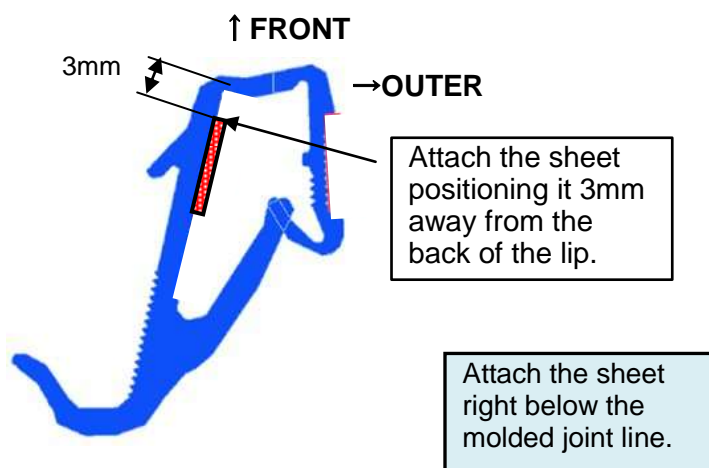

For CX-5 Type A

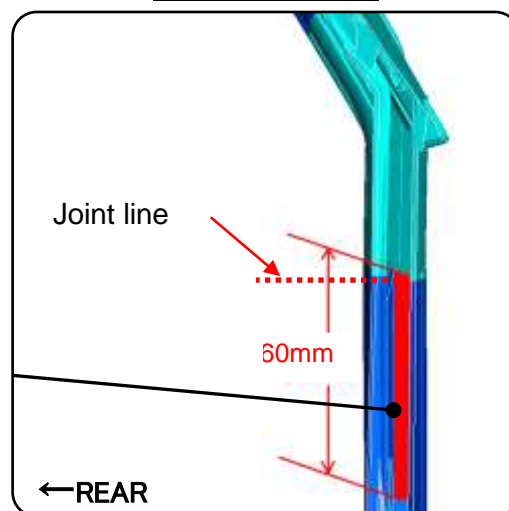

Note: The picture is perspective view. In the actual work, attach the sheet by flipping the outer lip

7. Install the glass run channel to the original position.
8. Verify there is no abnormality when door window glass is operated up and down.
9. Repair the other side glass run channel if needed in the same way.

PART INFORMATION

Part Number	Part Name	Q'ty	Remark
TA01-76-100	Noise parts set	1	Use non-woven fabric of 0.25mm thickness (One sheet can repair 2 to 40 vehicles depending on the vehicle type.)

WARRANTY INFORMATION

Assembly group	S – Body	
Subassembly group	14 – WINDOW GLASSES	
Symptom Code	82	
Damage Code	97	
Causal Part No.	****-59-605*/****-58-605* (Check Parts Catalogue for the part number of “Glass Run channel” applicable to the VIN in repair.)	
Q'ty	0	
Operation No.& Labor Hours	<p>■ Attach sheet to Position B only.</p> <p>■ Attach sheet to Position A & B, or</p> <p>■ Attach sheet to Position A, B & C.</p>	<p>XXL41XRX :0.2H (One side) XXL42XRX :0.3H (Both sides)</p> <p>XXJ5CXRX :0.3H (One side) XXJ5DXRX :0.4H (Both sides)</p>
Period Covered	Normal Warranty Period	

Note:

- For noise part set, claim as related part at the first time repair.
- For the primer, please submit them at the first claim as sublet amount with the sublet code “Z9” or “X”.

Ryu Shimizugawa
Manager, Technical Information Gr.
Technical Service Dept.
Mazda Motor Corporation
2C71701431 (MC Internal Use)