

# Service Information

Mazda Motor Corporation

3-1, Shinchi, Fuchu-cho, Aki-gun  
Hiroshima 730-8670, Japan  
TEL : 81(82)287-5323  
FAX : 81(82)287-5220



Category <b>T</b>	<b>Technical</b>	Ref. No. E010/14	Page 1 of 3
Coverage <input type="checkbox"/> Distributor only <input checked="" type="checkbox"/> Please inform your dealers		Date Issued May 12, 2014	
Please convey this information to your <input type="checkbox"/> Director <input checked="" type="checkbox"/> General Manager <input checked="" type="checkbox"/> Warranty Dept. <input checked="" type="checkbox"/> Parts Dept. <input checked="" type="checkbox"/> Training Dept. <input checked="" type="checkbox"/> Field Rep.		Date Revised	
Applicable Model  Mazda3(BM), Mazda6 (GJ) and CX-5(KE)		Applicable Countries or Specifications  Worldwide	

## Subject: Multiple Electrical Malfunctions after replacing Front Fender Stay by body repair

### DESCRIPTION

Several reports of multiple electrical malfunctions, that occurred after having replaced the front fender stay during body repair, were received. The cause is poor ground of the front harness, caused by improper replacement work of the front fender stay.

This Service Information introduces the occurrence examples and the front fender stay installation caution.

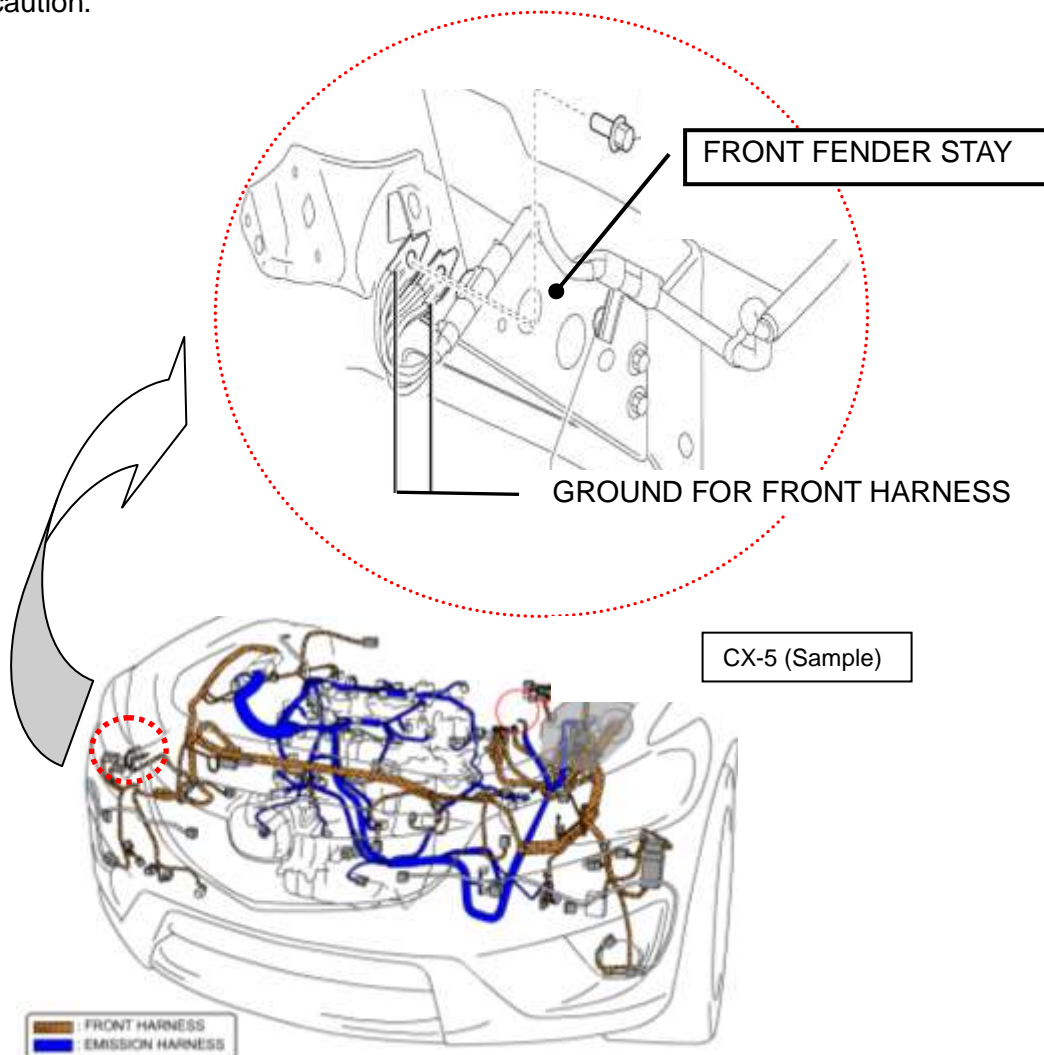

## OCCURRENCE EXAMPLES

### (SYMPTOM)

#### Vehicle A (CX-5 (KE))

##### Symptom 1:

- The customer states that the headlight flashed on and off, the check engine light illuminated, the heater blower stopped operation and then the engine stalled at the end.
- At the time of the vehicle being brought to the workshop, the engine cranked weakly and did not start. After battery charging, the engine starts and the symptoms related to headlight and heater blower operation can be duplicated.

##### Symptom 2:

- The customer states the engine stalled while driving and did not restart.
- The workshop inspection found that it is impossible to identify the vehicle by M-MDS, the electric cooling fan stays on, the ignition cannot be turned off by one operation and multiple warning lights illuminate in the instrument cluster.

#### Vehicle B (Mazda6 (GJ))

- The customer states that multiple warning lights illuminate in the instrument cluster while driving.
- The workshop inspection found several DTCs stored in multiple modules' memory.  
(C0023:62, C1001:92, U0121:00[EPS], U0121:00[IC], U0121:00[SCB], U0121:00[PCM], U0121:00[SSU], U0401[BSM], U0415:00, U2005:86[FSC])

#### Vehicle C (Mazda3 (BM))

- Immediately after body repair (front fender stay) the ABS, Brake, DSC and TPMS warning lights illuminate in the instrument cluster.

### (CAUSE)

At all four vehicles the front fender stay was replaced by body repair previously, and inspection found that the newly installed fender stay was painted at the area where the bolt D is seated, causing poor ground of the front harness.

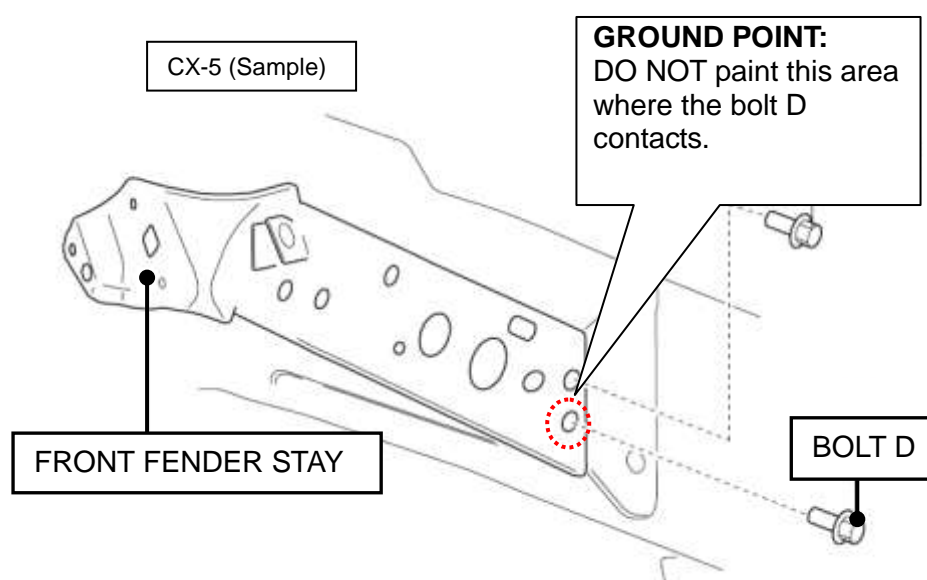

Reinstallation of the front fender stay after sanding off the paint at the bolt D contact area solved all the problems.

### FRONT FENDER STAY NEWLY REPLACE NOTE

When replacing the front fender stay, make sure to follow the following caution.  
For the details, see the section of "FRONT FENDER STAY REMOVAL/INSTALLATION" in the workshop manual of each model.

#### **CAUTION:**

If the bolt D contact area is painted when the front fender stay is newly replaced, it could cause a malfunction in the PCM. Before painting a newly replaced part, protect the bolt D contact areas with masking tape as shown in the figure.

#### **NOTE:**

After installing the bolt D, apply touch-up paint to the exposed base material area of the front fender stay.

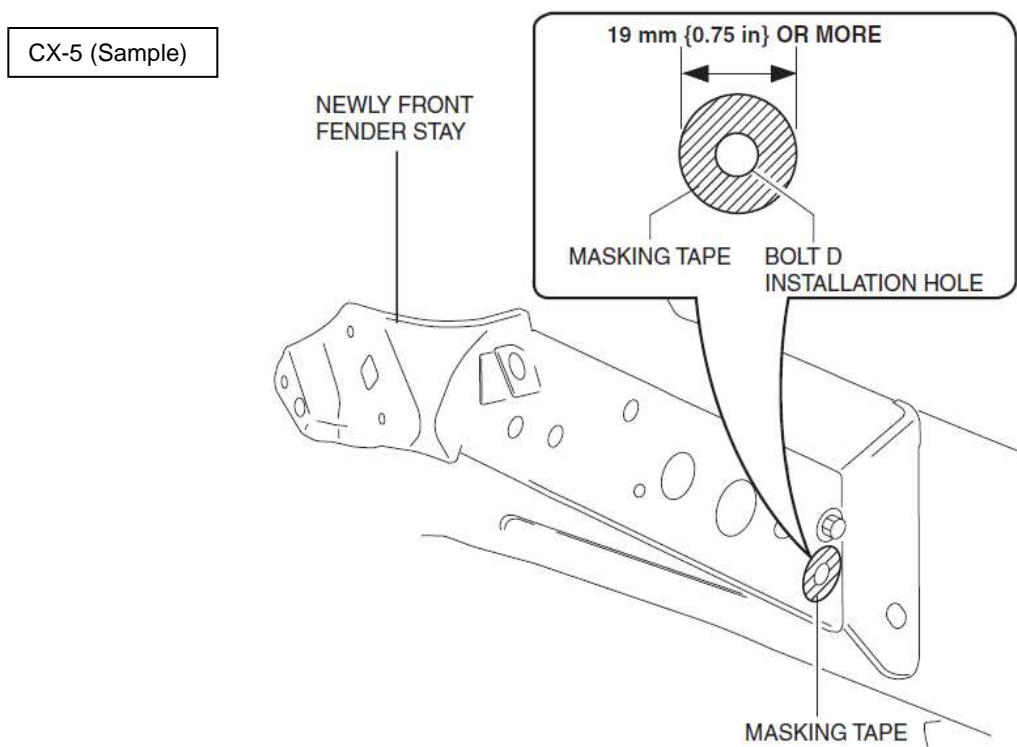

Ryu Shimizugawa  
Manager, Technical Information Gr.  
Technical Service Dept.  
Mazda Motor Corporation