

Service Information

Mazda Motor Corporation

3-1, Shinchi, Fuchu-cho, Aki-gun
Hiroshima 730-8670, Japan
TEL : 81(82)287-5323
FAX : 81(82)287-5220



Category S	Repair Guidance	Ref. No. R038/14	Page 1 of 3
Coverage <input type="checkbox"/> Distributor only <input checked="" type="checkbox"/> Please inform your dealers		Date Issued April 25, 2014	
Please convey this information to your <input type="checkbox"/> Director <input checked="" type="checkbox"/> General Manager <input checked="" type="checkbox"/> Warranty Dept. <input checked="" type="checkbox"/> Parts Dept. <input checked="" type="checkbox"/> Training Dept. <input checked="" type="checkbox"/> Field Rep.		Date Revised	
Applicable Model Mazda3 (BM)		Applicable Countries or Specifications Worldwide	

Subject: Side(s) of Rear Seat Cushion is loose

DESCRIPTION

Some customers may complain that the side(s) of rear seat cushion looks floating above the floor, or it wobbles when lifting by hand.

Looks floating above floor carpet



It wobbles when lifting by hand.



CAUSE

Due to product variation of the rear seat cushion, some may have a larger clearance between the cushion and the floor carpet.

MASS PRODUCTION CHANGE

TBD

BEGINNING VIN & DATE OF MODIFICATION

<p>US spec. JM1 BM **** ** TBD (2014MY)</p> <p>EU spec. JMZ BM **** ** TBD</p> <p>Israel Spec. JMZ BM **** ** TBD</p>	<p>ADR spec. JM0 BM **** ** TBD</p> <p>General spec. JM6 BM **** ** TBD JM7 BM **** ** TBD</p>
--	--

REPAIR PROCEDURE

When you receive a customer complaint on this concern, fix the both sides of rear seat cushion to the floor carpet by using Velcro tapes. Refer to the below procedure.

1. Remove the rear seat cushion according to the instructions in the workshop manual "REAR SEAT CUSHION REMOVAL/INSTALLATION".
2. Turn over the rear seat cushion and confirm the locations to attach Velcro tapes shown in the below figures.

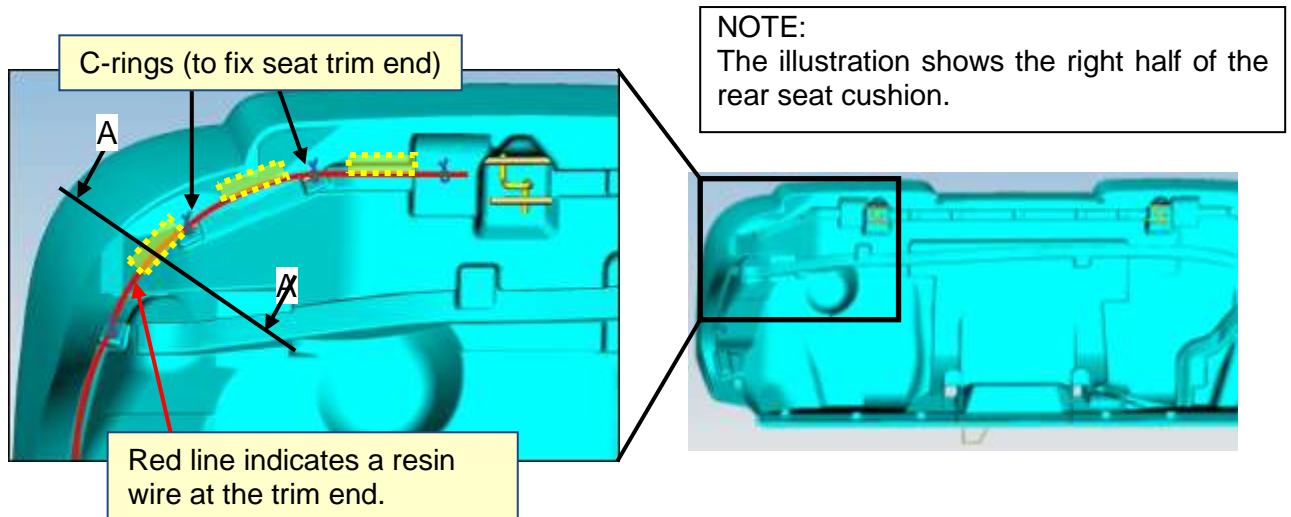

3. Attach 3 Velcro tapes (BHY1-88-472) as shown in the figures.

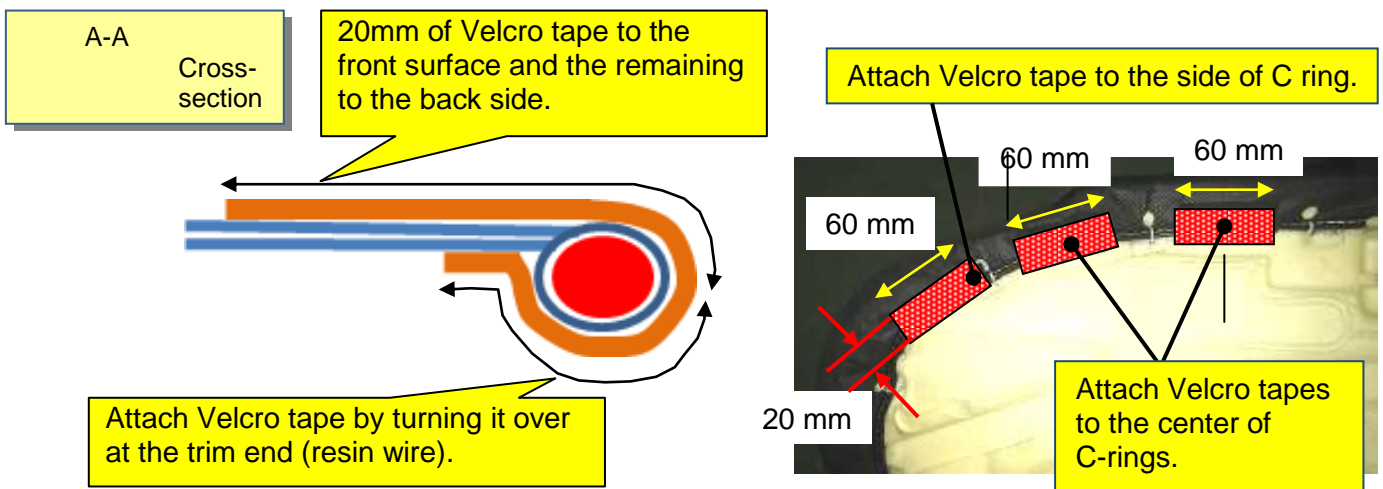

4. Attach Velcro tapes to the opposite side of rear seat cushion by the same procedure.
5. Attach two layers of the felt (BHY1-88-093) to the back side of rear seat cushion as shown in the figure.

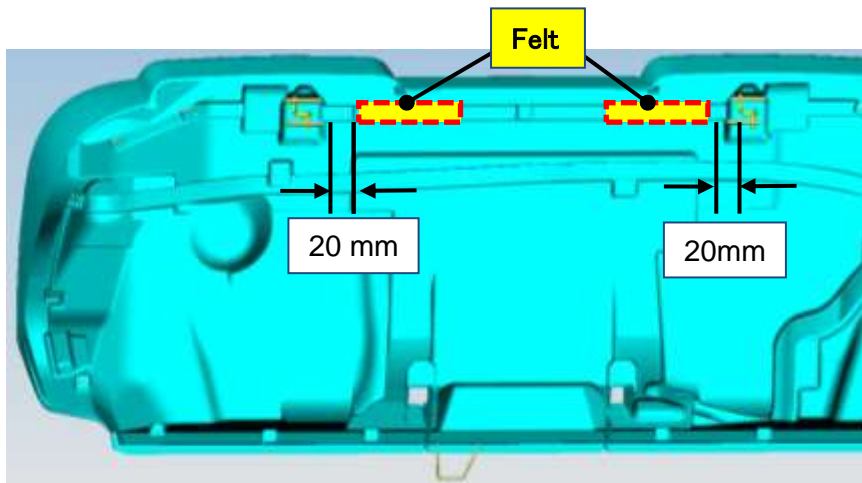

6. Install the rear seat cushion in the reverse order of removal.
7. Push both sides of rear seat cushion by hand to fix the Velcro tapes to the floor carpet.



8. Verify the repair.

PARTS INFORMATION

Part Number	Part Name	Q'ty	Note		
BHY1-88-472A	Velcro Tape	6	60x30mm		Requires 6 pieces per repair
BHY1-88-093	Felt	2	120x30mm (Thickness:3mm)	2 pieces in box	Requires 2 sets (4pieces) per repair

WARRANTY INFORMATION

Assembly group	S - Body
Subassembly group	09 - SEATS & SEAT BELTS
Symptom Code	89
Damage Code	97
Causal Part No.	****-57-200*** (Rear seat cushion)
Q'ty	0
Operation No. & Labor Hours	XXK5EXRX & 0.3H
Period Covered	Normal warranty period

Note: Submit BHY1-88-093 and BHY1-88-472A as related part number.

Ryu Shimizugawa
Manager, Technical Information Gr.
Technical Service Dept.
Mazda Motor Corporation
2DA2814218 (MC Internal Use)