

© 2012 Mazda Motor of America, Inc.

Subject: POOR APPEARANCE OF GLOVE COMPARTMENT	Bulletin No: 09-021/12
	Last Issued: 05/23/2012

APPLICABLE MODEL(S)/VINS

2013 CX-5 vehicles with VINs lower than JM3KE*****111865 (produced before March 5, 2012)

DESCRIPTION

Some vehicles may have a difference in gap clearance (see example shown below) between the left and right sides of the glove compartment, which causes a poor appearance concern. The uneven gaps may be caused by the incorrect tightening order of the lower panel screws.

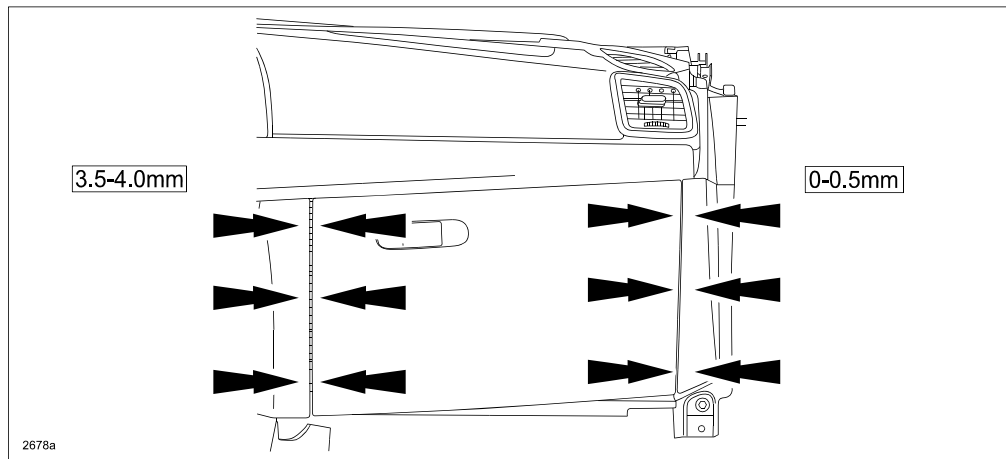

The tightening order of the lower panel screws has been clearly specified at production to eliminate this concern.

Customers having this concern should have their vehicle repaired using the following repair procedure.

REPAIR PROCEDURE

1. Verify the customer concern.
2. Remove the glove compartment according to the online instructions on MS3 or the Workshop Manual (section 09-17 GLOVE COMPARTMENT REMOVAL/INSTALLATION).
3. Remove the front side trim according to the online instructions on MS3 or the Workshop Manual (section 09-17 FRONT SIDE TRIM REMOVAL/INSTALLATION).
4. Loosen the lower panel screws (1) and (2) and verify if the lower panel moves to the left or right.

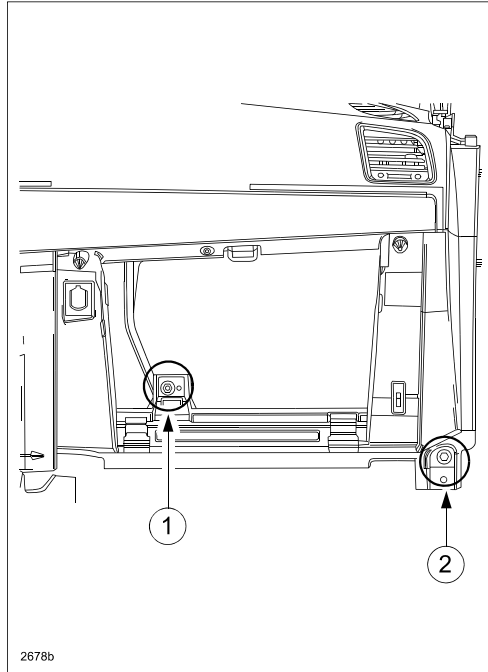

5. Depending on the movement of the lower panel, repair it as follows:
- If it moves to the left or right, tighten screw (1) first and then screw (2).
 - If it does not move, apply force to the lower panel in the direction of the large arrow below and move it about 1-2 mm. While keeping this position, tighten screw (2) first and then screw (1).

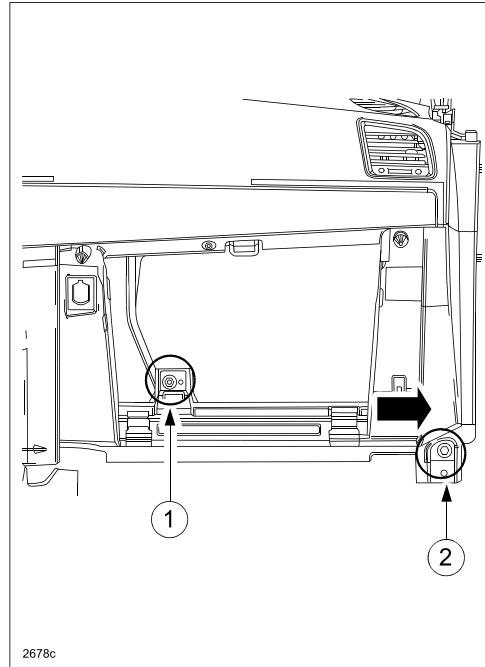

6. Re-assemble the glove compartment in the reverse order of removal.
7. Verify repair.

WARRANTY INFORMATION

NOTE:

- This warranty information applies only to verified customer complaints on vehicles eligible for warranty repair.
- This repair will be covered under Mazda's New Vehicle Limited Warranty term.
- Additional diagnostic time cannot be claimed for this repair.

Warranty Type	A
Symptom Code	89
Damage Code	9H
Part Number Main Cause	KD45-64-260 -02
Quantity	0
Operation Number / Labor Hours:	XXH3HXAX / 0.2 Hrs.