

Subject: NEW MODEL SERVICE CAUTIONS	Bulletin No: 00-003/12
	Last Issued: 12/11/2012

APPLICABLE MODEL(S)/VINS

2014 Mazda6

DESCRIPTION

This Service Information is being issued to advise dealers about the following service cautions for the 2014 Mazda6. Ensure that all appropriate dealer personnel have been advised of this service information:

- Automatic Transaxle Oil
- Spark Plug
- Front Bumper Removal
- Engine Oil
- Tire Pressure Monitoring System (TPMS)
- Navigation System
- Manual Transaxle Oil
- Kickdown Switch (ATX)
- Maintenance Monitor

SERVICE CAUTIONS

Automatic Transaxle Oil:

Only use "Automatic Transmission Fluid (ATF) FZ" for SKYACTIV-DRIVE. "ATF-FZ" is a low viscosity formula with less friction for better fuel economy. If an ATF other than "ATF-FZ" is used in the SKYACTIV-DRIVE ATX, the performance and reliability cannot be guaranteed. Any resulting damage will not be covered by warranty.

NOTE:

- ATF-FZ is colored blue, for easy identification. For ATX that requires ATF-FZ, "FZ" is marked on the dipstick as shown below.
- Flushing machines that "recondition" the existing ATF should never be used.
- A/T oil cooler flush is not required.

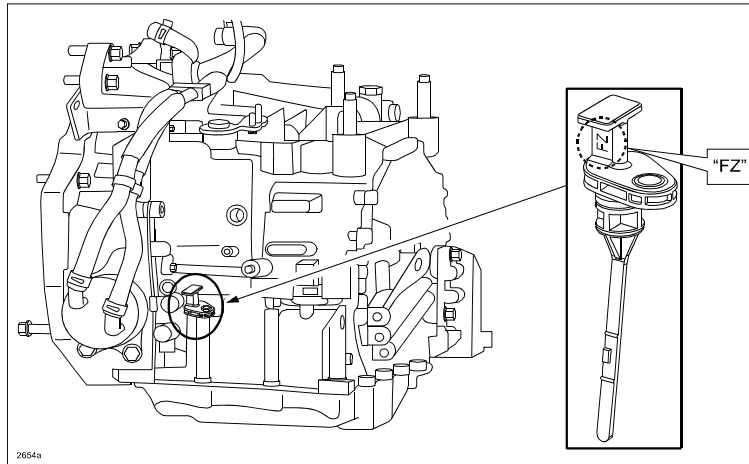

Engine Oil:

Only use the following engine oil for the SKYACTIV-G 2.5 engine.

Engine Oil	For U.S.A. and Canada	SAE 0W-20
	Except U.S.A. and Canada	SAE 5W-30

Manual Transaxle Oil:

GL-4 (75W-80) for the existing MTX can also be used for the SKYACTIV-MT.

Spark Plug:

Always make sure to use the designated spark plugs for SKYACTIV-G 2.5 engine. Usage of general nickel or iridium plugs for SKYACTIV-G could result in engine knocking, MIL illumination and/ or poor drivability.

Tire Pressure Monitoring System (TPMS):

The tire pressure monitoring system monitors the tire pressure based on the signal from the ABS wheel-speed sensors on each wheel. When any of the services below are performed, **BE SURE TO INITIALIZE THE TPMS BEFORE DRIVING THE VEHICLE** by pushing and holding the TPMS Set Switch on the dash (until the TPMS warning light flashes two times and the warning beep sounds once)

The TPMS must be initialized in the following cases:

- Tire pressures have been adjusted in one or more tires.
- Tires have been rotated.
- Tires or wheels have been replaced.
- The vehicle's battery cable has been disconnected for any reason.
- The vehicle's battery has been discharged.
- The DSC HU/CM connector has been disconnected for any reason.

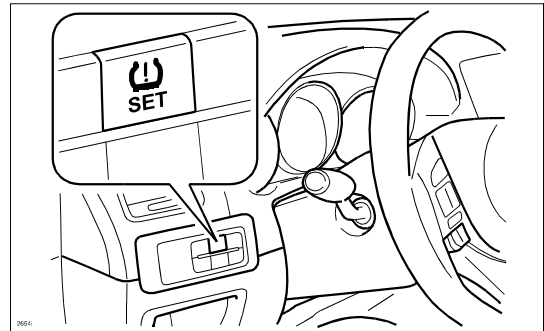

Kickdown Switch (ATX):

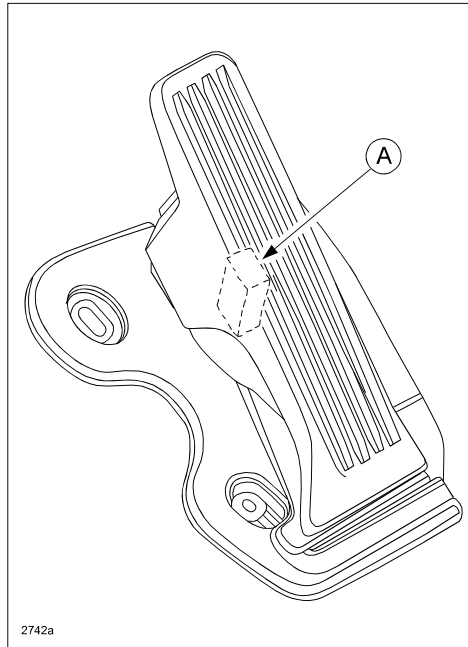

A kickdown switch (A) has been adopted to determine that the customer has fully depressed the throttle pedal for maximum acceleration. A load can be felt while the accelerator pedal is being depressed and when it is further depressed the kickdown switch is activated. A click is felt when the kickdown switch is activated.

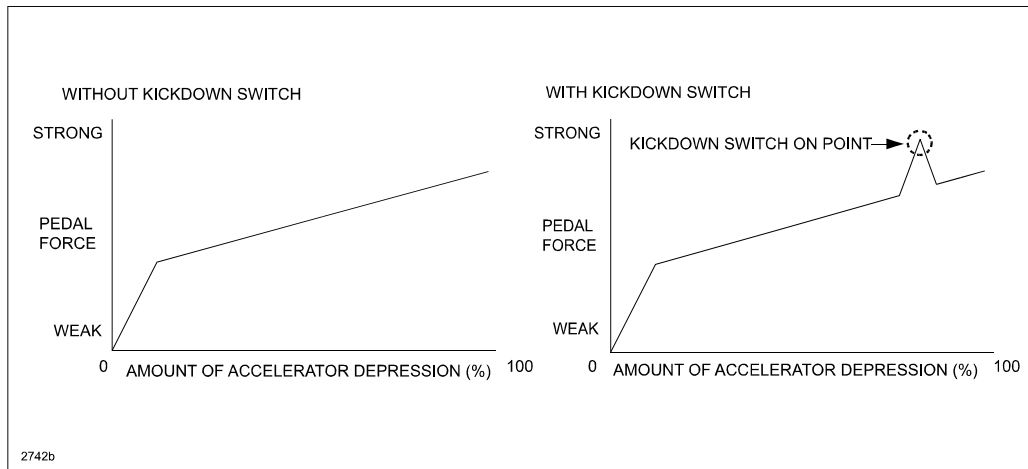

The driver can control the kickdown by knowing the amount of accelerator depression. The kickdown switch is only a measure of the kickdown. An electrical signal is not transmitted by the kickdown switch turning on/off, and vehicle control is not affected.

Front Bumper Removal:

Pull the front bumper slider (A) in direction of arrow (2) as shown in the figure, while removing the edge of the front bumper (B) in the direction of the arrow (1) shown in the figure.

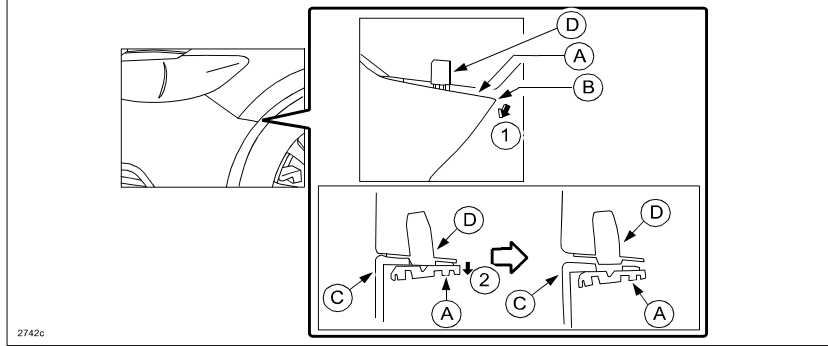

Pull the edge of the front bumper (B) in the direction of the arrow (3) as shown in the figure, and then remove tabs (H).

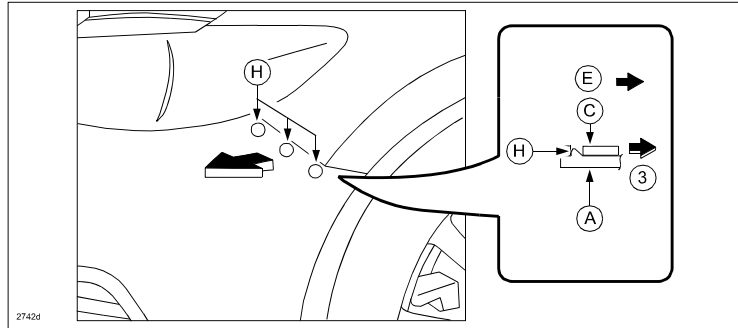

If you pull the edge of the front bumper (B) to outside of vehicle (E) before grommet (D) removal, the fastening part of front bumper could be broken (F).

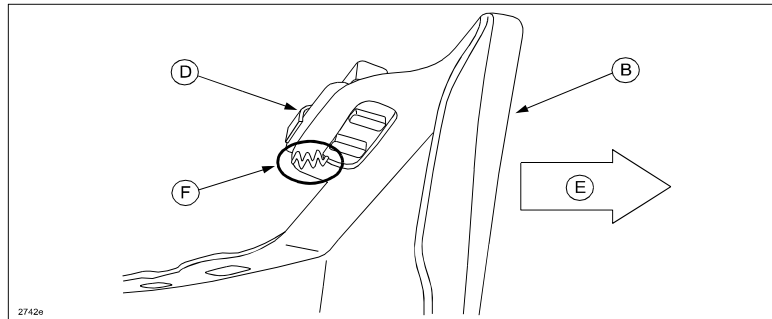

- A - Front Bumper Slider
- B - Edge Of The Front Bumper
- C - Front Bumper
- D - Grommet
- E - Outside Of Vehicle
- F - Could Be Broken
- H - Tab

Navigation System:

The navigation has a function called “Latest Map Guarantee” (LMG), which provides complimentary map updates for a limited period of time.

When a starting condition for LMG (i.e. destination setup) is performed, the internal timer automatically starts the clock for the time period. Therefore, make sure NOT to operate the navigation when the vehicle is received. Only operate the navigation before handing over the vehicle to the customer to ensure they get usage of the full time period of LMG.

NOTE: It is not possible to stop the clock for LMG once it has started.

Refer customer to www.mazdausa.com/navigation for more information.

Maintenance Monitor:

When the preset maintenance period approaches, the maintenance monitor displays a message on the LCD display (A) in the instrument cluster to inform the driver.

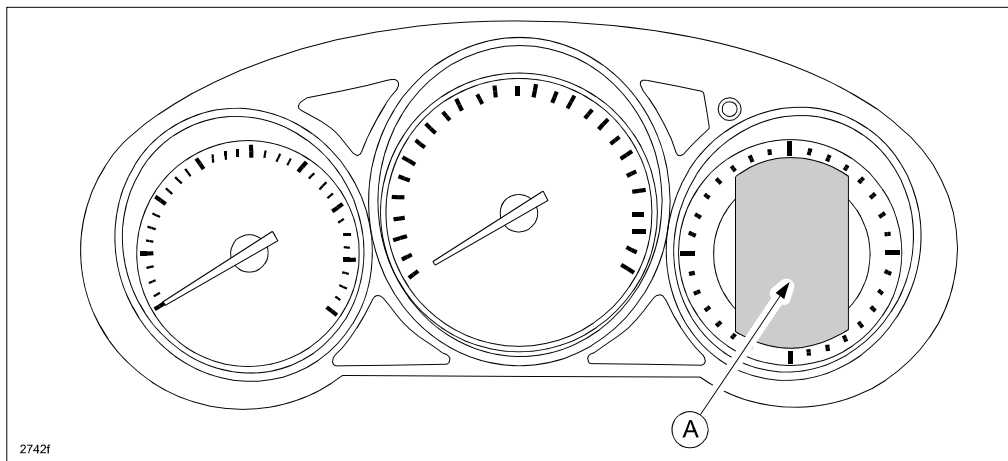

Maintenance settings for the scheduled maintenance, tire rotation, tire pressure and maintenance display/non-display can be set according to user option. Refer to the Workshop Manual for the setting procedure. The initial default setting is Off.