





# GENUINE FOG LAMP BRACKET

## INSTALLATION AND USER'S INSTRUCTIONS

Thank you for purchasing a genuine Mazda accessory.  
Before removal and installation, be sure to thoroughly read these instructions.  
Please read the contents of this booklet in order to properly install and use the fog lamp bracket. Your safety depends on it.  
Keep these instructions with your vehicle records for future reference.

### **WARNING**

- There are several  **WARNING** and  **CAUTION** sections in this booklet concerning safety when installing or removing the fog lamp bracket. Always read and follow them in order to prevent injuries, accidents, and possible damage to the vehicle.
  -  **WARNING:** Indicates a situation in which serious injury or death could result if the warning is ignored.
  -  **CAUTION:** Indicates a situation in which bodily injury or damage to the vehicle could result if the caution is ignored.
- Do not modify the fog lamp bracket.
- Do not install the fog lamp bracket in any way other than described in the following instructions.
- If in any doubt, please ask your Mazda dealer to install the accessory in order to prevent errors in installation.
- If you have any questions about the use of the accessory, ask your Mazda dealer for proper advice before using it.
- Mazda and its suppliers are not responsible for injuries, accidents, and damage to persons and property that arise from the failure of the dealer or installer to follow these instructions.
- To ensure safety and reliability of the work, installation, removal and disposal work must be carried out by an Authorized Mazda Dealership.
- Be careful not to lose removed parts, and be sure that they are kept free from scratches, grease or other dirt.

**PART NAME: FOG LAMP BRACKET**  
**PART NUMBER: QSEA 51 68Z**  
**VEHICLE: Mazda RX-8**  
**(Vehicles with MAZDASPEED front bumper face)**

### NOTE

#### To the dealer

- Please turn over these instructions to the customer after installation.

#### To the customer

- Keep these instructions after installation. The instructions may be necessary for installing other optional parts or removal of this accessory.
- Should the vehicle or this accessory be resold, always leave these instructions with it for the next owner.

# 1 INSTALLATION VIEW

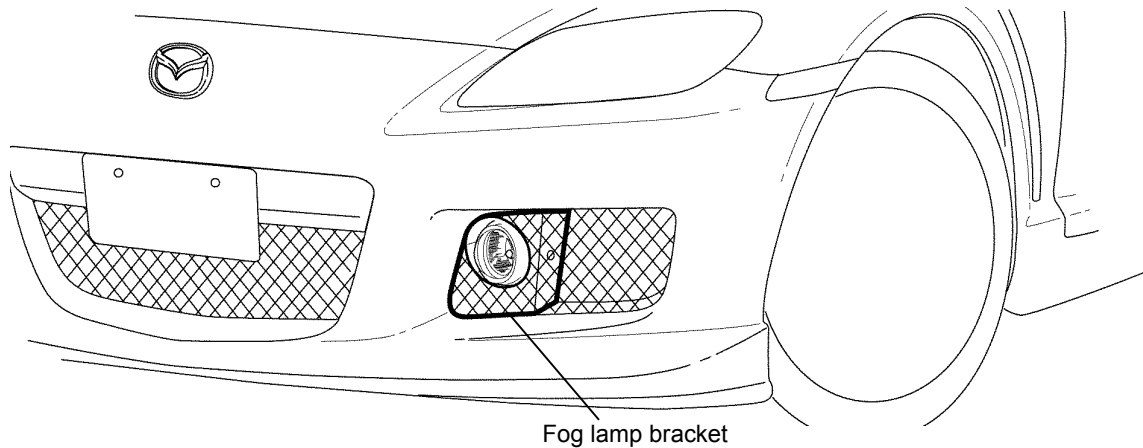

# 2 PARTS

### Note

- Verify that the kit includes all the following parts and that the parts are free of dirt, scratches, or damage.

Part	Part name	Spec	Qty.	Part	Part name	Spec	Qty.
	Fog lamp bracket (RH, LH)	Steel, black	1 ea.		Truss screw	M5 x 15	6
	Flange nut	M5	6		Speed nut	-	2
	Screw	M5 x 20	2		Spring washer	M5, black	6
	Plain washer	M5, black	12		Collar	-	2
	Installation and user's instructions	Paper	1		Template	Paper, A3 size	2

### ⚠ CAUTION

- When fog lamps are not installed, a fog lamp set is necessary to install the fog lamp bracket. Purchase the foglights (FE01 V7 220, FE02 V7 220, or FE03 V7 220) separately.

### 3 BEFORE INSTALLATION

#### REQUIRED TOOLS

Prepare the following tools or items before installation.

- ★ Clean rags      ★ Isopropyl alcohol (IPA)      ★ Phillips screwdriver      ★ Fastener remover
- ★ Masking tape      ★ Round file      ★ Drill      ★ Drill bit (3 mm, 6 mm, 7 mm)
- ★ Oil-based pen      ★ Nipper      ★ Pliers      ★ Needle      ★ Wrench (10 mm)
- ★ Hacksaw      ★ Pin vise (1 mm)      ★ Touchup paint (black)

#### Battery removal

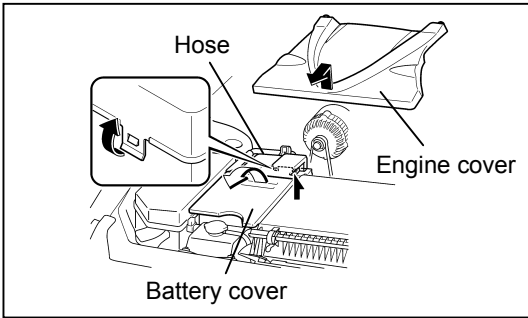

1. Make sure that the headlights and the air conditioner are turned off. Then remove the engine cover.
2. Remove the hose from the battery cover.
3. Lift up the rear of the battery cover and remove.
4. Disconnect the negative battery cable.

#### ⚠ WARNING

- Never place the battery near an open flame. Flammable gas from the battery can be ignited resulting in explosion.

#### ⚠ WARNING

<p>When connecting/disconnecting connectors, grasp the connectors, not the wires. Otherwise a fire or other accident may occur due to an open circuit or poor contact.</p>	<p>Do not apply excessive force to the wiring harness. Otherwise a fire, electrical shock, or other accident may occur due to an open or short circuit.</p>

#### ⚠ CAUTION

<p>Be sure to cover the vehicle body with protectors or mats when removing/installing parts. Otherwise, the vehicle may be scratched or become dirty.</p>	<p>Use the most appropriate (size, use) tool for each task. Otherwise the parts may be damaged.</p>	<p>Place the removed parts and the parts in the kit on a protective sheet to prevent scratches.</p>

#### ⚠ CAUTION

- Refer to the Workshop Manual for removal and installation of vehicle parts. Not following the procedures for removal/installation in the Workshop Manual could result in an accident or vehicle malfunction.
- Always perform the installation work with two people or more.

## 4 FOG LAMP BRACKET INSTALLATION

### Preparation before installation

#### ⚠ CAUTION

- When handling the front bumper face, and especially when performing work on the backside, be very careful not to injure yourself with the edges of the mesh, brackets, and other parts.

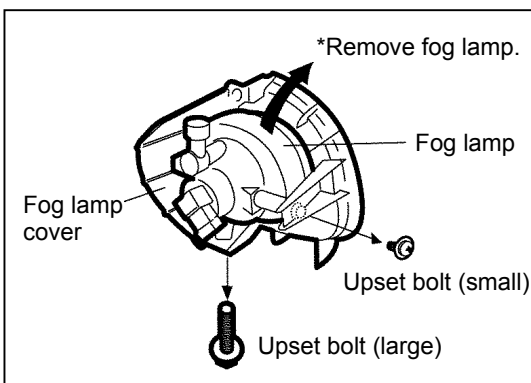
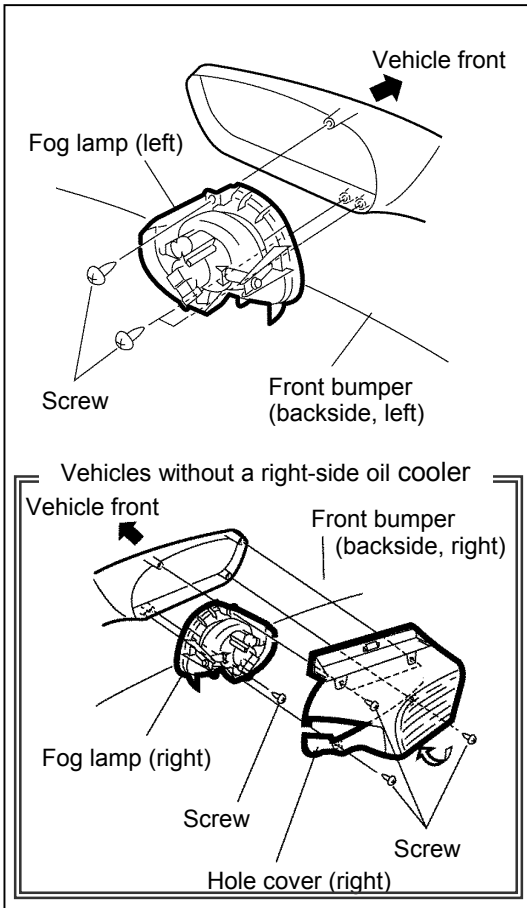

#### NOTE

- When the front bumper face has already been installed and the fog lamps are newly installed, remove the front bumper face in the reverse order of installation referring to the installation and user's instructions accompanying the front bumper face.
- The figures in these instructions are for vehicles with oil coolers installed on both the left and right sides. The figure shows the left side, however, perform the same procedure for the right side. For vehicles without an oil cooler installed on the right side, refer to the figures with a double outline when performing work.

1. Remove the right and left mud guards, and the bumper.
2. Remove the right and left fog lamp. (Remove the screws (3).)

< Vehicles without a right-side oil cooler >

1. Remove the hole cover. (Remove the screws (3).)
2. Remove the fog lamp. (Remove the screw (1).)

3. Remove the small upset bolt (1) and the large upset bolt (1) securing the fog lamp, then remove the fog lamp from the fog lamp cover.

#### ⚠ CAUTION

- Be sure not to lose the small upset bolt (1) and the large upset bolt (1) removed from the fog lamp, as they will be reused.

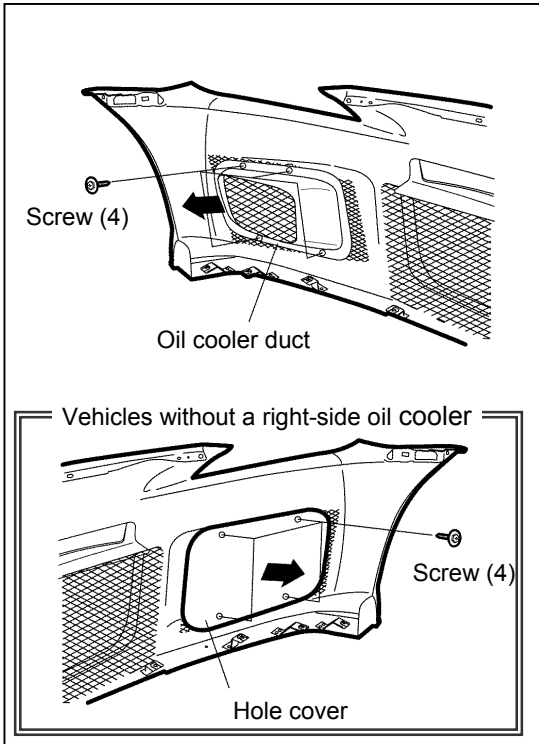

### Oil cooler duct and hole cover removal

1. Remove the oil cooler duct on the left side of the front bumper face backside and the hole cover on the right side.

< Vehicles without a right-side oil cooler >

1. Remove the hole cover. (Remove the screws (4).)

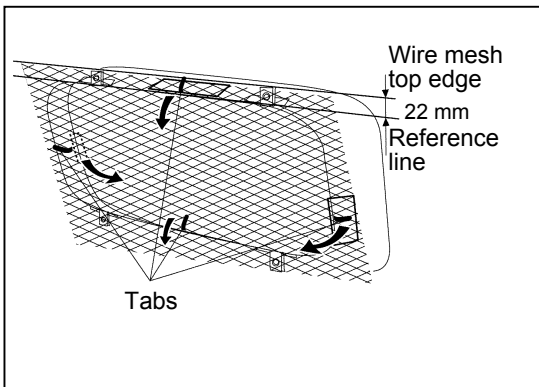

### Wire mesh installation position marking

1. Fold back the tabs of the brackets on the front bumper face and detach the wire mesh on each side.
2. Reposition the wire mesh so that the top edge is 22 mm above and parallel to the reference line shown in the figure (front bumper face backside, top edge of side opening) and secure the wire mesh.

#### ⚠ CAUTION

- Position the wire mesh so that its top edge is 22 mm above and parallel to the reference line. Make sure the mesh is even on both sides.

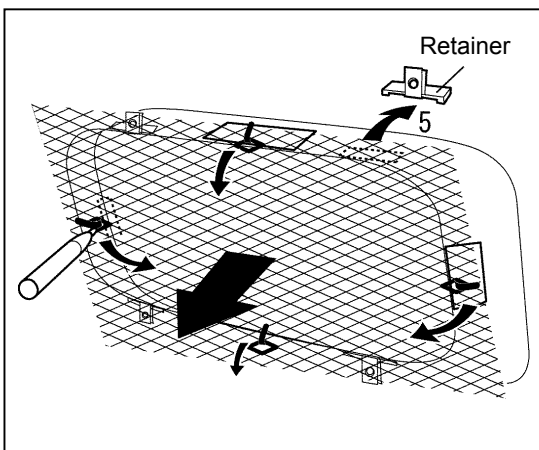

3. Using a oil-based pen, mark the positions where the wire mesh was newly secured with the brackets. Then detach the wire mesh again.
4. Remove the retainer attached to the front bumper face as shown in the figure. (The figure shows the left side, however, perform the same procedure for the right side.)

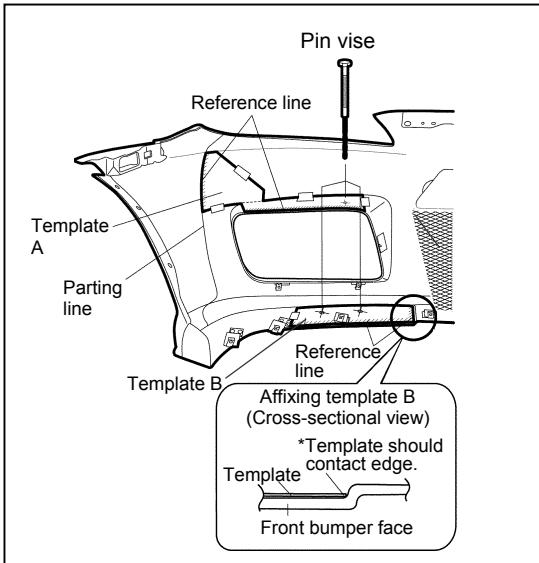

## Hole drilling

1. Cut out templates A and B.
2. Affix the templates with masking tape as shown in the figure.
3. Drill holes in the hole positions printed on the templates with a pin vise (1 mm).
4. Remove the templates after drilling.

### ⚠ CAUTION

- Be careful when handling the pin vise as it can cause injury.
- When drilling with a pin vise, be careful not to apply too much force. Otherwise the front bumper face may be damaged.

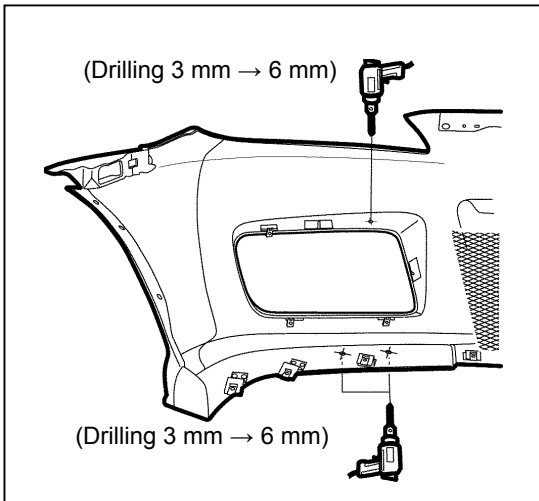

5. Using a 3-mm drill bit, drill pilot holes in the positions drilled with a pin vise from the directions shown in the figure.
6. Using a 6-mm drill bit, enlarge the pilot holes from the same directions.
7. Remove burrs around the drilled holes with a round file.

### ⚠ WARNING

- Be careful when using the drill. If the drill is not used correctly, it could result in serious injuries.

### ⚠ CAUTION

- Be sure to remove burrs around the drilled holes with a round file.

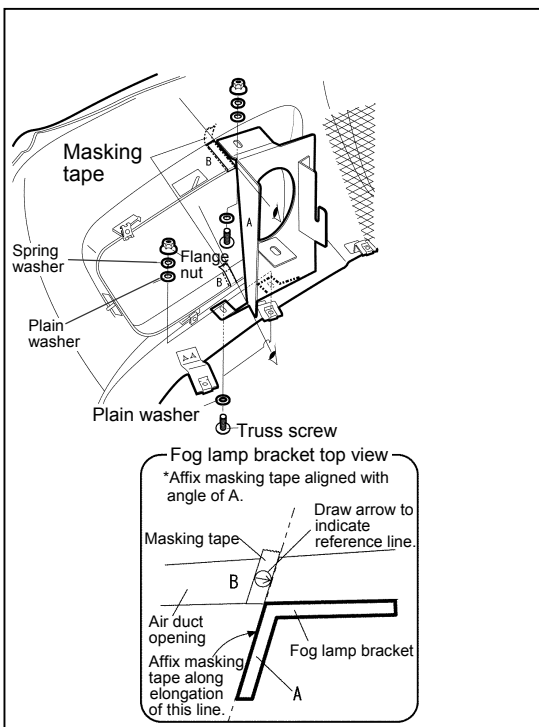

## Fog lamp installation position marking

1. Align the fog lamp bracket with the holes drilled in step 7 and temporarily secure it with the M5x15 truss screws, M5 plain washers, M5 spring washers, and M5 flange nuts.
2. Affix masking tape aligned with the angle of the fog lamp bracket as shown in the figure. Affix masking tape to the two locations, top and bottom. Affix masking tape to the top part (rear side of the front bumper) aligned with angle of A.
3. Remove the fog lamp bracket with the masking tape still affixed.

Reference masking tape

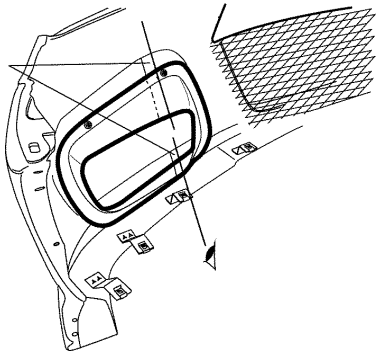

Oil cooler duct

\*Draw arrows on masking tape to indicate reference line.

### Oil cooler duct and hole cover cutting

1. Temporarily secure the oil cooler duct.
2. Affix masking tape to the inside of the oil cooler duct (top and bottom) so that it forms a straight line aligned with the other masking tape.
3. Draw arrows on masking tape to indicate reference line.
4. Remove the oil cooler duct again.  
\*Do not remove the reference masking tape.

Vehicles without a right-side oil cooler

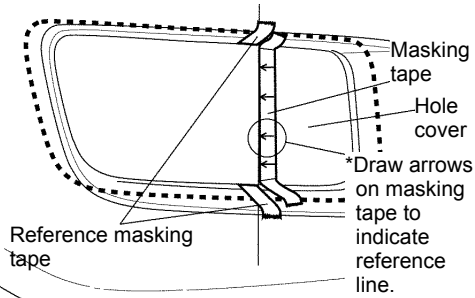

< Vehicles without a right-side oil cooler >

1. Temporarily secure the hole cover.
2. Affix masking tape to the hole cover from the front side of the front bumper face as shown in the figure.
3. Draw arrows on masking tape to indicate the reference line.
4. Remove the hole cover again.  
\*Do not remove the reference masking tape.

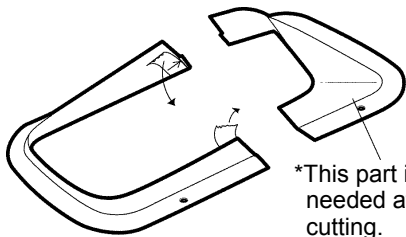

\*This part is not needed after cutting.

5. Using a hacksaw, cut the oil cooler duct and the hole cover along the masking tape affixed for reference.
6. Remove burrs.
7. Remove the reference masking tape.

#### ⚠ WARNING

- Be careful when using the drill. If the drill is not used correctly, it could result in serious injuries.

#### ⚠ CAUTION

- Be sure to remove burrs with a round file after cutting.
- Be sure to cut the parts along the reference masking tape.

\*This part is not needed after cutting.

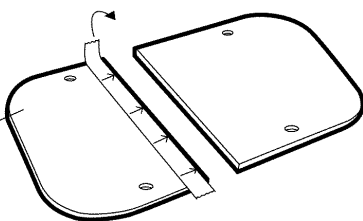

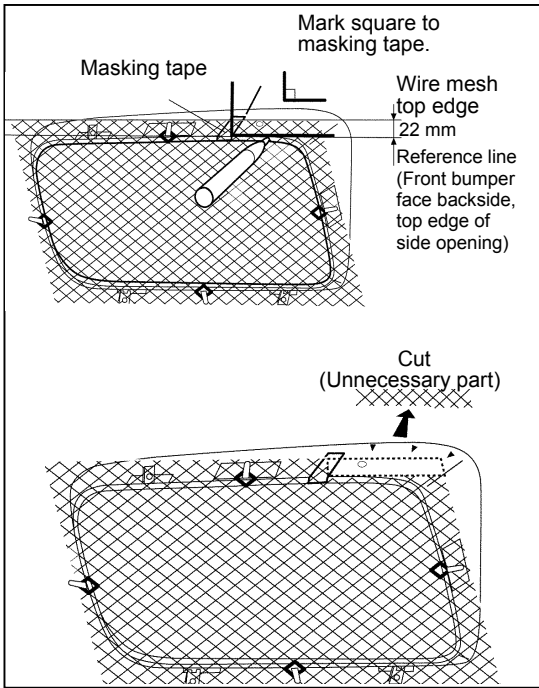

## Wire mesh cutting

1. Reattach the wire mesh on each side aligned with the positions marked.
2. Mark as shown in the figure with a white or silver oil-based pen.
3. Cut the wire mesh along the marking line with a nipper.

### ⚠ CAUTION

- Attach the wire mesh so that its top edge is 22 mm above and parallel to the reference line. If the wire mesh is not attached as specified, the fog lamp will not be installed properly. Make sure the wire mesh is even on both sides.
- After cutting the wire mesh, be careful not to cut yourself with the cut surface.

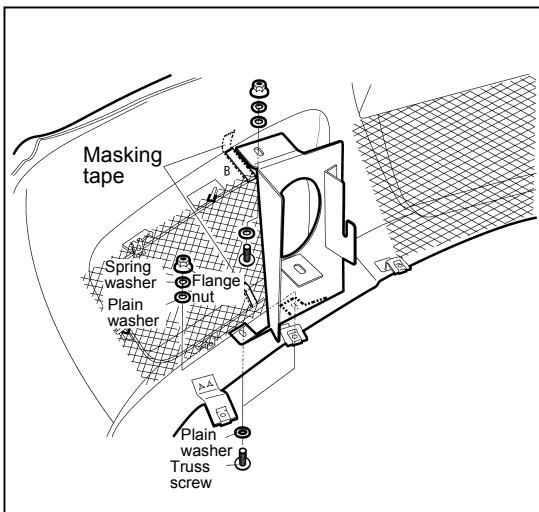

4. Temporarily secure the fog lamp bracket with the M5x15 truss screws, M5 plain washers, M5 spring washers, and M5 flange nuts.

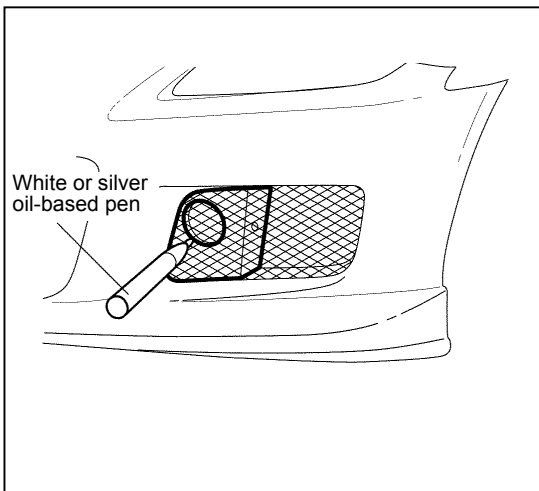

5. Trace the outline of the oval hole in the fog lamp bracket with a white or silver oil-based pen.
6. Remove the fog lamp bracket and the wire mesh in the reverse order of installation.



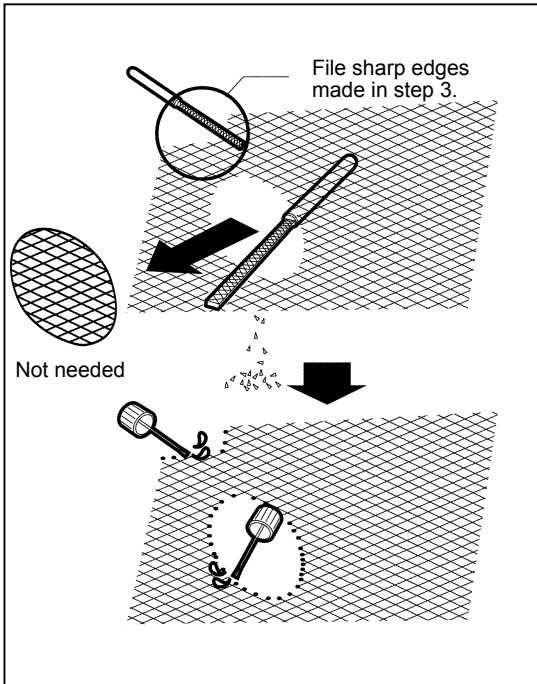

7. With a nipper, cut the wire mesh 1-2 mm outside the oval line marked with an oil-based pen.
8. File sharp edges of the cut surface.
9. Apply black touchup paint to the cut surface for rust prevention.

#### ⚠ CAUTION

- After cutting the wire mesh, be careful not to cut yourself with the cut surface.
- After cutting the wire mesh, be sure to remove burrs with a round file (until the cut surface is dull to the touch).
- Be sure to apply touchup paint to the cut surface for rust prevention.
- When filing, be careful not to apply too much force. Otherwise the wire mesh may be warped.

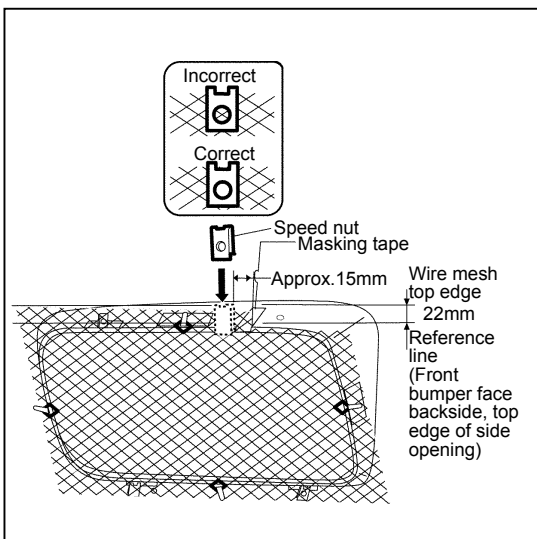

#### Speed nut installation

1. Attach the wire mesh aligning with the bracket tab to marking position.
2. Install the speed nut 15 mm to the outside of where the wire mesh was cut (so the hole isn't blocked by the mesh).
3. Remove the masking tape.

#### ⚠ CAUTION

- Attach the wire mesh so that its top edge is 22 mm above and parallel to the reference line. If the wire mesh is not attached as specified, the fog lamp will not be installed properly. Make sure the wire mesh is even on both sides.

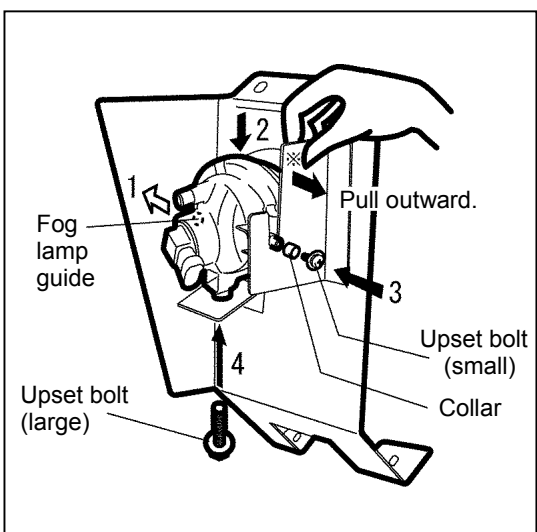

#### Fog lamp installation

1. Temporarily install the fog lamp to the fog lamp bracket as shown in the figure.
  - (1) Insert the guide of the fog lamp into the hole in the fog lamp bracket.
  - (2) While pulling the part marked with an asterisk outward, install the fog lamp to the fog lamp bracket.
  - (3) Install the collar and the small upset bolt in the order indicated in the figure.
  - (4) Install the large upset bolt.

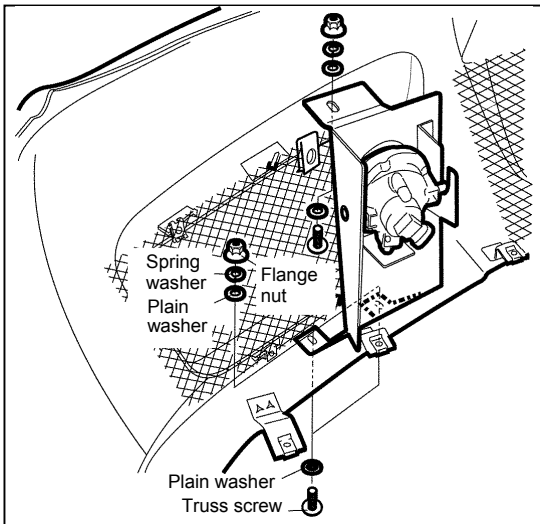

### Fog lamp bracket assembly installation

1. Install the fog lamp bracket to the front bumper face with the M5x15 truss screws, M5 plain washers, M5 spring washers, and M5 flange nuts. Secure the fog lamp bracket so that it holds down the wire mesh.

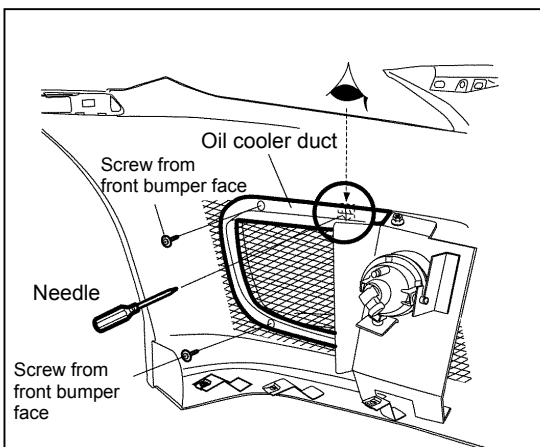

### Oil cooler duct and hole cover hole drilling

1. Install the oil cooler duct with the screws accompanying the front bumper face.
2. Locking from above, check the positions of the holes in the speed nuts and mark the hole positions on the backside of the oil cooler duct and the hole cover using a needle.
3. Remove the oil cooler duct.

< Vehicles without a right-side oil cooler >

1. Install the hole cover with the screws from the front bumper face.
2. Locking from above, check the positions of the holes in the speed nuts and mark the hole positions on the backside of the hole cover and the hole cover using a needle.
3. Remove the hole cover.

#### ⚠ CAUTION

- Needles and other sharp objects can cause injury. Be careful when handling needles and other sharp objects.
- When marking, be sure to check the position of the hole in the speed nut from the top.

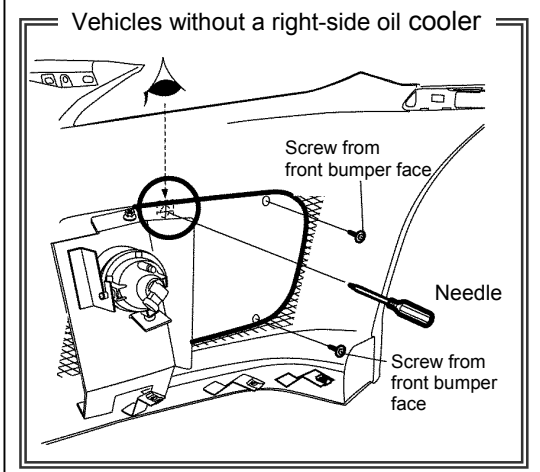

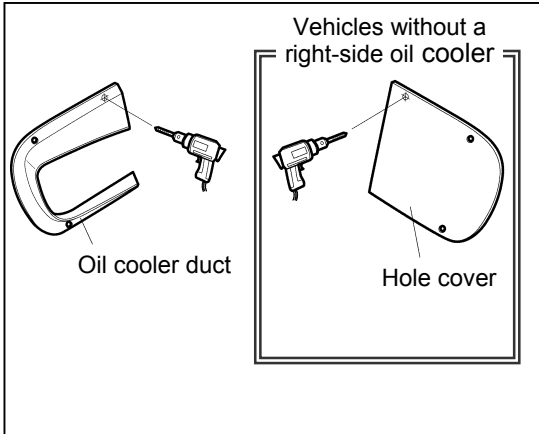

4. Drill 3-mm pilot holes in the positions marked on the oil cooler duct and the hole cover.
5. Enlarge them to 7 mm.
6. Remove burrs with a round file.

**⚠ WARNING**

- Be careful when using the drill. If the drill is not used correctly, it could result in serious injuries.

**⚠ CAUTION**

- Before marking with a needle, always first check the position of the speed nut hole looking from above.

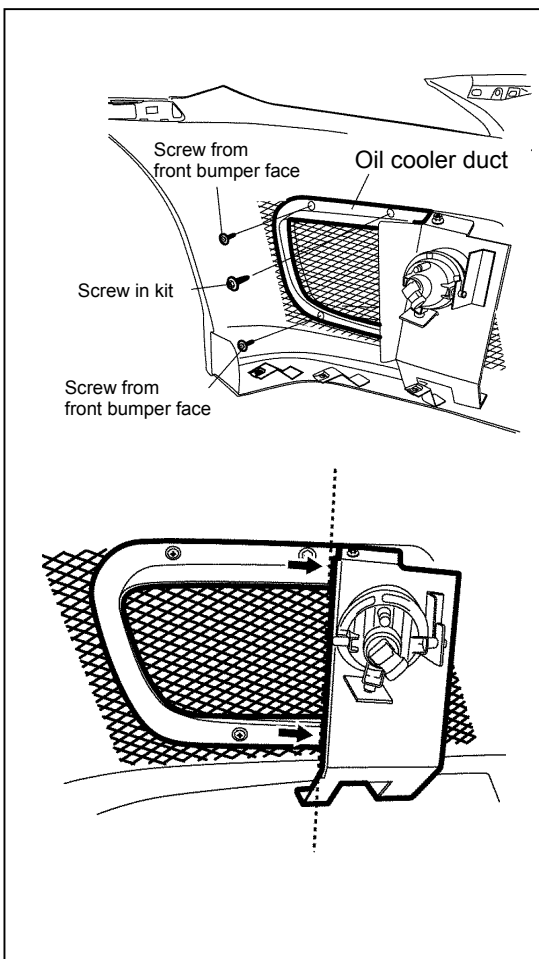

**Oil cooler duct and hole cover installation**

1. Secure the oil cooler duct with the screws from the front bumper face and the M5x20 screws in the kit.

Vehicles without a right-side oil cooler

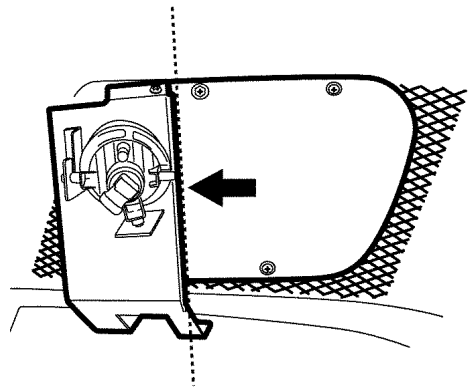
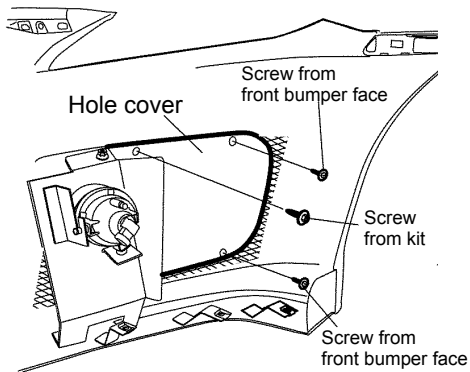

< Vehicles without a right-side oil cooler >

1. Secure the hole cover with the screws from the front bumper face and the M5x20 screws in the kit.

**CAUTION**

- When installing the oil cooler duct and hole cover, before securing any screws, be sure that there are no gaps between the fog lamp bracket assembly and the oil cooler duct or between the fog lamp and the hole cover.

**Vehicle parts reinstallation**

1. Reinstall the front bumper face in the reverse order of removal.  
\*Do not reinstall the mud guards in this step. (The mud guards will be installed after 6. FOG LAMP AIMING.)

## 5 OPERATION CHECK

- After verifying the harness routing, connect the negative battery cable.
- Check operation with the following procedure.

<Operation check procedure>

1. Verify that the headlights turn on when the light switch is turned to the headlight position.
2. Verify that the fog lamps turn on when the fog lamp switch is turned on.
3. Verify that the fog lamps turn off when the fog lamp switch is turned off.

Yes



The operation check is complete if there is no malfunction.



No

<If there is any malfunction, inspect the applicable area>

- Inspect the wiring harnesses for pinching.
- Inspect the connectors for poor connection.

## 6 FOG LAMP AIMING

1. Adjust the tire air pressure to the specification.
2. Position the unloaded vehicle on a flat, level surface.
3. Seat one person in the driver's seat.
4. Position the vehicle straight ahead and perpendicular to a white screen
5. Set the fog lamps 3 m {9.8 ft} from the white screen.
6. Place an object in front of the fog lamp not being adjusted to block its light beam.
7. Start the engine so that the battery remains charged.
8. Turn the fog lamps on.
9. Loosen the screw, move the fog lamp in the direction of the arrows, and adjust the fog lamp beam to the position shown in the figure.
10. Install the mud guards.

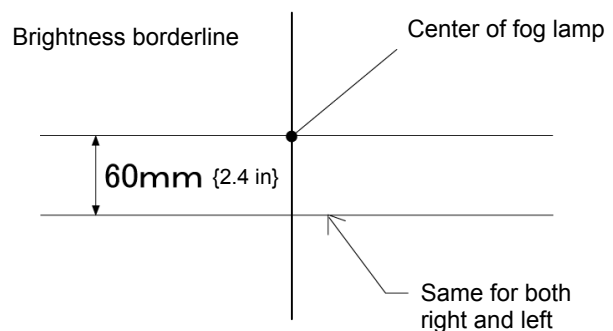
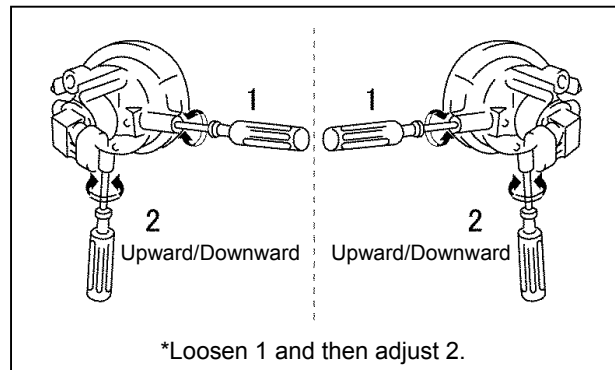
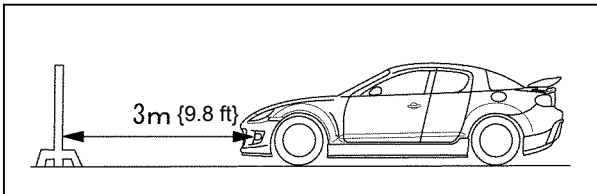

## 7 CHECK AFTER INSTALLATION

If there is no malfunction at "5. OPERATION CHECK", perform the following procedure.

1. Temporarily disconnect the negative battery cable.
2. Reconnect the negative battery cable.

### CAUTION

- When the battery is disconnected, the DSC indicator light will no longer operate. (At this time, the DSC OFF indicator light flashes and the TCS/DSC operation indicator light illuminates.)

Perform the following procedure to enable DSC operation.

1. Turn the ignition switch to the ON position.
2. Turn the steering wheel fully right and then fully left.
3. Verify that the DSC OFF indicator light goes out.
4. Turn the ignition switch off and once again to the ON position.
5. Verify that the TCS/DSC operation indicator light goes out.

If the TCS/DSC operation indicator light and the DSC OFF indicator light do not go out even after the ignition switch is turned to the ON position, contact an Authorized Mazda Dealer.

### CAUTION

- When the battery is disconnected, the power window will no longer fully open/close automatically.

Perform the following procedure to restore the function.

1. Turn the ignition switch to the ON position.
2. Press the switch to fully open the window.
3. Pull up the switch to fully close the window and continue to pull it up for about two seconds.

- Install the battery cover, hose, and engine cover in the reverse order of removal.

### CAUTION

- After attaching the engine cover, check that it is securely fixed.

### CAUTION

- Make sure that the vehicle parts are clean before reinstalling. Clean any dirty parts.

## 8 FOG LAMP BULB REPLACEMENT

1. Disconnect the battery negative terminal.
2. Remove the mud guards screw and slightly bent back the mud guard.
3. Disconnect the fog lamp connector.
4. Remove the fog lamp as shown in the figure.
5. Install the fog lamp in the reverse order of removal.

### WARNING

- If a non-specified fog lamp bulb is used, it might cause a fire. Make sure to use only the specified fog lamp bulb.

**⚠ CAUTION**

- Consult your dealer for fog lamp bracket assembly replacement.
- Use fog lamp bulb no. 90703 7550 (H11 12V 55W)
- When replacing a fog lamp bulb, always hold by the flange and do not touch the glass part of the fog lamp bulb. Otherwise, bulb life may be decreased.
- Make sure there is no oil or grease on the bulb. Oil or grease adhering to the bulb decreases bulb life.

